

**In this unit you will:**

- revise levers and linkages
- identify different types of gear systems
- learn about the concept of mechanical advantage

**Introduction**

Machines help to make our lives and work easier. Machines were invented to help us with tasks that we must complete. In this unit, you are going to find out how various types of machines work. We will focus on the following types of machines:

- levers and linked levers
- gear systems.

**Systems diagram**

Machines do work to achieve a particular purpose. A machine is a mechanical system which can be represented by a systems diagram. All systems have **input\***, **process\*** and **output\***.

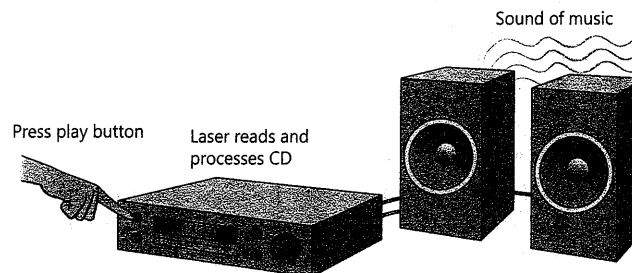


Figure 9.1 The input, process and output of a CD player

**Word Box**

**input:** the force or information entered into a system  
**process:** the part of a system that combines resources to produce an output that is in response to input  
**output:** the actual result obtained from a system

**Levers**

In Grade 7, you learnt that a lever is a mechanism which is part of a simple machine. Levers in machines make our work easier by:

- enabling us to pull or push over bigger distances, and
- to move a large load with small effort.

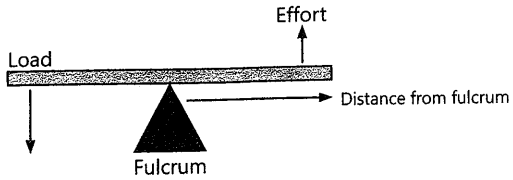


Figure 9.2 Parts of a lever

**fulcrum:** a pivot or the point around which a lever or bar turns  
**prize:** to move or force something to open

The **further** the effort is away from the fulcrum, the **easier** it is for a lever to move a load. We can therefore say that in general, long levers are more useful.

Very often, levers help us to turn a small force (input) into a much larger force (output). Think about opening a tin of paint. You cannot do it with your fingers alone. You must use a lever to help you. When you exert a small force on one end of the lever, you are creating a much larger force at the other end. This larger force prizes\* the lid open.

What is common with a garden fork, a pair of scissors and the door handle that opens your classroom door? They are all levers. Although levers have been around for thousands of years, they are still found in some very important modern machines.

Levers give us advantage in the following ways:

- They are used to move heavy loads.
- They can be used to change the direction of motion.
- They allow for change of force for gaining distance.
- They can change distance for gaining force.

**How does a lever work?**

The amount of work done is determined by the force applied (effort) multiplied by the distance from the fulcrum. The lever allows less effort to be used to move an object over a greater distance. For instance, to use a lever to lift a certain unit of weight with an effort of half a unit, the distance from the fulcrum of the spot where force is applied must be twice the distance between the weight and the fulcrum.

**Mechanical advantage**

Mechanical advantage is a concept that describes how much easier mechanisms or machines can make a particular task. For example, to reduce (halve) the effort of lifting a weight resting one metre from the fulcrum, we would need to apply force two metres from the other side of the fulcrum. The amount of work done is always the same and independent of the dimensions of the lever (in an ideal lever). The lever only allows us to trade effort for distance.

**Classes of levers**

There are three classes of levers – first-class levers, second-class levers and third-class levers. Levers are classified according to:

- variations in the location of the fulcrum, and
- differences in the input and output forces.

**Single first-class levers**

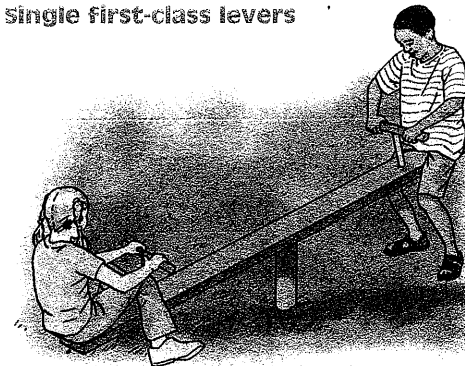


Figure 9.3 A see-saw is a first-class lever



Item	Number of levers
See-saw 	One first-class lever
Claw hammer used to remove nails 	One first-class lever

Figure 9.4 Examples of single first-class levers

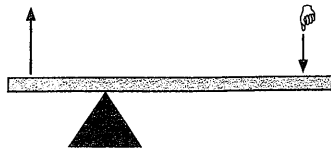


Figure 9.5 A diagram showing a first-class lever

Mechanical advantage depends on the position of the fulcrum.

A first-class lever is a lever in which the fulcrum is located between the input force and the output force. A force is applied (by pulling or pushing) to a section of the bar, which causes the lever to swing about the fulcrum, changing the direction of the force and overcoming the resistance force on the opposite side. The fulcrum is the centre of the lever on which the bar (as in a see-saw) lays upon. This supports the effort arm and the load.

**Linked first-class levers**

Linked levers are levers that are connected to each other.

Item	Number of levers
Scissors	Two first-class levers
Secateurs	Two first-class levers

Figure 9.6 Examples of linked first-class levers

**ACTIVITY 1 LINKED FIRST-CLASS LEVERS AND MECHANICAL ADVANTAGE**

Carefully study the diagrams of the scissors and secateurs shown above and then answer the questions below.

1. How many levers are used in each tool?
2. If the paper scissors had an equal length blade and handle, how much mechanical advantage would be obtained? Explain your answer.

3. Look at the two pairs of secateurs in Figure 9.6. One pair of secateurs has long handles and strong blades. The other pair of secateurs has short handles and strong blades. How much mechanical advantage will you obtain if you use each pair to prune trees in your garden?

**Single second-class levers**

In a second-class lever, the input is located at the end of the bar, the output is located in the centre of (or along) the bar, and the fulcrum is located at the end of the bar opposite to the input. Single second-class levers always give some mechanical advantage.

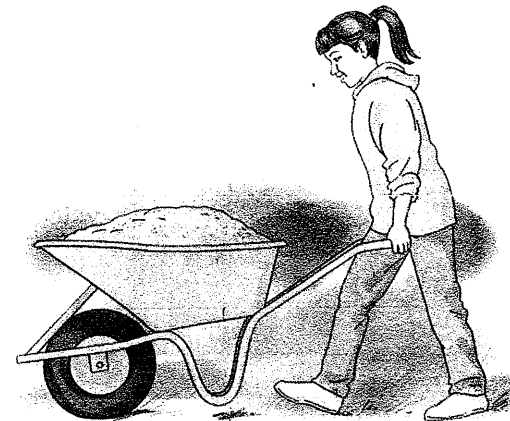


Figure 9.7 A wheelbarrow is a second-class lever

Item	Number of levers
Bottle opener	One second-class lever
Wheelbarrow	One second-class lever

Figure 9.8 Examples of single second-class levers

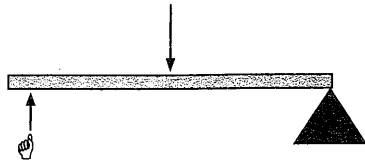


Figure 9.9 A diagram showing a second-class lever

Linked second-class levers

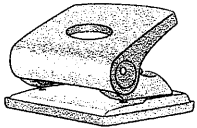
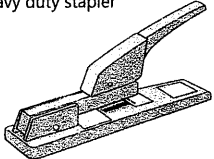
Item	Number of levers
Office punch 	Two second-class levers
Heavy duty stapler 	Two second-class levers

Figure 9.10 Examples of linked second-class levers

ACTIVITY 2 LINKED SECOND-CLASS LEVERS AND MECHANICAL ADVANTAGE

Carefully study the diagrams of the office punch and heavy duty stapler shown above and answer the questions below.

1. How many levers are used in each tool?
2. Will the office punch give mechanical advantage?
3. Do you think that the mechanical advantage gained from the heavy duty stapler is greater than one or less than one? Explain your answer.

Single third-class levers

This class of levers differs from first-class and second-class levers in that the effort (input) is greater than the load (output). This lever never gives any mechanical advantage. You will also notice that the effort (input) has to move a shorter distance than the load (output). Therefore, the third-class lever is still useful in making certain tasks easier to complete. Effort is applied in the centre of the lever, and this does work (raising the load). The output is on the opposite end of the input and this allows you to gain a lot of movement.

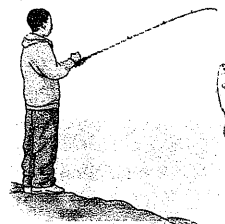
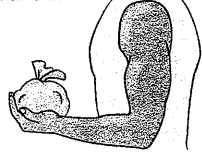
Item	Number of levers
Fishing rod 	One third-class lever
Human arm 	One third-class lever

Figure 9.11 Examples of single third-class levers

In the diagram below, identify the position of the fulcrum, effort and load.

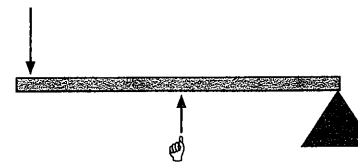


Figure 9.12 Diagram showing a third-class lever




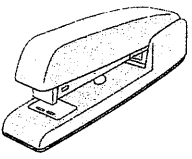
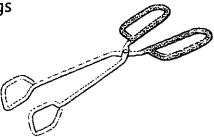
Item	Number of levers
Tweezers 	Two third-class levers
Light duty office stapler 	Two third-class levers
Tongs 	Two third-class levers

Figure 9.13 Examples of third-class levers

**ACTIVITY 3 LINKED THIRD-CLASS LEVERS AND MECHANICAL ADVANTAGE**

Carefully study the diagrams of the tweezers, light duty office stapler and tongs shown in Figure 9.13 and answer the questions below.

- How many levers are used in each case?
- Will the tweezers give any mechanical advantage?
- Do you think that the mechanical advantage gained from the light duty office stapler is greater than one or less than one? Explain your answer.

**Gear systems**

You learned about gears in Unit 4. Let us find out more about them. A gear is a **wheel** that has evenly spaced **teeth** around its edge. In mechanical systems, a gear can **transfer movement (force)** to another gear. Gears can **change the speed (velocity)** at which a driven gear rotates. Gears can also **change the direction** in which the driven gear rotates. In order for this to happen, at least two gear wheels are needed. One gear wheel on its own will not work. A **gear train** is formed when two or more gears work together. The shape of the teeth differs in each system of gear wheels and depends on the type of job that must be done.

**Spur gears**

The most common type of gears is the spur gears. The two shafts that the gears are attached to are parallel to each other. These gears also have straight teeth.

Figure 9.14 below shows two spur gears of unequal size. When one gear meshes with the other, the gears will turn in opposite directions (**counter rotation**).

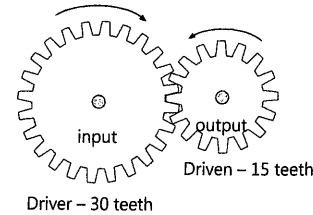


Figure 9.14 Diagram showing gears counter rotating

The driver gear transfers the input movement (driving force) to the driven gear (output movement). If the larger driver gear has 30 teeth and transfers a force to a smaller gear with 15 teeth, then the force will be halved (**decrease**) whilst the speed of the original rotation will be doubled (**speed advantage / multiplication**). We can say that the **gear ratio** is 2:1 (since the end rotational speed is doubled) and that the **mechanical advantage** is 0.5 (less than one) since the force is halved. The **velocity ratio** is 1:2.

$$\text{Mechanical advantage} = \frac{\text{driven}}{\text{driver}} = \frac{15}{30} = \frac{1}{2}$$

Shown in Figure 9.16 is the common method used to graphically indicate the spur gears which is called a **systems diagram**.

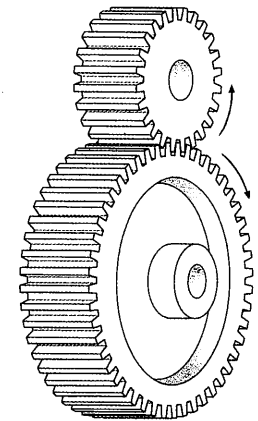


Figure 9.15 Spur gears

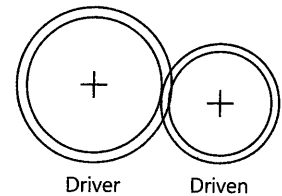


Figure 9.16 Graphical representation of spur gears

**Gear ratio**

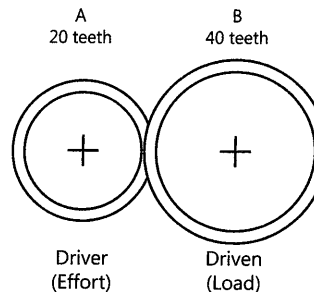


Figure 9.17 Small driver gear and large driven gear

When the smaller Gear A (driver gear) is used to drive the larger Gear B (driven gear) the larger gear rotates slower than the small gear. Why does this happen?

The driver gear has to travel through 20 teeth to complete one revolution whilst the driven gear travels through 40 teeth to complete one revolution. Since the driven gear takes longer (more teeth) to complete one revolution, it therefore travels at a slower speed. The **gear ratio** in this case is 1:2. This is because the **end rotational speed is halved**.

Look at the diagram on page 103. When the driven gear has more teeth than the driver gear, a **mechanical advantage** of more than one will be obtained.

$$\begin{aligned} \text{Mechanical advantage} &= \frac{\text{driven}}{\text{driver}} \\ &= \frac{40}{20} \\ &= 2 \end{aligned}$$

When the smaller driver transfers a force to a larger gear, then the force will be doubled (this is known as **force multiplication**) whilst the speed of the original rotation will be halved (decrease).

The force ratio is the ratio of the number of turns of the driven gear with that of the driver gear.

$$\begin{aligned} \text{Force ratio} &= \frac{\text{Number of teeth of the driver gear (input)}}{\text{Number of teeth of the driven gear (output)}} \\ &= \frac{20}{40} = \frac{1}{2} \end{aligned}$$

The force ratio will therefore be 1:2.

This means that for every one rotation of the driven gear, the driver gear must rotate twice.

### idler gears

Gear systems have different purposes. Spur gears are arranged to reverse the direction of rotation. To make sure that the direction of rotation is maintained, a third gear must be placed between the two gears. The driven gear and the driver gear rotate in the same direction (**synchronised\* rotation**). This third gear is called an idler gear.

The idler gear is smaller than the driver and driven gears. It rotates faster than the other two gears. The idler gear is usually made of a harder material because it must wear down quickly. The idler gear will only maintain the original direction of movement and not change the speed of the gears.

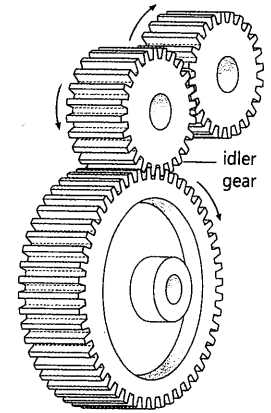


Figure 9.18 Spur gears with an idler gear

### Bevel gears

Bevel gears are used to change the plane of motion, one turns vertically and the other turns horizontally. The shafts attached to the bevel gears, form a 90° angle. Bevel gears are most often used when two parallel gears are driven by the same motor. The teeth of the bevel gear are at an angle.

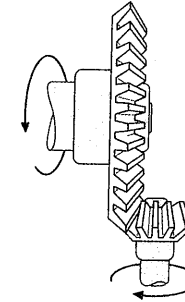


Figure 9.19 Bevel gears change the plane of motion

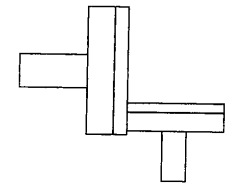


Figure 9.20 Graphic symbol for bevel gears

## ACTIVITY 4 GEAR SYSTEMS

In Figure 9.21, the movement is changed from horizontal to vertical. Identify the input gear and the output gear and indicate the direction of movement of each gear.

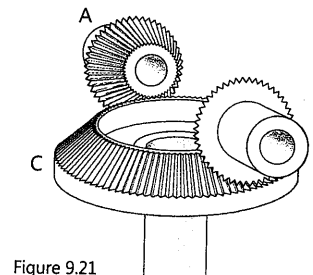


Figure 9.21

**synchronised:** occur at the same time

### Summary

- A machine is a mechanical system made up of **input, process** and **output**.
- **Levers** make work easier by enabling us to **pull or push over bigger distances** and to **move a load with smaller effort**.
- All levers have a **load, effort** and **fulcrum**.
- A lever allows less effort to be used to move an object over a

- greater distance.
- **Mechanical advantage** (MA) describes how much easier mechanisms or machines can make a particular task.
- There are three classes of levers that are classified according to the **position of the fulcrum** and differences in input and output forces.
- Mechanical advantage depends on the position of the fulcrum.
- **Linked levers** are levers that are **connected** to each other.
- A **gear** system allows for transfer of **movement**, change of **speed** or a change in **direction**.
- **Spur gears** rotate in **opposite** directions.
- A **gear ratio** is the ratio of the number of teeth of the input gear (driver) to that of the output gear (driven).
- The **force ratio** is the ratio of the number of turns of the driven gear with that of the driver gear.
- An **idler gear** is used to maintain the direction of rotation of the driven gear to the driver gear.
- **Bevel gears** change the plane of motion (most often at 90°).

#### Questions

1. What do you understand by the terms "input", "process" and "output"?
2. How do levers make our work easier?
3. List four ways in which levers give us advantage.
4. Explain what you understand by the concept "mechanical advantage".
5. State the three classes of levers and give one example of each.
6. Draw line diagrams to show the three classes of levers mentioned in Question 5 above.
7. What is the difference between single levers and linked levers?
8. State three changes that a gear system helps us achieve.
9. What is a gear train?
10. In a system of unequal spur gears that has a driver gear with 60 teeth and a driven gear of 30 teeth, is the mechanical advantage obtained greater than one or less than one?
11. When the driver gear has 60 teeth and the driven gear has 20 teeth, is the mechanical advantage less than one or greater than one?
12. When will a gear system have a mechanical advantage equal to one?
13. What should you do to achieve the same direction of rotation in two spur gears?
14. Why should the idler gear be manufactured from a harder material than other gears?
15. What type of gear would you use to change movement from horizontal to vertical?

#### In this unit you will:

- calculate mechanical advantage for levers
- calculate mechanical advantage for gears

#### What is mechanical advantage?

When a machine takes a small input force and increases the size of the output force, a mechanical advantage has been produced.

#### Levers

In Unit 9 you revised the different types of levers.

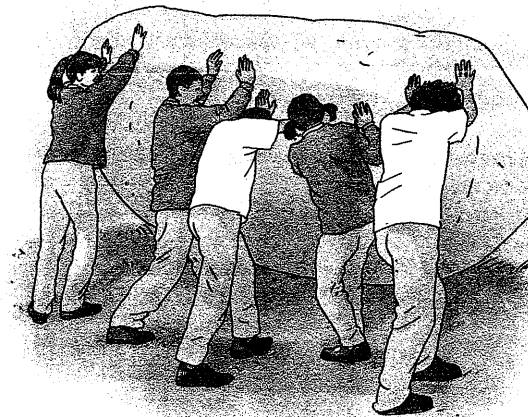


Figure 10.1 Using a lever would make light work of moving this rock

A rock prevents you and your friends from playing soccer on an open field near your house. The rock weighs 12 newtons (N). If you use a lever to move the rock, the effort you will put in is 2N. You can calculate the mechanical advantage obtained by using the lever.

To calculate mechanical advantage, you need to divide the load by the effort.

$$\begin{aligned}
 MA &= \text{load/effort} \\
 &= 12\text{N} \div 2\text{N} \text{ (The units cancel.)} \\
 &= 6 \text{ or } 6:1 \text{ (This is a ratio and has no units.)}
 \end{aligned}$$

This tells you that you used six times less effort to move the rock using a lever than the effort you would need without the lever.

### Mechanical advantage from a first-class lever

Remember that in order to determine the mechanical advantage we use the formula:

$$MA = \text{load/effort}$$

Figure 10.2 below shows a first-class lever with a load that is lifted by an effort. In each case the distance from the fulcrum is indicated.

The load has a weight of 300 newtons (N). The distance of the load from the fulcrum is 30 metres (m). The effort is 60 metres away from the fulcrum.

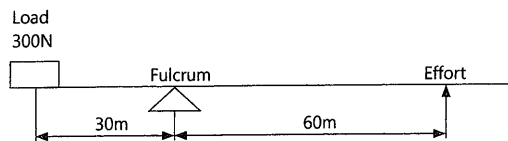


Figure 10.2 Diagram showing a first-class lever

To find the mechanical advantage, we must first find the effort required to lift the load.

We use the formula:

$$\text{load arm} \times \text{load force} = \text{effort arm} \times \text{effort force}$$

Using the values given we get:  $30\text{m} \times 300\text{N} = 60\text{m} \times \text{effort force}$

$$\begin{aligned} \text{Therefore: Effort force} &= \frac{30}{60} \times 300\text{N} \\ &= \frac{1}{2} \times 300\text{N} \end{aligned}$$

$$\text{Effort force} = 150\text{N}$$

To determine the mechanical advantage (MA) =  $\frac{\text{load}}{\text{effort}}$

$$= \frac{300\text{N}}{150\text{N}}$$

$$(MA) = 2$$

### Mechanical advantage from a second-class lever

Study the diagram of the wheelbarrow shown in Figure 10.3 below. Can you identify the fulcrum, load and effort? The load is 0.5m away from the fulcrum while the effort is 1.5m away from the fulcrum. Can you calculate the mechanical advantage?

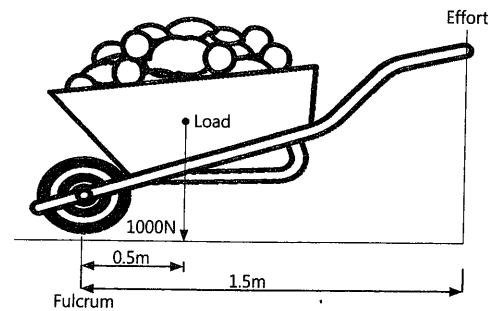


Figure 10.3 Wheelbarrow

To find the mechanical advantage, we must first find the effort required to lift the wheelbarrow.

We use the formula:

$$\text{load arm} \times \text{load force} = \text{effort arm} \times \text{effort force}$$

Using the values given we get:  $0.5\text{m} \times 1\,000\text{N} = 1.5\text{m} \times \text{effort force}$

$$\begin{aligned} \text{Therefore: Effort force} &= \frac{0.5}{1.5} \times 1\,000\text{N} \\ &= \frac{1}{3} \times 1\,000\text{N} \end{aligned}$$

$$\text{Effort force} = 333\text{N}$$

To determine the mechanical advantage (MA) =  $\frac{\text{load}}{\text{effort}}$

$$= \frac{1\,000\text{N}}{333\text{N}}$$

$$(MA) = 3$$

### Mechanical advantage from a third-class lever

In the third class lever, the fulcrum is at the end of the lever. The load is at the other end and the effort is in between.

An example of a this lever is your forearm. The fulcrum is your elbow, the effort is where your muscle attaches to the bone of your forearm and the load is at the end in your hand.



No mechanical advantage is obtained since the MA will always be less than one.

However, the practical application is that the force between the load moves in the same direction as the force you apply.

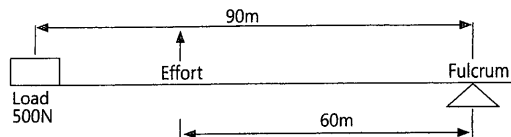


Figure 10.4 Diagram showing a third-class lever

Figure 10.4 shows a third-class lever with a load that is lifted by an effort. In each case the distance from the fulcrum is indicated.

The load is 500 newtons (N). The distance of the load from the fulcrum is 90 metres (m). The effort is 60 metres away from the fulcrum.

To find the mechanical advantage, we must first find the effort required to lift the load.

Once again we make use of the formula:

$$\text{load arm} \times \text{load force} = \text{effort arm} \times \text{effort force}$$

Using the values given we get:  $90\text{m} \times 500\text{N} = 60\text{m} \times \text{effort force}$

$$\begin{aligned} \text{Therefore: Effort force} &= \frac{90}{60} \times 500\text{N} \\ &= 1.5 \times 500\text{N} \end{aligned}$$

$$\text{Effort force} = 750\text{N}$$

To determine the mechanical advantage (MA) =  $\frac{\text{load}}{\text{effort}}$

$$= \frac{500\text{N}}{750\text{N}}$$

$$(\text{MA}) = 0.66 \text{ (less than 1)}$$

The standard unit of **mass** is the kilogram. You must therefore do all calculations using the correct units. In order to convert grams to kilograms do not forget to divide by 1 000.

The standard unit for **distance** is the metre. You must make sure that you convert millimetres to metres by dividing by 1 000.

Be careful when you work with mass. The mass must be multiplied by the force of gravity (10 N/kg) in order to convert mass to weight. The standard unit for **weight** is the newton (N).

### ACTIVITY 1 MECHANICAL ADVANTAGE CALCULATIONS FOR LEVERS

1. Study the diagram in Figure 10.5. Calculate the effort required to lift the load and then determine the mechanical advantage that the lever will give.

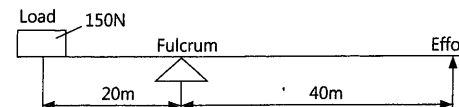


Figure 10.5

2. Calculate the mechanical advantage obtained when a wheelbarrow allows you to lift a cement and sand mixture (mortar) of a weight of 490N by using an effort of 70N.
3. Calculate the MA obtained when a lever allows you to move a rock that weighs 20N by using an effort of 4N.
4. Calculate the mechanical advantage in a third-class lever that has a load of 200N and requires an effort of 300N.
5. Study the diagram of the wheelbarrow in Figure 10.6. Calculate the effort required to lift the wheelbarrow and then determine the mechanical advantage.

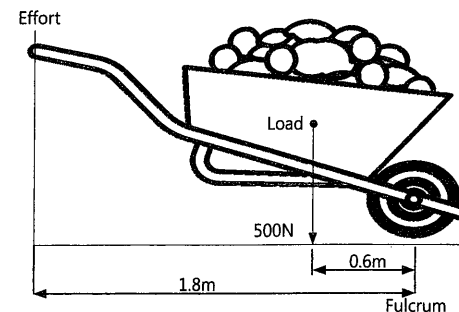


Figure 10.6

In Unit 9 you learned about the concept of mechanical advantage obtained from using gears. In order to calculate MA and different ratios in gears, we count the number of teeth on the driver and the driven gears, and apply these using the appropriate formula.

#### Calculations using tooth ratios

If a driver gear with 80 teeth, transfers force to a driven gear that has 20 teeth, this is how you calculate the MA.

$$\begin{aligned} \text{Mechanical Advantage} &= \frac{\text{Number of teeth of the driven gear (output)}}{\text{Number of teeth of the driver gear (input)}} \\ &= \frac{20}{80} \\ &= \frac{1}{4} \\ &= 0.25 \end{aligned}$$

#### Calculations using gear wheel diameters

If you have no information about the number of teeth on the gears, you can calculate MA by using the outside diameters of the two gear wheels.

If a driven gear has a diameter of 300mm and is driven by a gear wheel with a diameter of 100mm. Note that the driver gear has a diameter of 100mm.

$$\begin{aligned} \text{Mechanical Advantage} &= \frac{\text{Diameter of the driven gear}}{\text{Diameter of the driver gear}} \\ &= \frac{300}{100} \\ &= \frac{3}{1} \\ &= 3 \end{aligned}$$

#### Calculations using velocity ratios

You can also calculate mechanical advantage using velocity ratios.

Velocity ratio =

Number of teeth (driven gear) : Number of teeth (driver gear)

or = Diameter of driven gear : Diameter of driver gear

If a gear system has a calculated velocity ratio of 1:3, it means that the number of teeth (driven gear) = 1 unit while the number of teeth (driver gear) = 3 units.

These values are used to calculate MA as follows:

$$\text{Mechanical Advantage} = \frac{\text{No. of teeth (driven gear)}}{\text{No. of teeth (driver gear)}} = \frac{1}{3} = 0.333$$

#### ACTIVITY 2 CALCULATION OF MECHANICAL ADVANTAGE IN GEAR SYSTEMS

1. The velocity ratio of a gear system is 4:1. Calculate the mechanical advantage of this gear system.
2. Calculate the mechanical advantage obtained if a driver gear has 25 teeth and the driven gear has 75 teeth.
3. Calculate the mechanical advantage in a gear system that has a gear with 30 teeth that is driven by a gear with 60 teeth.
4. What mechanical advantage is obtained when both gears have an equal number of teeth?

#### Summary

- **Mechanical advantage** is produced when a machine increases the size of the output force.
- Some levers produce a mechanical advantage greater than one while others produce a mechanical advantage of less than one.
- A **first-class lever** produces a mechanical advantage greater than one.
- **Mechanical advantage = load / effort**
- When the load or effort is not known, we substitute using the formula:  
**Load arm × load force = effort arm × effort force** and then find the unknown value.
- A **second-class lever** produces a mechanical advantage greater than one.
- A **third-class lever** always produces a mechanical advantage less than one.
- When MA is equal to one, then no advantage by force multiplication is obtained.
- All calculations must be done using **SI units**. The unit for weight is newton (N) and metre (m) for distance.

To calculate the MA of a gear system, we count the number of teeth on the driver gear and the driven gear.

- **MA is the ratio** of the number of teeth of the driven gear to the number of teeth of the driver gear.
- MA can also be calculated by using the **diameters** of the gears in mesh.
- The **velocity ratio** is the ratio of the number of teeth on the driven gear to the number of teeth on the driver gear.

**Questions**

1. Define mechanical advantage.
2. What are the three classes of levers?
3. How much MA does a first-class lever produce? (**Hint:**  $<1$ ;  $=1$  or  $>1$ )
4. How much MA does a second-class lever produce?
5. What advantage does a third-class lever give even though the MA is less than one?
6. A first-class lever requires an effort of 240N to lift a load of 720N. Calculate the MA obtained.
7. Study the diagram below. What class of lever is shown? Calculate the MA that the lever will give.

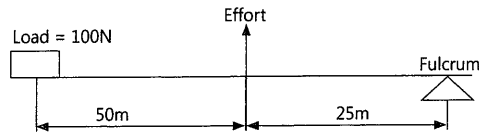


Figure 10.7

8. A third-class lever produces an MA of 0.33. If an effort of 300N is required to lift the load, calculate the size of the load.
9. Calculate the MA obtained in a gear system that has a driven gear with 60 teeth and an input gear with 15 teeth.
10. If a gear system has an MA of 4, how many teeth must the driver gear have if it is to rotate a driven gear with 120 teeth?

**In this unit you will:**

- draw gear systems
- write a design brief for a device that will give force multiplication
- write a design brief for a device that will give an increase in output velocity
- draw isometric sketches showing gear systems

**ACTIVITY 1 REPRESENT GEAR SYSTEMS GRAPHICALLY**

Use a pencil and a compass and/or a circular template\* to draw the following gear trains as shown in the diagram. Answer the questions that follow. Make sure that your gear system has the correct graphic representation.

**Word box:**  
**template:** a pattern used as a guide

**Note:** A = Driver gear  
 B = Driven gear  
 C = Idler gear

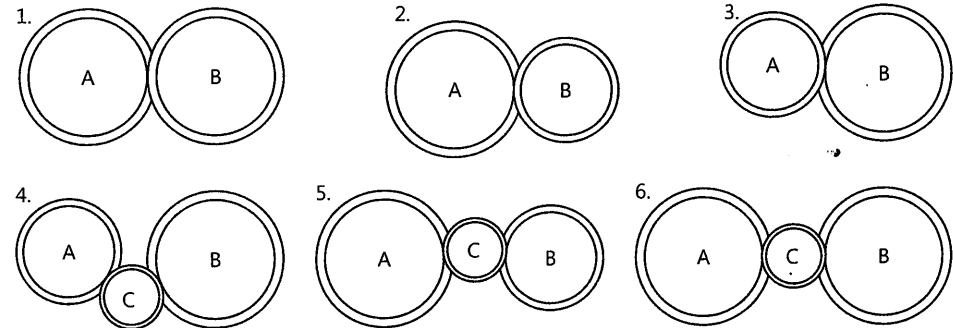


Figure 11.1

1. Which letter represents the **idler gear** in diagrams 4, 5 and 6?
2. Match the situations described below with the gear trains shown above. Write down only the number (1-6) of your answer in each case.
  - a) The driven gear rotates in the **opposite** direction (counter rotation) to the driver.

- b) The driven gear rotates in the **same** direction as the driver with the help of an idler gear.
- c) The driven gear rotates **faster** than the driver but without an idler gear.
- d) The driven gear rotates **faster** than the driver and includes an idler gear.
- e) The driven gear rotates **slower** than the driver but without an idler gear.
- f) The driven gear rotates **slower** than the driver and includes an idler gear.
- g) The driven gear rotates at the **same** speed as the driver without an idler.

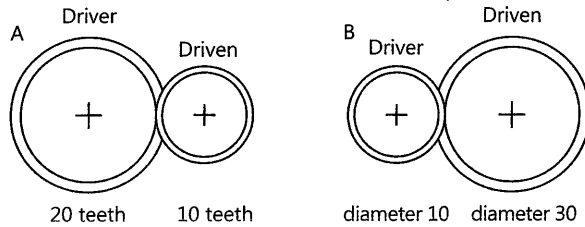


Figure 11.2

3. Study the two gear trains A and B and then answer the following:
- What is the mechanical advantage obtained in A? (**Hint:** Force is halved)
  - What is the velocity ratio in B? (**Hint:** Change in speed)
  - What is the gear ratio in A? (**Hint:** Count the number of teeth)

### Design skills

#### Design brief

Write a design brief with specifications for a device that will use a combination of gears (at least two gears) to achieve:

- a mechanical advantage with **force multiplication of three** times.
- an increase in **output velocity** (speed advantage) of **four** times.

Remember that a design brief has two parts:

- What are you going to design?
- What purpose will it achieve?

Now write your design brief for the first device (**a**) in the following format:

**What am I going to design?**

**What will it achieve?**  
(**Hint:** force change)

Consider the first specification. You are required to achieve a mechanical advantage or force multiplication of three times.

If there is force multiplication of three times, then the mechanical advantage will be three.

$$\text{Mechanical advantage} = \frac{\text{driven}}{\text{driver}} = \frac{30}{10} = 3$$

**Will the driven gear be larger or smaller than the driver gear?**

The driven gear will have three times the number of teeth of the driver gear. In other words, the driven gear must also be three times the diameter of the driver gear.

**Look carefully at the diagrams below. Which one will satisfy your specifications?**

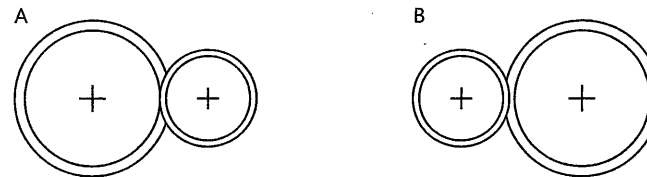


Figure 11.3

Write your own specifications for this device.

You need to write down the specifications of the two gears for the **first device**.

**Driver gear:**  
**Diameter\*:**  
**Number of teeth:**

**Driven gear:**  
**Diameter:**  
**Number of teeth:**

**Word Bank**  
**diameter:** a straight line passing from side to side through the centre of a circle

Let us look at device **B**. You need a specification of an increase in **output velocity** (speed advantage) of **four** times.



Write your design brief for the second device B in the following format:

**What am I going to design?**

**What will it achieve?**

(Hint: Speed increase)

Consider the specification. You are required to achieve an output velocity (speed advantage) of four times. If there is an increase in speed of four times, then the gear ratio will be 4:1.

If there is force multiplication, will the driven gear be larger or smaller than the driver?

The driver gear will have four times the number of teeth of the driven gear. The driver gear must also be four times the diameter of the driven gear.

Remember that you cannot get speed advantage without some loss. Since there is speed advantage of four, the mechanical advantage will be  $\frac{1}{4}$  (0.25).

$$\text{Mechanical advantage} = \frac{\text{driven}}{\text{driver}} = \frac{10}{40} = \frac{1}{4} = 0.25$$

Write your own specifications for this device.

Look carefully at the diagrams below. Which one will satisfy your specifications?

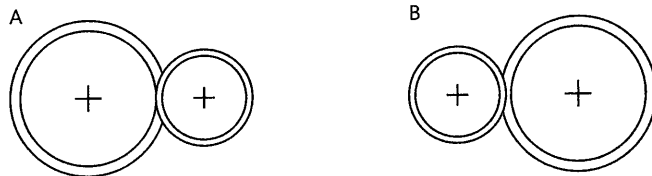


Figure 11.4

You need to write down the specifications of the two gears for the second device B.

**Driver gear:**

**Diameter:**

**Number of teeth:**

**Driven gear:**

**Diameter:**

**Number of teeth:**

### Draw

We can graphically represent the gear systems in a pictorial view.

Draw **isometric\* views** with instruments of the gear systems you designed for each device (a) and (b) above.

Remember that each gear is a **circular metal disc** out of which the gear is machined (cut). Therefore you need to draw isometric views of the circular discs that represent each gear.

Can you draw an isometric circle that has a diameter of 60mm? In order to draw the isometric view of circles you must follow the steps shown in the diagrams below.

**isometric:** a 3D drawing where the lines of sight are set at 30°

**Step 1**  
Use the diameter of the circle to draw an isometric square.

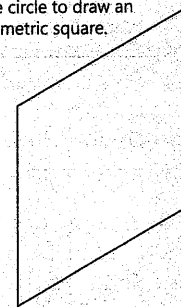


Figure 11.5

**Step 2**  
Draw the diagonals of the isometric square. (One long and the other short.)

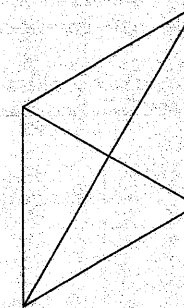


Figure 11.6

**Step 3**  
Draw the centre lines of the square. (Mid-point of one side to the mid-point of the opposite side.)

**Step 4**  
Draw lines from the ends of the short diagonal to the opposite mid-points (ab and cd).

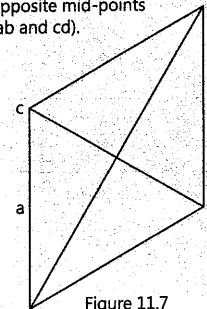


Figure 11.7

**Step 5**  
Identify the four centres (1, 2, 3 and 4). Two ends of the short diagonal and two points of intersection of the long diagonal and the lines from the short diagonal ends to the opposite mid-points.

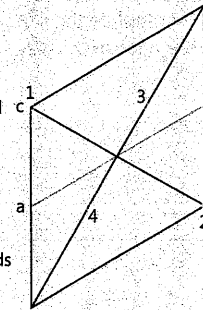


Figure 11.8

Step 6  
Use the radius 2-a and 3-b to draw the two arcs as shown.

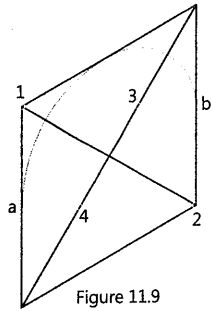


Figure 11.9

Step 7  
Complete the other two arcs to finish the isometric circle (1-b and 4-a).

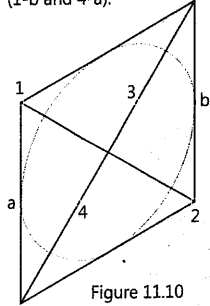


Figure 11.10

Copy the boxes shown below into your book. Draw the isometric circles in the boxes. Complete the drawing using the steps 1-7.

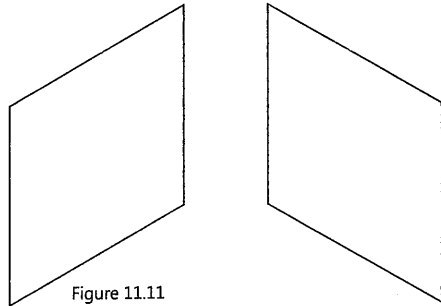


Figure 11.11

In the box shown below, the diagonals are drawn for you. First complete the isometric circle and then show the circle that lies at the back of the disc.

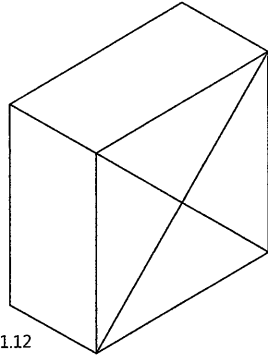


Figure 11.12

Let us look at the diameters of the two gears in the first device (a) that you designed.

The specifications required were:

$$\text{Mechanical advantage} = \frac{\text{driven}}{\text{driver}} = \frac{30}{10} = 3$$

Your driver gear may have a diameter of 10mm with a driven gear diameter of 30mm.

Draw an isometric sketch using instruments to show the gear system to meet the above specification.

**Hint:** Use a driver gear diameter of **60mm** and a driven gear diameter of **20mm**.

Look at the diagrams below and then draw an isometric view of the disc (driver gear) from which the gear will be machined (cut).

Remember that you will need to draw the circle at the back of the driver gear showing the thickness of the disc. Can you figure out how to draw this?

**Isometric projection graphically showing gear systems**

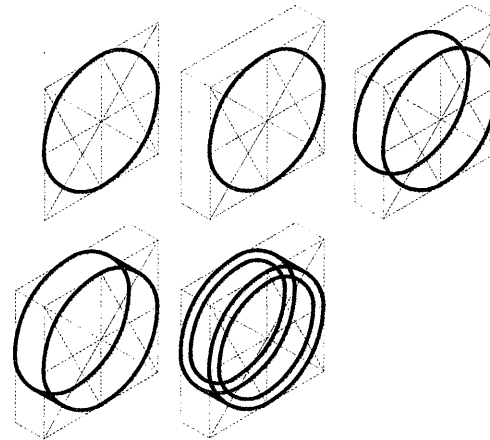


Figure 11.13 Isometric projection of gear systems



Figure 11.14

Now draw the driven gear (also in its position) such that your drawing indicates that the two gears are in mesh.

Look at the second device B that you designed. Draw the isometric sketch of two gears that will give an output velocity of four times.

**Hint:** Speed increases four times.

### 2D sketches showing gear systems

Earlier in this term you had to draw gear systems. When finding mechanical advantage you also noted how the number of teeth on the gears increases or decreases.

The diameters of the gears will also be affected as a result of changes in input force and output force.

These gear changes can be shown graphically in drawings so that the information can be easily communicated to others.

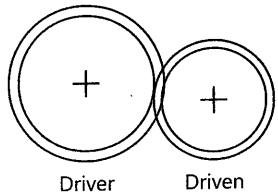


Figure 11.15

Shown alongside is the method of graphically showing gears in mesh. You only need to indicate the number of teeth. There is no need to draw the teeth.

If a gear system has a mechanical advantage of four, it means that the output force is four times greater than the input force.

How is this achieved?

It means that the output gear must be four times larger than the input gear.

### ACTIVITY 2 2D SKETCHES SHOWING GEAR SYSTEMS

Use a compass, ruler and pencil to draw the following gear trains by using the appropriate graphic symbols:

1. If an input gear has a diameter of 20mm, draw an accurate 2D sketch of the gear train required to give the MA = 4:1.

Before you start your drawing check your answers to the following carefully:

- What is the diameter of the output gear?

- If the input gear has 12 teeth, how many teeth must the output gear have?
- Does your drawing look anything like the drawing below?

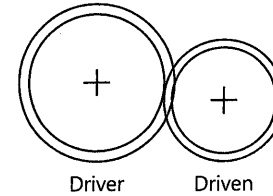


Figure 11.16

- Remember to indicate the number of teeth for each gear used.
  - Show clearly the driver and driven gear.
  - Indicate direction of movement of each gear.
2. Using a compass, draw a graphical representation (2D sketch) of a gear system that will **double the rotation** rate on a driven axle that is at **90°** to the driver axle.

Firstly, check what speed advantage is obtained.

Which graphic symbol shown below best describes the type of gear you are drawing?

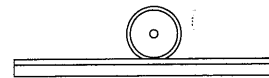


Figure 11.17 Rack and pinion

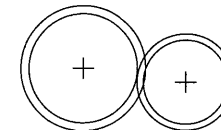


Figure 11.18 Spur gears

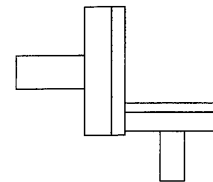


Figure 11.19 Bevel gears

Now draw the graphical representation you have chosen using the correct size of gears that will give **double the rotation**.

In order to understand how cyclists use gears to their best advantage you must look carefully at the construction of a bicycle.

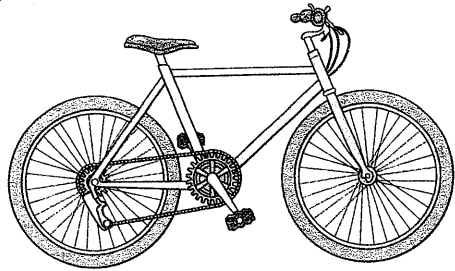


Figure 11.20 Bicycle

A bicycle has a sprocket and chain system. The pedals are fixed to a large gear (driver or master gear). The chain is attached to the different gears (cogs) on the back wheel (driven or slave gears). These driven gears are of various sizes, allowing the cyclist to select different gears for increased speed or greater force.

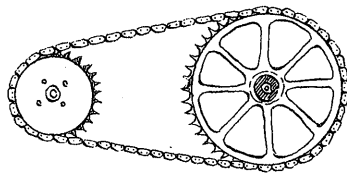


Figure 11.21 Gear selection A

**Gear selection A**

Selecting the bigger driven wheel (cog) on the back wheel allows for slower cycling but with a bigger force. Bigger force is good for riding uphill and is easier for the cyclist to pedal.

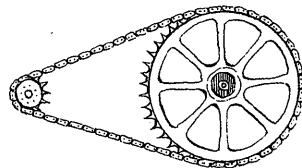


Figure 11.22 Gear selection B

**Gear selection B**

Selecting the smaller driven wheel (cog) on the back wheel allows greater speed but with less force. It is difficult for the cyclist to pedal.

**ACTIVITY 3 HOW WILL YOU ADVISE A CYCLIST?**

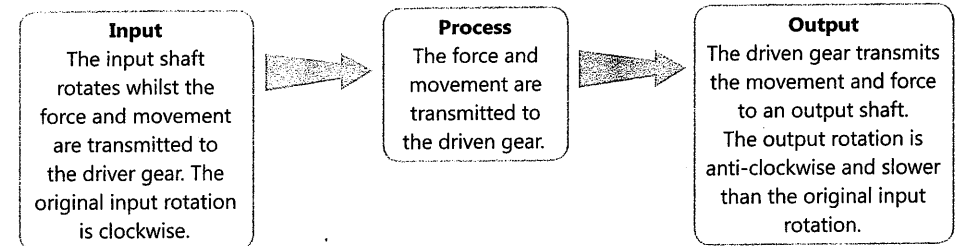
1. A cyclist should use the biggest cog when riding down a steep slope. Is this a good idea?
2. A cyclist riding on a flat road should use the smallest cog. What is your advice?

**Systems diagrams**

We use systems diagrams to analyse a mechanical system by breaking it into input, process and output.

**Gearing down**

Gearing down is when the driven gear rotates slower than the driver gear.



**ACTIVITY 4 MECHANICAL ADVANTAGE OF A GEAR SYSTEM**

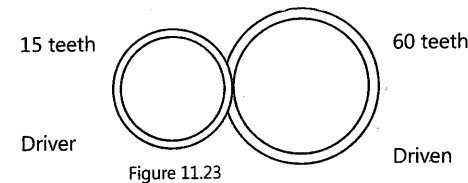


Figure 11.23

1. Draw the diagram as shown above.
2. Does the driven gear rotate slower or faster than the driver?
3. Calculate the mechanical advantage of this system.

**Gearing up**

Gearing up is when the driven gear rotates faster than the driver gear.

