



Education

KwaZulu-Natal Department of Education
REPUBLIC OF SOUTH AFRICA

**NATIONAL
SENIOR CERTIFICATE**

GRADE 12

LIFE SCIENCES

COMMON TEST

JUNE 2018

MARKS: 150

TIME: 2½ hours

N.B. This question paper consists of 13 pages including this page.

INSTRUCTIONS AND INFORMATION

Read the following instructions carefully before answering the questions.

1. Answer ALL the questions.
2. Write ALL the answers in the ANSWER BOOK.
3. Start the answers to EACH question at the top of a NEW page.
4. Number the answers correctly according to the numbering system used in this question paper.
5. Present your answers according to the instructions of each question.
6. Make ALL drawings in pencil and label them in blue or black ink.
7. Draw diagrams, tables or flow charts only when asked to do so.
8. The diagrams in this question paper are NOT necessarily drawn to scale.
9. Do NOT use graph paper.
10. You must use a non-programmable calculator, protractor and a compass, where necessary.
11. Write neatly and legibly.

SECTION A**QUESTION 1**

1.1 Various options are provided as possible answers to the following questions. Choose the correct answer and write only the letter (A to D) next to the question number (1.1.1 to 1.1.9) in your ANSWER BOOK, for example 1.1.10 D.

1.1.1 The physiological connection between the axon of one neuron and the dendrite of another is a ...

- A ganglion.
- B synapse.
- C capillary network.
- D cell body.

1.1.2 At the end of meiosis II four daughter cells had 6 chromosomes each.

How many chromosomes did each cell have at the end of meiosis I?

- A 3
- B 6
- C 12
- D 24

1.1.3 With external fertilisation ...

- A physical contact between the male and female is always required.
- B there is little wastage of eggs and sperm.
- C the eggs need to remain in water or a moist environment to prevent dehydration.
- D a small amount of eggs and sperm are required.

1.1.4 In fruit flies, the allele for red eyes (**R**) is dominant and the allele for brown eyes (**r**) is recessive.

What are the possible combinations of alleles in the offspring of two red-eyed heterozygous flies?

- A **RR** only
- B **rr** only
- C **Rr** and **rr** only
- D **RR**, **Rr** and **rr**

QUESTIONS 1.1.5 AND 1.1.6 REFER TO THE INVESTIGATION BELOW.

An investigation was conducted to determine the effect of alcohol on reaction time.

The procedure was as follows:

- 100 adult volunteers participated in the investigation.
- Their reaction time was measured at the beginning of the investigation.
- They were each given alcohol to drink.
- Their reaction time was measured again after 20 minutes.

1.1.5 The following factors were considered during the investigation:

- (i) Volume of alcohol consumed
- (ii) Age of volunteers
- (iii) Number of volunteers
- (iv) Tool used to measure reaction time

Which ONE of the following combinations of factors will affect the validity of the investigation?

- A (i) and (ii) only
- B (i), (ii) and (iv) only
- C (i), (ii), (iii) and (iv)
- D (ii), (iii) and (iv) only

1.1.6 What is the independent variable in the above investigation?

- A Number of volunteers
- B Reaction time
- C Time after drinking alcohol
- D Alcohol in the body

1.1.7 Which ONE of the following is a function of the umbilical cord?

- A Regulates foetal temperature
- B Transports waste from the placenta to the foetus
- C Protects the foetus against mechanical injury
- D Transports nutrients from the placenta to the foetus

1.1.8 Chromosomes arrange themselves randomly along the equator during ...

- A Prophase I.
- B Metaphase I.
- C Anaphase I.
- D Telophase I.

1.1.9 The sequence of nitrogenous bases UCA CGA ACC GCU AAC could represent ...

- A a gene that codes for one polypeptide.
- B an mRNA strand that codes for five amino acids.
- C a DNA strand that codes for one mRNA molecule.
- D a polypeptide chain of five codons.

(9 x 2) (18)

1.2 Give the correct **biological term** for each of the following descriptions. Write only the term next to the question number (1.2.1 to 1.2.8) in the ANSWER BOOK.

1.2.1 A change in the environment that causes the body to elicit a response

1.2.2 The point at which chromosomes overlap during crossing over

1.2.3 A type of reproduction in animals whose offspring are born alive once they are fully developed

1.2.4 The organelle where translation takes place during protein synthesis

1.2.5 A part of the brain that controls the breathing rate

1.2.6 Nervous disorder characterised by the degeneration of the dendrites of the neurons

1.2.7 The division of the cytoplasm through the constriction of the cell membrane at the end of cell division

1.2.8 The failure of chromatids to separate during anaphase II

(8 x 1) (8)

- 1.3 Indicate whether each of the descriptions in COLUMN I applies to **A ONLY**, **B ONLY**, **BOTH A AND B** or **NONE** of the items in COLUMN II. Write **A only**, **B only**, **both A and B** or **none** next to the question number (1.3.1 to 1.3.4) in the ANSWER BOOK.

COLUMN I		COLUMN II	
1.3.1	May contain uracil as a nitrogen base	A:	mRNA
		B:	tRNA
1.3.2	Transmits sound waves towards the tympanic membrane	A:	Oval window
		B:	Round window
1.3.3	A type of development in birds in which offspring are poorly developed at birth and are thus unable to feed themselves	A:	Precocial development
		B:	Altricial development
1.3.4	Phase in which DNA replication occurs	A:	Interphase
		B:	Prophase

(4 x 2)

(8)

- 1.4 Study the diagram below of a human brain.

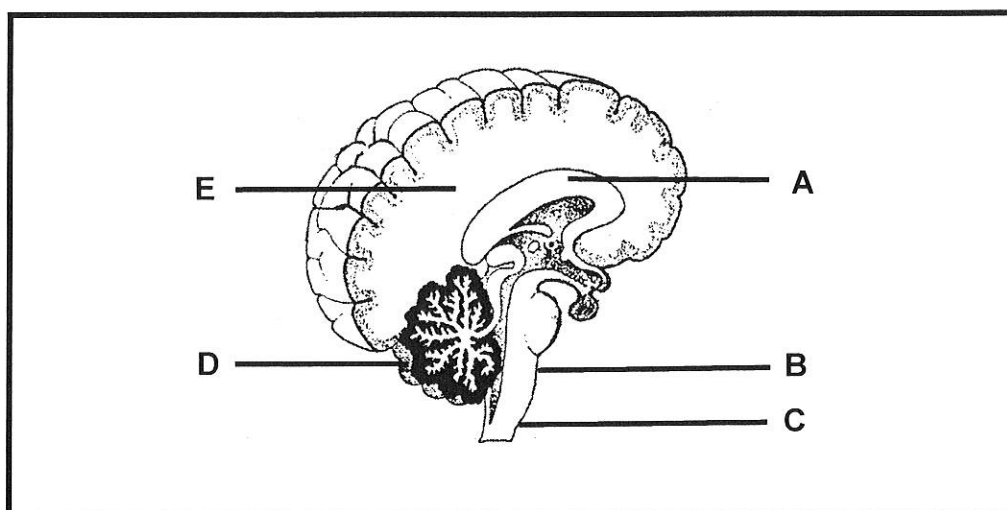

- 1.4.1 Identify part E. (1)
- 1.4.2 A drunk person has difficulty walking in a straight line.
Write down the LETTER and the NAME of the part that is most probably affected by alcohol. (2)
- 1.4.3 Explain why damage to part B leads to death almost instantly. (2)
- 1.4.4 State TWO ways in which the brain is protected. (2)
- (7)

1.5 The diagram below shows a cell during a phase in meiosis.

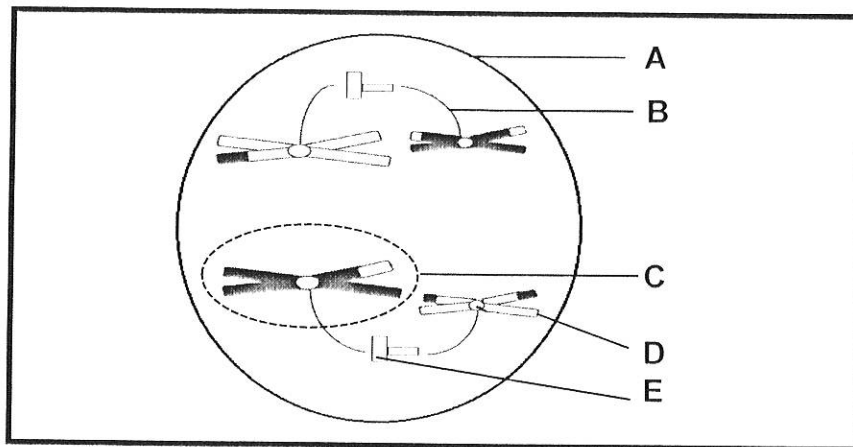

1.5.1 Identify part:

- | | | |
|-----|---|-----|
| (a) | A | (1) |
| (b) | B | (1) |
| (c) | C | (1) |
| (d) | D | (1) |
| (e) | E | (1) |

1.5.2 Identify the phase shown in the diagram. (1)

1.5.3 Give ONE reason for your answer to QUESTION 1.5.2. (1)

1.5.4 How many chromosomes does this cell have? (1)

1.5.5 Name the process in meiosis that led to a difference in the composition of the genetic material in structure C. (1)
(9)

TOTAL SECTION A: 50

SECTION B

QUESTION 2

2.1 Study the following diagram.

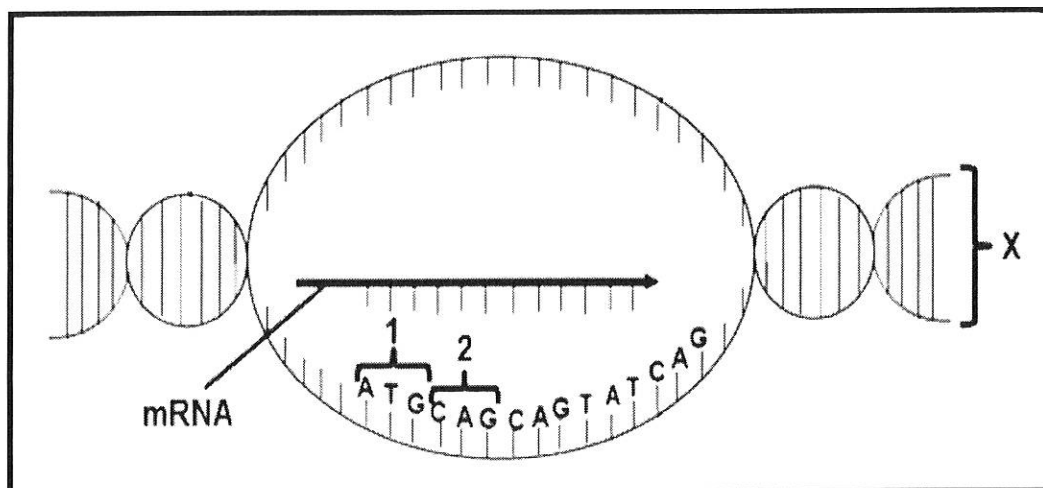

2.1.1 Identify molecule **X**. (1)

2.1.2 Give TWO visible reasons for your answer in QUESTION 2.1.1. (2)

2.1.3 The table below shows amino acids coded for by different mRNA codons.

Codons on mRNA coding for the amino acid	Amino acid coded for
GUC	Glutamate
AUA	Histidine
GGA	Proline
UAC	Valine
GAC	Leucine
UGA	Threonine

(a) Using the table above, write down the amino acid that is coded for by triplet **2**. (1)

(b) Write down the anti-codon for histidine. (2)

(c) State the effect of a mutation on the protein formed if the **A** in triplet **1** changes to **C**. (2)

2.1.4 Describe the formation of mRNA. (6)

2.1.5 State ONE difference between the events of DNA replication and the formation of mRNA. (2)

(16)

2.2 The glands of the male reproductive system produce many secretions.

2.2.1 State TWO general functions of the fluids secreted by the accessory glands of the male reproductive system. (3)

2.2.2 State any TWO physical changes in males during puberty. (2)

2.2.3 Describe the process of spermatogenesis. (5)
(10)

2.3 During a genetic research in a certain country, information was gathered on the number of people living with genetic disorders caused by mutations. The total population of this country was 142 million.

The results are shown in the table below.

Genetic disorder	Number of people
Down syndrome	18 000
Haemophilia	22 560
Colour-blindness	98 000

2.3.1 According to the results, which is the most common genetic disorder in this country? (1)

2.3.2 Explain why the chance of being colour-blind is smaller in women than in men. (3)

2.3.3 Describe how a mutation on the DNA molecule may lead to haemophilia. (4)

2.3.4 Draw a pie chart to represent the results in the table. Show your calculations. (6)
(14)
[40]

QUESTION 3

3.1 The diagram below represents a neuron.

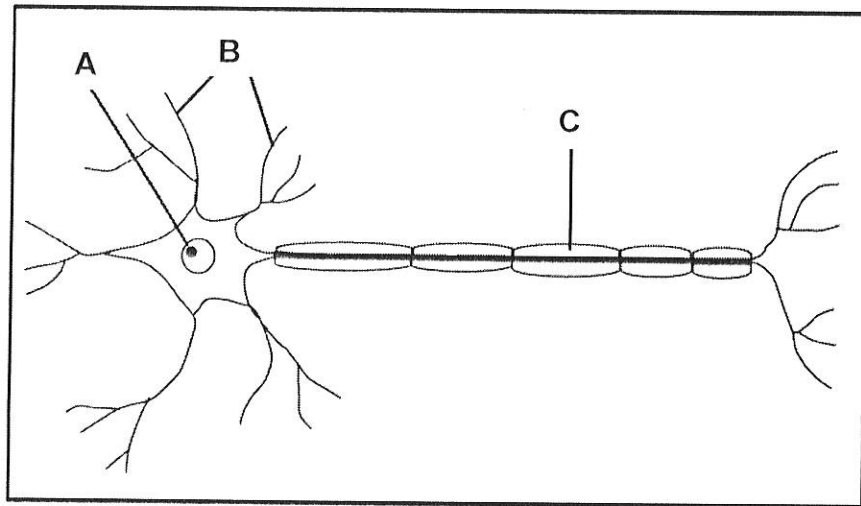

3.1.1 Identify the type of neuron shown in the diagram. (1)

3.1.2 State ONE function of this type of neuron. (1)

3.1.3 Write down the LETTER only of the part that:

(a) Transmits impulses towards the cell body (1)

(b) Controls all the activities of the neuron (1)

3.1.4 Name the nervous disorder that results when part C is damaged. (1)

3.1.5 State TWO symptoms of the disorder mentioned in QUESTION 3.1.4 above. (2)
(7)

3.2 Genetic engineering uses biotechnology to satisfy human needs.

3.2.1 Describe the steps involved in the process of genetic modification such as in the production of insulin. (5)

3.2.2 State THREE benefits of genetic modification in crop production. (3)
(8)

3.3 The pedigree diagram below shows the inheritance of agammaglobulinemia (a lack of immunity to infections) which is a sex-linked genetic disorder in humans caused by a recessive allele. The dominant allele is represented by X^A and the recessive allele is represented by X^a .

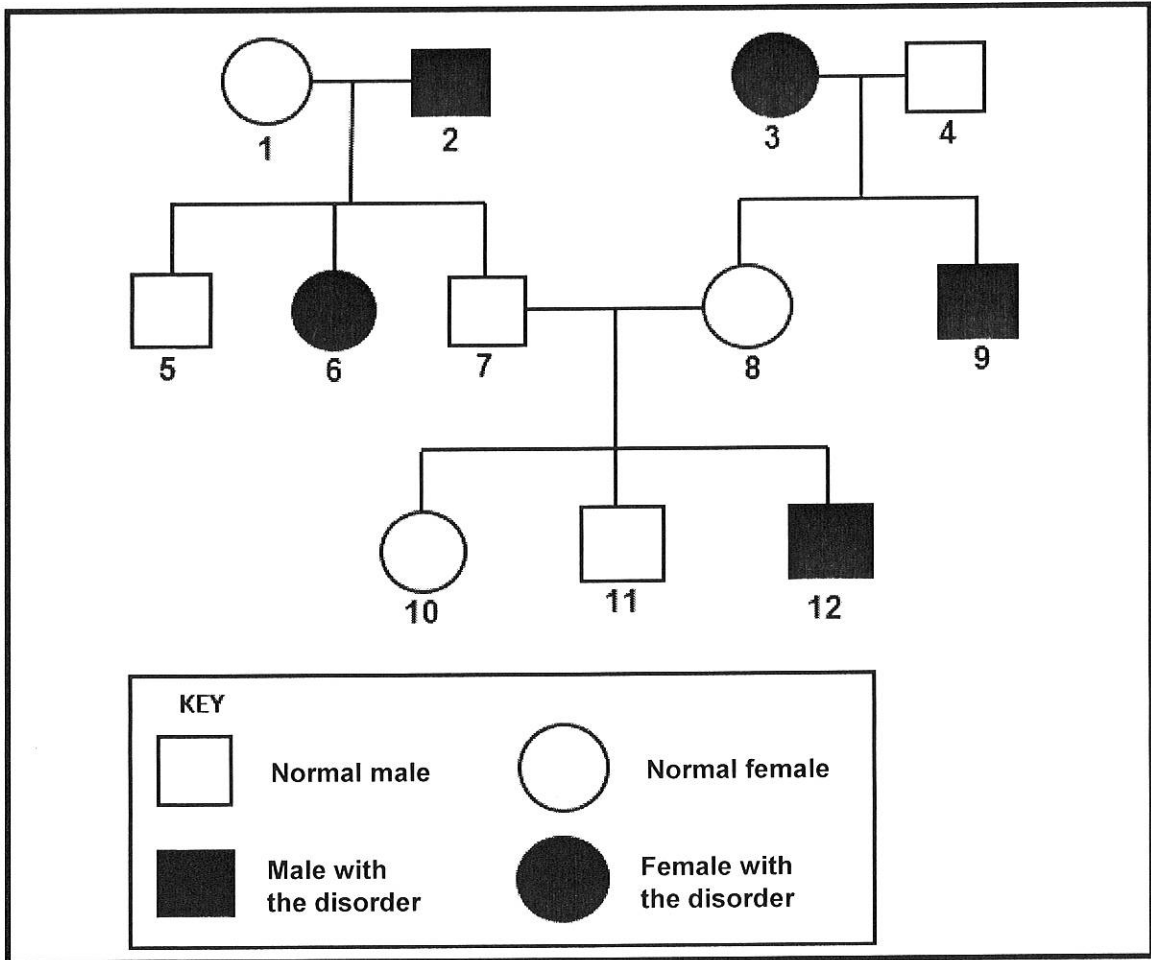

3.3.1 How many of the male offspring of parents **1** and **2** were normal? (1)

3.3.2 Write down the genotype of:

(a) Individual **2** (1)

(b) Individual **6** (1)

3.3.3 Write down the NUMBER only of TWO individuals who are definitely heterozygous for the genetic disorder mentioned above. (2)

3.3.4 State the type of dominance shown by this disorder. (1)

3.3.5 Individuals **3** and **4** decided to have another child.

Represent a genetic cross to show the possible genotypes and phenotypes of their children.

(6)
(12)

3.4 The diagram below shows a human ovary.

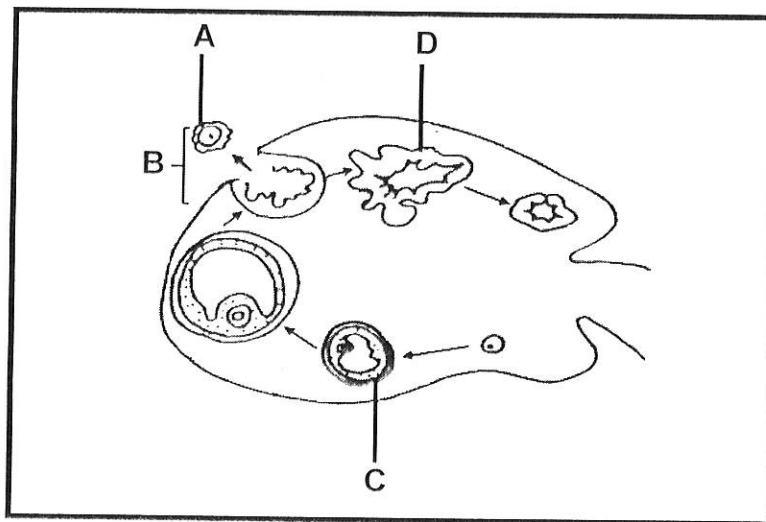

The table below shows the concentration of two pituitary hormones as measured in a healthy female over a 28 day cycle.

DAYS	Hormone concentration (arbitrary units)	
	LH	FSH
4	0,5	0,7
8	0,5	2,8
12	2,4	4,4
16	8,5	6,5
20	1,9	3,5
24	0,5	0,5
28	0,5	2,2

- 3.4.1 Identify structure **C**. (1)
- 3.4.2 Explain the consequence if structure **C** did not produce its hormone. (2)
- 3.4.3 Provide evidence from the table which indicates that process **B** took place around day 16. (2)
- 3.4.4 Provide evidence which suggests that fertilisation did not take place during the 28-day cycle using information from the:
- (a) Diagram (2)
- (b) Table (2)
- 3.4.5 Fertilisation occurs when structure **A** fuses with a sperm cell.

Describe the development of a fertilised egg cell until it becomes a foetus.

(4)
(13)
(40)
[80]

TOTAL SECTION B:

SECTION C**QUESTION 4**

While walking barefoot, looking into the distance, Shaleen accidentally stepped on a thorn and quickly removed her foot and hopped to a seat to remove the thorn.

Describe the reflex action that allowed her to remove her foot from the ground and how she maintained balance as she hopped to the seat. Also describe how she kept the image of her foot in focus while pulling out the thorn.

Content: (17)
Synthesis: (3)
(20)

NOTE: NO marks will be awarded for answers in the form of flow charts, tables or diagrams.

TOTAL SECTION C: (20)
GRAND TOTAL: [150]

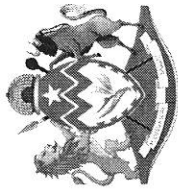

Education

KwaZulu-Natal Department of Education
REPUBLIC OF SOUTH AFRICA

LIFE SCIENCES

PROVINCIAL COMMON TEST

MEMORANDUM - JUNE 2018

NATIONAL
SENIOR CERTIFICATE

GRADE 12

MARKS: 150

This memorandum consists of 10 pages.

Copyright reserved

Please turn over

PRINCIPLES RELATED TO MARKING LIFE SCIENCES

- If more information than marks allocated is given**
Stop marking when maximum marks is reached and put a wavy line and 'max' in the right-hand margin.
- If, for example, three reasons are required and five are given**
Mark the first three irrespective of whether all or some are correct/incorrect.
- If whole process is given when only a part of it is required**
Read all and credit the relevant part.
- If comparisons are asked for, but descriptions are given**
Accept if the differences/similarities are clear.
- If tabulation is required, but paragraphs are given**
Candidates will lose marks for not tabulating.
- If diagrams are given with annotations when descriptions are required**
Candidates will lose marks.
- If flow charts are given instead of descriptions**
Candidates will lose marks.
- If sequence is muddled and links do not make sense**
Where sequence and links are correct, credit. Where sequence and links are incorrect, do not credit. If sequence and links become correct again, resume credit.
- Non-recognised abbreviations**
Accept if first defined in answer. If not defined, do not credit the unrecognised abbreviation, but credit the rest of the answer if correct.
- Wrong numbering**
If answer fits into the correct sequence of questions, but the wrong number is given, it is acceptable.
- If language used changes the intended meaning**
Do not accept.
- Spelling errors**
If recognisable, accept the answer, provided it does not mean something else in Life Sciences or if it is out of context.
- If common names are given in terminology**
Accept, provided it was accepted at the national memo discussion meeting.
- If only the letter is asked for, but only the name is given (and vice versa)**
Do not credit.
- If units are not given in measurements**
Candidates will lose marks. Memorandum will allocate marks for units separately.
- Be sensitive to the sense of an answer, which may be stated in a different way.**
- Caption**
All illustrations (diagrams, graphs, tables, etc.) must have a caption.

Copyright reserved

SECTION A

QUESTION 1

1.1	1.1.1	B✓✓	
	1.1.2	B✓✓	
	1.1.3	C✓✓	
	1.1.4	D✓✓	
	1.1.5	B✓✓	
	1.1.6	D✓✓	
	1.1.7	D✓✓	
	1.1.8	B✓✓	
	1.1.9	B✓✓	
1.2	1.2.1	Stimulus✓	
	1.2.2	Chiasma✓	
	1.2.3	Vivipary✓/ Viviparous	
	1.2.4	Ribosome✓	
	1.2.5	Medulla oblongata✓	
	1.2.6	Alzheimers disease✓	
	1.2.7	Cytokinesis✓	
	1.2.8	Non-disjunction✓	
1.3	1.3.1	Both A and B✓✓	(8)
	1.3.2	None✓✓	(2)
	1.3.3	B only✓✓	(2)
	1.3.4	A only✓✓	(2)
1.4	1.4.1	Cerebrum✓	(1)
	1.4.2	D✓ - Cerebellum✓	(2)
	1.4.3	- Heart-beat will not be controlled✓ - therefore blood flow to the cells will be affected✓ OR - No breathing control✓ - therefore cells are deprived of oxygen✓	(2)
	1.4.4	- Cerebrospinal fluid✓ - Meninges✓ - Cranium✓	Any 2 (2)

(Mark the FIRST TWO only)

(9 x 2) (18)

QUESTION 2

1.5	1.5.1	(a) Cell membrane✓ (b) Spindle fibre✓ (c) Chromosome✓ (d) Chromatid✓ (e) Centriole✓	(1) (1) (1) (1) (1)
	1.5.2	Anaphase I✓	(1)
	1.5.3	Chromosomes are moving apart✓	(1)
	1.5.4	4✓	(1)
	1.5.5	Crossing over✓	(1)

TOTAL SECTION A: 50

QUESTION 2

2.1	2.1.1	DNA✓	(1)
	2.1.2	- It has thymine✓ - It is double stranded✓ (Mark the FIRST TWO only)	(2)
	2.1.3	(a) Glutamate✓ (b) UAU✓✓ (c) - The protein will now have Leucine✓ - Instead of Valine✓	(1) (2) (2)
	2.1.4	Transcription ✓ - Double stranded DNA unwinds✓ - and unzips✓/weak hydrogen bonds break - One strand is used as template✓ - to form mRNA✓ - using free nucleotides from the nucleoplasm✓ - The mRNA is complementary to the DNA✓ - mRNA now has the coded message for protein synthesis✓	Any 6 (6)
	2.1.5	- In DNA replication two strands are used as templates✓ - while in transcription one strand is used✓ - DNA complementary strand has thymine✓ - while mRNA has uracil✓ - In DNA replication the whole✓ molecule unzips - while only the coding part unzips in transcription (mRNA formation)✓	Any 1 x 2 (2)

(Mark the FIRST ONE only)

(16)

- 2.2 2.2.1 - Produces sperms ✓
 - Nourishes sperms ✓
 - Provides medium for the movement of sperms ✓
 - Protects the sperms against vaginal acid ✓
(Mark the FIRST THREE only) Any 3 (3)
- 2.2.2 - Sexual organs grow bigger ✓
 - Pubic hair grows in private areas ✓
 - Becomes muscular ✓
 - Shoulders broaden ✓
 - Voice gets deeper ✓
(Mark the FIRST TWO only) Any 2 (2)
- 2.2.3 - Under the influence of testosterone ✓
 - diploid ✓ cells
 - in the seminiferous tubules ✓ / testis
 - undergo meiosis ✓
 - to form haploid ✓ sperm cells Any 5 (5)
(10)
- 2.3 2.3.1 Colour-blindness ✓ (1)
- 2.3.2 - Since females has 2 X-chromosomes ✓
 - they need to inherit two recessive alleles to have the disorder ✓
 - Since males have 1 X-chromosome ✓
 - They only require one recessive allele to have the disorder ✓ Any 3 (3)
- 2.3.3 - The DNA code will change ✓
 - A different codon will be formed on the mRNA ✓
 - which will complement a different tRNA ✓
 - with a different amino acid ✓
 - The clotting protein will therefore not to be formed ✓ leading to haemophilia Any 4 (4)

2.3.4

Down syndrome
 $18\,000 / 138\,560 \times 360^\circ$
 = $46,8^\circ$

Haemophilia
 $22\,560 / 138\,560 \times 360^\circ$
 = $58,6^\circ$

Colour-blindness
 $98\,000 / 138\,560 \times 360^\circ$
 = $254,6^\circ$

Number of people living with genetic disorders

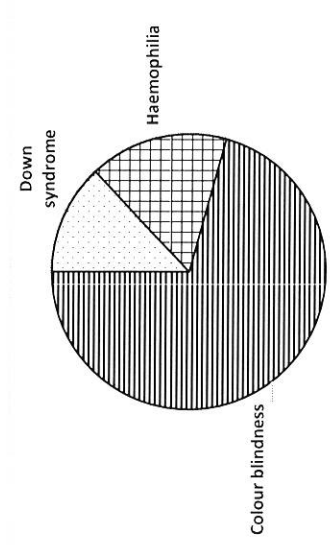

Criteria	Marks
Type of graph	1 mark
Caption	1 mark
Calculations	No calculations correct – 0 mark 1-2 calculations correct – 1 mark All 3 calculations correct – 2 marks
Correct proportion for each labelled slice	No proportions correct – 0 mark 1 proportion correct – 1 mark 3 proportions correct – 2 marks

(6)
 (14)
 [40]

QUESTION 3

- 3.1 3.1.1 Motor neuron ✓ (1)
- 3.1.2 Carries impulses from the central nervous system to the effectors ✓ (1)
- 3.1.3 (a) B ✓ (1)
(b) A ✓ (1)
- 3.1.4 Multiple sclerosis ✓ (1)
- 3.1.5
- Muscle pains ✓
 - Spasms ✓
 - Numbness in legs ✓
 - Speech difficulties ✓
 - Poor judgement ✓
 - Memory loss ✓
 - Decreased attention span ✓
- (Mark the FIRST TWO only) Any 2 (2)
(7)
- 3.2 3.2.1
- The insulin gene is extracted from an organism ✓
 - The bacterial plasmid is split ✓ by enzymes ✓
 - The insulin gene is inserted into the plasmid ✓
 - The altered plasmid is inserted back into the bacterium ✓
 - The bacteria reproduce rapidly ✓ asexually ✓
 - Many bacteria now contain the insulin gene ✓ and will produce insulin ✓ in large quantities
- Any 5 (5)
- 3.2.2
- Increase crop yield ✓
 - Reduce plant vulnerability to drought ✓
 - Improves nutrition, taste, texture and appearance of food ✓
 - Increase resistance to pests and diseases ✓
 - Increases shelf life ✓
- (Mark the FIRST THREE only) Any 3 (3)
(8)
- 3.3 3.3.1 2 ✓ (1)
- 3.3.2 (a) X^aY ✓ (1)
(b) X^aX^a ✓ (1)
- 3.3.3 1 ✓ and 8 ✓ (2)
(Mark the FIRST TWO only)
- 3.3.4 Complete dominance ✓ (1)

3.3.5 P₁ Phenotype Genotype

Meiosis G/Gametes

Fertilisation

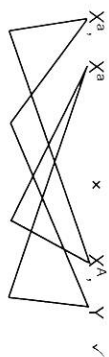

F₁ Genotype Phenotype
P₁ and F₁ ✓
Meiosis and fertilisation ✓

Female with disorder × Normal male ✓
X^aX^a × X^AY ✓
x x
X^a X^A Y ✓
X^a X^A Y ✓
Normal Male with ✓
Female the disorder female the disorder

Any 6

P₁ Phenotype Genotype
Meiosis

Fertilisation

F₁

Phenotype

P₁ and F₁ ✓
Meiosis and fertilisation ✓

Female with disorder × Normal male ✓
X^aX^a × X^AY ✓

OR

Gametes	X ^a	X ^a	X ^A
X ^a	X ^a X ^a	X ^a X ^a	X ^a X ^A
Y	X ^a Y	X ^a Y	X ^A Y

✓ (correct gametes)
✓ (correct genotype)

2 normal females : 2 males with the disorder ✓

Any 6 (6)
(12)

3.4 3.4.1 Graafian follicle ✓ (1)

3.4.2 - Endometrium will not be thickened ✓
 - Implantation will not occur ✓
 - Miscarriage will occur ✓ Any 2 (2)

3.4.3 - LH ✓ is at its highest ✓
OR
 - FSH ✓ is at its highest ✓ (2)

3.4.4 (a) Structure D ✓ / corpus luteum degenerates ✓ (2)

(b) FSH ✓ level rises ✓
OR
 LH ✓ level drops ✓ (2)

3.4.5 - Zygote is formed ✓
 - It divides by mitosis ✓ repeatedly to form a solid ball of cells ✓
 - called a morula ✓
 - which then forms a hollow ball of cells ✓
 - called a blastocyst ✓ which then develops into a foetus Any 4 (4)

(13)
[40]

QUESTION 4

Reflex action

- Pain receptors in the foot ✓
- converted the stimulus of pain into an impulse ✓
- which was transmitted by the sensory neuron ✓ to the spinal cord ✓
- The impulse was then transferred to the connector neuron ✓
- which transmitted the impulse to the motor neuron ✓
- by synaptic contact ✓
- The impulse is then transmitted to the effector muscles ✓ of the leg
- causing them to contract ✓ to pull the foot away from the thorn

Max 7

Balance

- A change in speed and direction ✓
- stimulated the cristae ✓
- A change in the position of the head ✓ / body
- stimulated the maculae ✓
- The stimulus was converted into an impulse ✓
- which was sent to the cerebellum ✓
- via the auditory nerve ✓
- Impulses were then sent to the muscles ✓ to restore balance

Max 6

Accommodation for near vision

- The ciliary muscles contract ✓
- causing the suspensory ligaments to slacken ✓
- The lens becomes more convex ✓
- and its refractive power increases ✓
- so that a clear image is formed on the retina ✓

Max 4

Content: (17)
 Synthesis: (3)
(20)

ASSESSING THE PRESENTATION OF THE ESSAY

Relevance	Logical sequence	Comprehensive
All information provided is relevant to the topic	Ideas arranged in a logical/ cause-effect sequence	Answered all aspects required by the essay in sufficient detail
Only the information relevant to	Logical sequence of events in:	Includes at least the following:
- Reflex action	- Reflex action	- Reflex action = 5/7
- Balance	- Balance	- Balance = 3/6
- Accommodation is given.	- Accommodation is provided.	- Accommodation = 3/4
There is no irrelevant information.		
1 mark	1 mark	1 mark

TOTAL SECTION C: 20
GRAND TOTAL: 150

