



education

Department:
Education
PROVINCE OF KWAZULU-NATAL

CURRICULUM GRADE 10 – 12 DIRECTORATE

NCS (CAPS) SUPPORT DOCUMENT

GRADE 12

MATHEMATICAL LITERACY

STEP AHEAD PROGRAMME

2021

LEARNER PREFACE GRADE 12

This support document serves to assist Mathematical Literacy learners on how to deal with curriculum gaps and learning losses as a result of the impact of COVID – 19 in 2020. It also captures the challenging topics in the Grade 12 work. Activities serve as a guide on how various topics are assessed at different cognitive levels and will also assist in preparing learners for informal and formal tasks in Mathematical Literacy. It is important that learners do these activities to reinforce what has been taught in class. It will cover the following topics:

A	Basic skills	
B	Finance	
C	Measurement	
D	Map and Plans	
E	Data Handling	
E	Probability	

TOPIC:FINANCE
SECTION:TAXATION
OBJECTIVES
<p>By the end of this section the learners should to be able to:</p> <ul style="list-style-type: none">● Explain concepts such as, (Income tax, gross income, tax rebates, tax threshold, etc.)● Determine an individual taxable income● Calculate personal income tax● Determine net pay● Identify the name of the employee listed on a pay slip and the month for which the pay slip has been issued.● Identify the employee's monthly salary.● Explain how the employees "taxable income" has been determined by referring to the salary and deduction values shown on the payslip.● Explain the meaning of the terms "gross pay", "net pay", "deductions", and "taxable income" shown on a payslip.● Read appropriate tax values from given income tax deduction tables.● Identify the income tax bracket into which an individual falls based on a given monthly and/or annual income.● Use formulae provided on income tax bracket tables to calculate an individual's annual and monthly income tax.● Investigate through calculation how the tax rebate value is determined. Compare income tax tables over different financial periods and explain how an individual's tax may have changed from one period to another.● Investigate the effect that an● increase in salary has on increased tax payments.
TERMINOLOGY
<ul style="list-style-type: none">● Gross income: is the total income received by an employee/individual before deductions are taken out or subtracted.● Taxable income: Is an amount of money that an employee or individual receives after an amount of pension fund contribution has be subtracted or deducted.● Tax threshold: it determines whether an individual is required to pay income tax (PAYE) or not according to their specified income level and age.● Tax rebates: Is an amount which reduces the amount of tax that an individual was supposed to pay according to their age. In other words, it must be subtracted on the Income tax a person must pay.● Medical tax credits: it also reduces an amount of income tax, but only for those individuals that have a medical aid scheme.● Taxable deductions i.e. medical aid and pension fund UIF● Non-taxable deductions i.e. car allowance
NOTES

<p>Taxation and Income Tax</p> <p>Two types of Tax</p> <ul style="list-style-type: none">• VAT: The money paid by consumers (people buying) and businesses.• Income Tax: The money paid by working people, earning a salary above the tax threshold. <p>All income tax and VAT is paid to SARS.= 4 km</p> <p>Summary:</p> <ol style="list-style-type: none">1. If needed MEASURE lengths on paper2. Write down the scale.3. Write the corresponding lengths beneath each other.4. Apply one of the two methods or the method that you're used to or know.5. Convert to appropriate/unit requested. <p>Know your conversions!</p>	<p>Explain the difference between “taxation” and tax:</p> <ul style="list-style-type: none">• Taxation: The government’s process of getting tax money from the workers or businesses.• Tax: The money that a person or business pay to SARS. <p>Ask the learners to explain “income tax”. Use the learners’ explanation to give further explanation of income tax.5. Convert to appropriate / unit as requested. Know your conversions!</p>
<p>Step 1:</p> <p>Calculating Income Tax:</p> <ul style="list-style-type: none">• Calculate the annual income.• Multiply the monthly salary by 12 to make it the annual salary and add extra benefits.	<p>Explain the terms:</p> <p>Annual income: All the income a person earned over the year.</p> <p>Income is:</p> <ul style="list-style-type: none">• wages (money earned per hour);• salary (money earned per month);• bonuses;• commissions; and• Overtime. <p>Do not use only salary to calculate income.</p>



<p>Step 2: Calculating non-taxable income:</p> <ul style="list-style-type: none"> • UIF- 1% of income • Pension fund: 7,5% • Donations (charity gift to charity organisation) • Child support payments <p>A donation will be exempted(not added) if the total value of donations for a year of assessment is not more than:</p> <ul style="list-style-type: none"> • casual gifts by companies and trusts:R10 000; and • Donations by individuals: R100 000. 	<p>Explain the concepts. Assist learners to find the non-taxable income on the Salary advice.</p>
<p>Step 3: Calculating the taxable income: Taxable income = total income - non-taxable income</p>	
<p>Step 4 Tax threshold:</p> <ul style="list-style-type: none"> • Use the tax table to see if the person must pay tax. • The person whose income is lower than the tax threshold does not pay tax. 	<p>Ask the learners to look at the tax table. See if the person must pay tax. Explain tax threshold.</p>
<p>Step 5:</p> <ul style="list-style-type: none"> • Identify the tax bracket. • Copy the bracket. • Calculate payable tax before the rebates and medical credits could be subtracted. <p>NB: Remember order of calculations!</p>	
<p>Step 6:</p> <ul style="list-style-type: none"> • Identify the rebate. • Calculate the annual medical credits. • Subtract the rebate and medical credits from the calculated tax in step 4. <p>Rebate:</p> <ul style="list-style-type: none"> • Is the tax relief(pay less). • It is deducted after annual tax has been calculated. • The older the person, the higher the rebate. • People younger than 65 get the primary rebate. • People above 65 qualify for both primary and secondary rebates. • People above 75 qualify for primary, secondary and tertiary rebates. 	<p>Explain “tax rebate”. Show the tax table to the learners. Show the rebates indicated on the given tax table. Explain age related additional rebates.</p>

<p>Medical tax credit:</p> <ul style="list-style-type: none"> • Monthly medical rebate. • Relieving (make less) personal tax; irrespective of the income. • More dependants on medical aid = higher medical tax credit. • Dependants: <ul style="list-style-type: none"> o First dependant = main member. o Second/third dependant etc = other members on your medical aid. 	<p>Explain medical tax credit. Show the medical tax credit on the given tax table. Explain dependants: • The people who are on your medical aid.</p>
<p>INCOME TAX: INDIVIDUALS AND TRUSTS 2016/2017</p>	
<p>Taxable income (R)</p> <p>0 – 188 000</p> <p>188 001 – 293 600</p> <p>293 601 – 406 400</p> <p>406 401 – 550 100</p> <p>550 101 – 701 300</p> <p>701 301 and above</p>	<p>Rate of Tax (R) Tax bracket</p> <p>18% of taxable income</p> <p>33 840 + 26% of taxable income above 188 000</p> <p>61 296 + 31% of taxable income above 293 600</p> <p>96 264 + 36% of taxable income above 406 400</p> <p>147 996 + 39% of taxable income above 550 100</p> <p>206 964 + 41% of taxable income above 701 300</p>
<p>TAX REBATES</p>	
<p>Primary R13 500</p> <p>Secondary (Persons 65 and older) R7 407</p> <p>Tertiary (Persons 75 and older) R2 466</p>	
<p>TAX THRESHOLDS</p>	
<p>AGE TAX</p> <p>Below age 65</p> <p>Age 65 to below 75</p> <p>Age 75 and over</p>	<p>THRESHOLD</p> <p>R75 000</p> <p>R116 150</p> <p>R129 850</p>
<p>MEDICAL TAX CREDIT RATES 2016/2017 YEAR OF ASSESSMENT</p>	
<p>R286 per month for the taxpayer who paid the medical scheme contributions</p>	
<p>R286 per month for the first dependant</p>	
<p>R192 per month for each additional dependant (s)</p>	



TOPIC:	FINANCE												
SECTION	TARIFFS (TELEPHONE)												
OBJECTIVES	<p>Learners need to be able to:</p> <ul style="list-style-type: none"> ○ define the term Tariff ○ Perform calculations involving tariffs. ○ Calculate cost using given tariffs and formulae. ○ Compare two or more different options for a tariff system to determine the most appropriate option for individual with particular needs. ○ Read off break-even values in a graph. ○ Estimate the values of the dependent and independent variables for which the graphs are equal directly from the axes. <p>Draw and interpret graphs of various tariff systems. draw graphs to represent the different options and interpreting the points of intersection and other regions on the graphs in relation to the context</p>												
TERMINOLOGY	<ul style="list-style-type: none"> ➤ Tariff ➤ Two main tariff systems namely prepaid and post-paid. ➤ Subscription fee ➤ Cost per minute. ➤ Minutes / number of calls. ➤ Bill. 												
NOTES	<p><u>WORKED EXAMPLE 1.</u></p> <ol style="list-style-type: none"> 1. Define the term tariff. 2. Ayanda was offered a bursary to study film and multimedia studies at a University in Durban. Covid 19 made it impossible for her to attend normal classes, hence President Ramaphosa urged citizens to stay home during lock down sessions, so she had to study home. Since she did not have her own computer, she needed a cell phone with unlimited web-browsing. <p>The table below illustrates the costs of different cell phone deals from three local cell phone providers.</p> <table border="1" style="width: 100%; border-collapse: collapse;"> <thead> <tr> <th style="width: 33%;">Deal</th> <th style="width: 33%;">Cell phone cost and internet costs</th> <th style="width: 33%;">Calls costs</th> </tr> </thead> <tbody> <tr> <td>Deal 1</td> <td>R2 500 cash for cell phone. R50/ month for internet.</td> <td>R2 per minute.</td> </tr> <tr> <td>Deal 2</td> <td>R250 per month over 24 months; including internet and cell phone.</td> <td>50 free minutes. R2,50 per minute for calls after free minutes .</td> </tr> <tr> <td>Deal 3</td> <td>R400 per month over 24 months; including</td> <td>120 free minutes.</td> </tr> </tbody> </table>	Deal	Cell phone cost and internet costs	Calls costs	Deal 1	R2 500 cash for cell phone. R50/ month for internet.	R2 per minute.	Deal 2	R250 per month over 24 months; including internet and cell phone.	50 free minutes. R2,50 per minute for calls after free minutes .	Deal 3	R400 per month over 24 months; including	120 free minutes.
Deal	Cell phone cost and internet costs	Calls costs											
Deal 1	R2 500 cash for cell phone. R50/ month for internet.	R2 per minute.											
Deal 2	R250 per month over 24 months; including internet and cell phone.	50 free minutes. R2,50 per minute for calls after free minutes .											
Deal 3	R400 per month over 24 months; including	120 free minutes.											

		internet and cell phone.	R1.50 per minute for calls after free minutes.
	<p>a) Determine which deal (for cell phone, internet and calls) is the cheapest over 24 months, if Ayanda makes 2, 5 hours of calls per month. Show all your workings.</p> <p>b) Determine the formula for the total costs per month for:</p> <p style="margin-left: 20px;">i. Deal 1</p> <p style="margin-left: 20px;">ii. Deal 2</p> <p>c) Draw the graph of the total monthly costs for all 3 cell phone deals.</p>		
	<u>SOLUTIONS</u>		
	<p>1. Tariff is a basic amount charged per unit.</p> <p>2. (a) Deal 1 costs = R2 500 + (50 × 24) + (2×210×24 months) [3,5 hours×60=210min]</p> <p style="margin-left: 40px;">R3 700 + (R420×24)</p> <p style="margin-left: 40px;">R3 700 + R10 080</p> <p style="margin-left: 40px;">R13780</p> <p style="margin-left: 40px;">Deal 2 costs = R250×24+R2,50×(210-50 min)× 24 months</p> <p style="margin-left: 40px;">R6000 + (R400×4)</p> <p style="margin-left: 40px;">R6000 + R9 600</p> <p style="margin-left: 40px;">R15 600.</p> <p style="margin-left: 40px;">Deal 3 costs = R400 × 24 + (R1.50 × (210-120 min) ×24 months</p> <p style="margin-left: 40px;">R9 600 + (R135× 24months)</p> <p style="margin-left: 40px;">R9 600 + R3 240</p> <p style="margin-left: 40px;">R12 840</p> <p>~Deal 3 is the cheapest.</p>		
	<p>(i) Deal 1 formula: total cost = R50 + (R2×No. of minutes)</p>		
	<p>(ii) Deal 2 formula : total cost = R250 +[R2.50×(total No. of min – free minutes</p>		
	(c). TOTAL MONTHLY COSTS FOR ALL 3 CELLPHONE DEALS		

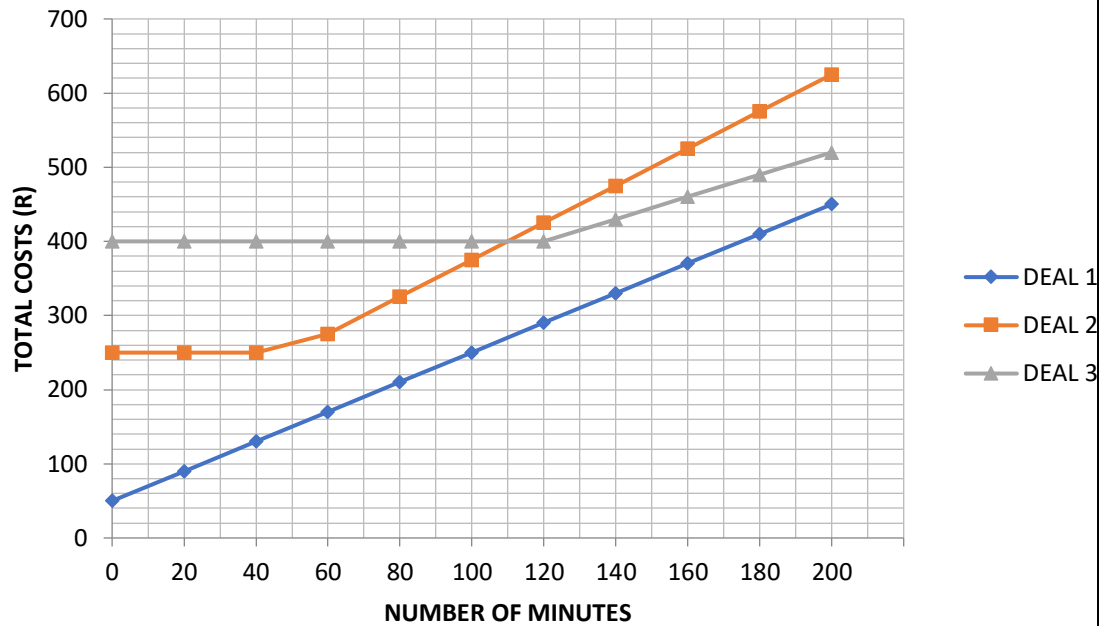

ACTIVITIES

Question 1.

1. Mr Mxhaka is a business man who resides at extension 7. He has a landline telephone which he uses to contact his clients on a daily basis. A service provider has offered him a choice of two different call packages.

CALL PACKAGE 1	CALL PACKAGE 2
<ul style="list-style-type: none"> • Monthly rental : R150 	<ul style="list-style-type: none"> • Monthly rental of R300
<ul style="list-style-type: none"> • First 100 minutes are free 	<ul style="list-style-type: none"> • First 500 minutes are free
<ul style="list-style-type: none"> • Calls cost R0.50 per minute 	<ul style="list-style-type: none"> • Calls cost R0.50 per minute

The total cost for call package 1 is given by the following formula:

$$\text{Total cost(rand)} = \text{R150} + \text{R0.50} \times (\text{number of minutes more than 100})$$

- 1.1. Write down a formula which can be used to calculate the total (in a rand) for CALL PACKAGE 2. (2)
- 1.2. If call package 2 is used, determine the total cost, in rand, if Mr Mxhaka made calls with a total duration of 510 minutes.(4)
- 1.3. Which call package would you recommend Mr Mxhaka to purchase, if he makes 700 minutes worth of calls per month? (2)

EXAMPLES WITH SOLUTIONS

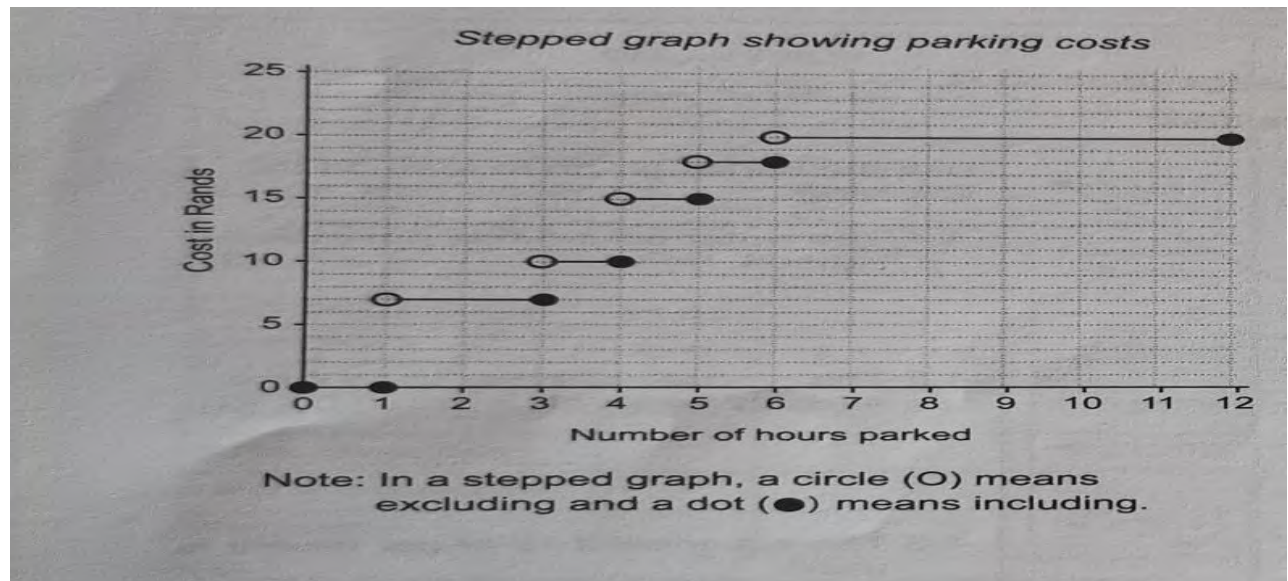

NB: The graph indicates that the more you use, the more you pay

2. The local Municipality Ezweni, has been using the following tariff structure in 2020. Study the Table below and answer the question papers that follow.

TABLE 1: EZWENI MUNICIPALITY WATER TARIFFS STRUCTURE FOR RESIDENTIAL PROPERTIES IN 2019/2020

WATER USAGE	RATES PER LILOLITRE (EXCLUDING 15% VAT)
0 to 6kl	R0
Over 6kl to 12 kl	R19, 01
Over 12kl to 40kl	R25,60
Over 40 kl	R30, 10

Mr Cele who is a resident at EZWENI Local Authority. He used an average of 28 kilolitres of water, in November 2020. Calculate (in rand) that is paid to the Local Municipality, including VAT.

(7)

- $6 \text{ kl} \times R0 = R0$

22kl left

$6\text{kl} \times R19, 01=R114,06$

16kl left

$16\text{kl} \times R25,60 = R409,60$

Total cost including VAT= $(R0 + R114,06 + R409, 60) \times 1.15$

$$= R933,26 \times 1,15$$

$$= R1079,25$$

LEARNERS ACTIVITIES

ACTIVITY 1

Lungelo from Ekwazini Municipality is staying there with his wife and 3 children. He has been billed by the Local Municipality for water used in September 2020. The following table shows the water tariffs for both residents and businesses.

TABLE 1: EKWAZINI MUNICIPALITY WATER TARIFF STRUCTURE FOR RESIDENTS AND BUSINESSES IN 2019/2020

WATER USAGE	TARIFFS PER KILOLITRE FOR RESIDENTS (EXCLUDING 15% VAT)	BUSINESS RATES (EXCLUDING 15% VAT)
0 < kl ≤ 6	FREE	147 ^c (excluding 15 % VAT)
6 < kl ≤ 15	R16, 01	
15 < kl ≤ 38	2800 ^c	
Over 38	R31, 20	

1.1 Define the term tariff (2)

1.2 Lungelo used 36 kl with his family in September 2020. Calculate the Total cost, including VAT of water used. (8)

1.3 Lungelo is also owning a saloon in the nearest Township. He is also charged as per business rate including 15% VAT, for using 25kl of water. Work out the cost of water used in his business.

(4)

[14]

ACTIVITY 2

INKABA community is charged for water usage using the following tariff structure for 2020

TABLE 2: TARIFF STRUCTURE USED BY THE MUNICIPALITY OF INKABA COMMUNITY FOR 2020

Water usage in kl	Tariff (including VAT)
0kl to 4kl	R0, 90
5kl to 10kl	R11, 35
11kl to 20kl	R18, 05

21kl plus	25, 49	
2.1 Mrs Stuart from the INKABA Community was charged an amount of R798,00 including 15% VAT in October 2020. Calculate how many kl of water were used? (7)		

TOPIC: FINANCE	
SECTION: TARIFFS (TRANSPORT)	
LESSON OBJECTIVES	<ul style="list-style-type: none"> ○ Learners must know how to define the term tariff. ○ Perform calculations involving tariffs. ○ Calculate costs using given tariffs and formulae. ○ Compare two or more different options for a tariff system to determine the most appropriate option for individual with particular needs. ○ Read off break-even values in a graph. ○ Estimate the values of the dependent/ independent variable for which the graph are equal directly from the axes. ○ Draw and interpret graphs of various tariff system, draw graph to represent the different options and interpreting the points of intersection and other regions on the graphs in relation to the context
KEY CONCEPTS/ TERMINOLOGY/VO CABULARY	<ul style="list-style-type: none"> ● Tariff ● Consumption rate ● Time (duration and arrival time) ● Cost for single trip and return trips ● Weekly and monthly tickets
INTRODUCTION	
NOTES	
	<p><u>WHAT ARE TARIFFS?</u></p> <ul style="list-style-type: none"> ● Rates charged for services, rendered. <p><u>Consumption rate</u> – rate at which a commodity such as water, electricity or fuel is consumed.</p> <p><u>Stepped tariff structure system</u></p> <p>This system is designed to :</p> <ul style="list-style-type: none"> ● Encourage people to save or not over use services ● Promote fairness

Example of Stepped tariff structure graph

The table below illustrates a stepped tariff structure system for parking costs

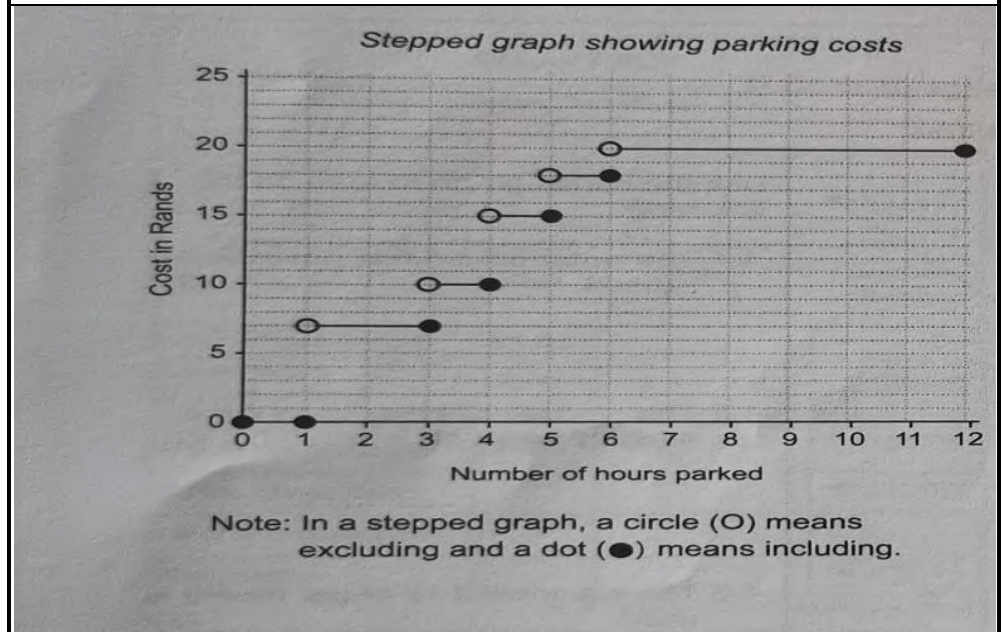

EXAMPLES WITH SOLUTIONS

1. Linda has just been admitted to a new school a bit far from where she stays, she has to decide on the cost effective transport to use to school by comparing the costs of travelling by a bus, taxi or train.



- A bus trip from home to where the school is at costs R20, 40 One way.
- A taxi costs R9,50 half way plus R5,80 for another taxi to take her the whole way
- A return fare by train costs R25.00

1.1 Which mode of transport is the cheapest for a single trip? Show all calculations

SOLUTION

$$\begin{aligned} \text{Bus} &= \text{R}20,40 & \text{Taxi} &= \text{R}9,50 + \text{R}5,80 & \text{Train} &= \text{R}25,00 \\ & & &= \text{R}15,30 & & \end{aligned}$$

1.2 Draw a graph that illustrates the cost per trip, using the 3 different mode of transport, calculate for 5 trip.

SOLUTION

No of trips	<u>1</u>	<u>2</u>	<u>3</u>	<u>4</u>	<u>5</u>
Cost for Bus	R20,40	R40,80	R61.20	R81.60	R102,00
Cost for taxi	R15,30	R30.60	R45.90	R61.20	R76.50
Cost for train	R12,50	R25.00	R37.50	R50,00	R62.50

GRAPH

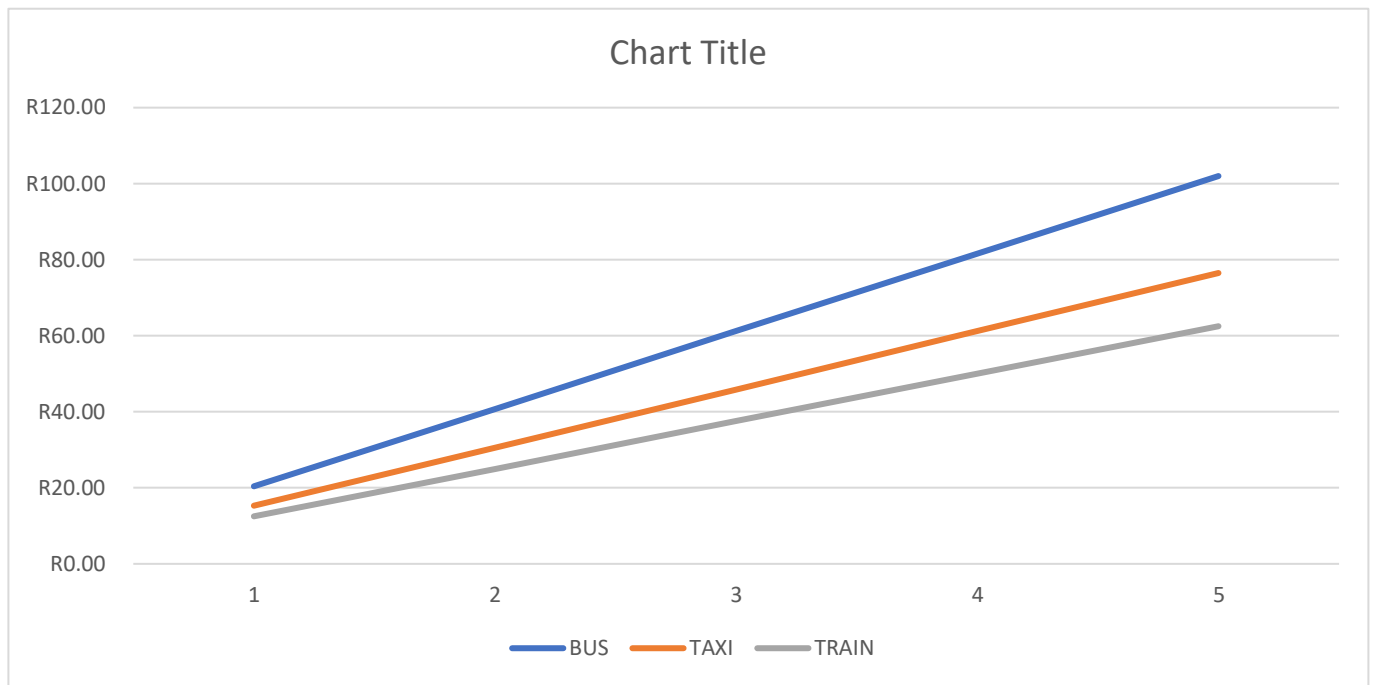

1.3 According to Linda's findings, which mode of transport is the cost effective one and why?

SOLUTION

Train because it is cheaper to travel with

1.4 If Linda attends school 5 times in a week, determine the total amount she's going to pay at the end of the month if she uses the bus as her mode of transport.

SOLUTION

$$\begin{aligned} &R25,00 \times 5 \text{ times} \\ &= R125 \text{ In a week} \times 4 \text{ weeks} \\ &= R500 \end{aligned}$$



ACTIVITIES

1.1 An educator drove 383.5km from Komani to Port Elizabeth. The car used 28,239l of Petrol at a cost of R434,61.

1.1.1 Calculate the petrol price per litre.

(2)

1.1.2 Determine the average distance travelled per litre.

(2)

1.1.3 Calculate the cost in Rand per kilometre travelled.

(2)

1.1.4 Determine the litres of fuel required for a distance of 175 km at the same rate of consumption

(3)

1. Mr and Mrs Bokopane have decided that they need to start money to go on a holiday in December. They decide that the best way to do this is to draw up a budget and work out how much money they are able to save every month for the holiday. They decide to put all the money they have left over after their expenses into their holiday.

Below is a table showing Mr and Mrs Bokopane's budget for the month of June 2020.

MONTHLY INCOME		MONTHLY EXPENDITURE	
Salary after deductions	R23 800	Pension	R1 250
Rent Income	R4350	Medical Aid	R5 600
		Insurance	R2 320

		Rates and Taxes	R1 420
		Water and Refuse	R 340
		Electricity	R1 150
		Car Payment	R2 950
		School Fees	R1 400
		Food	R2 900
		Clothing	R 850
		Petrol	R1 250
		Entertainment	R 900
		Cell phone	R 800
		Maintenance and rental unit	R 750
		Saving (9% of total income)	A
TOTAL	R28 150	Total	B
		Holiday budget	

- 1.1. Calculate A (the amount of savings) that they put away every month.
- 1.2. Calculate the total expenditure of the Bokopane's household, according to the budget.
- 1.3. Mr and Mrs bokopane save for 6 months. Calculate how much they have saved thus far.
- 1.4. The Bokopane family found 2 different accommodation options for their holiday. Use the information below to choose the best accommodation for them. The family decides to stay over for 7 days and they found that the cost of the meals for 4 people will be a minimum of R400. The family packs sandwiches for lunch.

Option 1

Cosy bed and breakfast offers accommodation for R750/day for the entire family; this includes only breakfast.

Option 2

Waterfall hotel offers accommodation at R1400/day for the entire family; this includes all meals and access to many entertainment facilities.

- 1.5. The Bokopane family decides that after the holiday, they would continue to put away the same amount of money and after 5 months they would have a substantial amount of money to put into an interest bearing account at the bank to maximise their savings.
 - 1.5.1. How much will the Bokopane's have to put into the savings account after 5 months?
 - 1.5.2. Calculate how much the Bokopane's will have after 6 months if the bank offers them an interest rate of 9,5 p.a.

TOPIC: Finance

SECTION: Cost price and selling price

OBJECTIVES: Investigate the running of a small business with consideration of the following for the business:

- Income and Expenditure statement
- Budgets
- Break-even analysis.

<ul style="list-style-type: none">• The cost of production, cost price and selling price of an item or service sold/rendered by the business.
TERMINOLOGY:
<ul style="list-style-type: none">• Cost price:• Selling price:• Break-even:• Profit• Income:• Expenditure:
NOTES:
<ul style="list-style-type: none">• Determine the cost of production and/or cost price of an item or service.• Understand the difference between the cost of production and the cost price.• Decide on an appropriate selling price for an item and/or service based on an expected percentage profit.• Investigate the running of a small business.• Determine the break-even values by:<ul style="list-style-type: none">➤ Drawing two graphs on a set of axes and reading off the points of intersection of the graphs➤ Trial and improvement through substitution into two or more equations representing the scenario and/graphs• Understand that the break-even point is always made up of two values• Understand that the meaning of the break-even values is determined by the context in which the break-even values occur.

WORKED EXAMPLES

1. Amukelani grows cacti plants and sells them to the local nursery. He generally sells 20 cacti in a batch for R690 excluding VAT. His costs with VAT per batch include:
Potting soil which is R85, plant pots which costs R120, water which costs R40, labels which costs R62 and transport which costs R58.

1.1 Determine the selling price per cactus including VAT).

- Selling price per cactus excl. VAT = $\frac{690}{20}$ ✓ = R34,50 ✓

$$\begin{aligned} \text{Selling price per cactus incl. VAT} &= \frac{115}{100} \times 34,50 \checkmark \\ &= R39,68 \checkmark \end{aligned}$$

1.2 Determine the cost price per cactus including VAT)

$$\begin{aligned} \text{Total cost price including VAT per batch} &= R85 + R120 + R40 + 62 + 58 \checkmark \\ &= R365,00 \checkmark \end{aligned}$$

$$\begin{aligned} \text{So, Total cost including VAT per cactus} &= \frac{R365}{20} \checkmark \\ &= R18,25 \checkmark \end{aligned}$$

1.3 Calculate Amukelani's profit per cactus.

$$\begin{aligned} \text{Profit} &= \text{Selling price} - \text{Cost price} \\ &= R39,68 - R18,25 \checkmark \\ &= R21,43 \checkmark \end{aligned}$$

1.4 Determine the percentage profit Amukelani makes per cactus.

$$\begin{aligned} \% \text{Profit} &= \frac{\text{profit}}{\text{cost price}} \times 100 \\ &= \frac{R21,43}{R18,25} \checkmark \times 100 \checkmark \\ &= 117,42\% \checkmark \end{aligned}$$

POPULATION: The entire group about which data is collected.

SAMPLE: A collection of people that represent the population.

ORDER (ARRANGE): Sort the data set in:

ASCENDING ORDER: (smallest value to largest value)

DESCENDING ORDER: (largest value to smallest value)

RANGE: The largest data value MINUS the smallest data value.

MEAN (AVERAGE): Add all the data values together and divide the answer by the NUMBER of data values.

Always use the formula: $Mean = \frac{\text{total of data values}}{\text{number of data values}}$

MODE: The piece of data found MOST often.
There can be more than one mode.

MEDIAN: After the set is arranged in size order the MIDDLE-MOST value is the median.

When the set has an UNEVEN number of data values, there is a data value in the middle.

When the set has an EVEN number of data values, the median will be the MEAN of the middle TWO data values.

QUARTILES: Quartiles divide the data into four equal parts.

The **MEDIAN** is also Q_2 , sometimes called the 2nd Quartile.

The **LOWER QUARTILE** Q_1 is the middle data value when looking from the start of the arranged data set to Q_2

Q_1 is also the 25th percentile, sometimes called the 1st Quartile

The **UPPER QUARTILE** Q_3 is the middle value when looking from the median to the last data value.

Q_3 is also the 75th percentile, sometimes called the 3rd percentile.

INTERQUARTILE RANGE: The difference between Q_3 and Q_1 . ($Q_3 - Q_1$)

This section represents the middle 50% of the data set.

1.1 Statistics SA released data that shows the number of marriages per month that took place from 2011 to 2015. Use the table below to answer the questions that follow:

TABLE: Number of marriages per month from 2011 - 2015

	Jan	Feb	Mar	Apr	May	Jun	Jul	Aug	Sep	Oct	Nov	Dec
2011	11 353	11 403	13 802	14 808	10 794	10 254	10 767	10 730	13 883	15 828	15 966	27 676
2012	10 866	11 351	14 359	12 941	10 928	10 466	9 850	10 689	14 272	13 491	14 761	27 138
2013	10 106	10 360	13 873	12 805	10 905	10 218	9 776	11 183	13 455	13 507	15 735	26 719
2014	9 526	10 331	13 203	12 107	10 271	9 384	9 975	10 272	12 245	13 686	14 960	24 892
2015	9 401	10 340	11 795	11 795	10 482	9 086	9 086	9 836	11 977	13 500	13 268	18 343

1.1 Determine the range of the number of marriages for 2013. (3)

1.2 Determine the probability of randomly selecting a month in 2011 with less than 12 000 marriages. (3)

1.3 Mbulelo claims that both median and the mean can be used to represent the data on the number of marriages for 2015. Verify, showing ALL calculations, if Mbulelo's claim is correct. (7)

1.4 Explain why the set of data for 2015 is considered to be bi-modal. (2)

1.5 Calculate the number of marriages in the fourth quarter of 2014, as a percentage to the total number of marriages for 2014. (6)

1.6. Which method of data collection was used to collect the data above, explain your answer (3)

1.7. Is the data given biased or not? Justify your answer. (3)

On 14 February 2012 there was a queue of customers waiting to eat at Danny's Diner, a popular eating place in Matatiele.

The time (in minutes) that 16 of Danny's customers had to wait in the queue is given below:

30	15	45	36	A	40	34	B
B	42	26	32	38	35	41	28

B is a value greater than 20.

- 1.1 The range of the waiting times was 37 minutes and the mean (average) waiting time was 34 minutes.
(a) Calculate the missing value **A**, the longest waiting time. (2)
(b) Hence, calculate the value of **B**. (4)
(c) Hence, determine the median waiting time. (3)
- 1.2 The lower quartile and the upper quartile of the waiting times are 27 minutes and 41,5 minutes respectively.
How many of the 16 customers had to wait in the queue for a shorter time than the lower quartile? (2)
- 1.3 Danny's previous records, for 16 customers on 7 February 2012, showed that the median, range and the mean (average) of the waiting times were 10 minutes, 5 minutes and 10 minutes respectively.
Compare the statistical measures relating to the waiting times on 7 and 14 February and then identify TWO possible reasons to explain the difference in these waiting times. (4)

TOPIC:Data Handling

SECTION:Summarising Data

OBJECTIVES:

The Learners should be able to:

- Analyse data sets using central tendencies and or spread
- Understand the function / purpose of measures of central tendency and spread

TERMINOLOGY

MEAN:- Is the Average of all Scores

MEDIAN:- Is the Middle score

MODE:- Is the score that appears the Most

MINIMUM:- Is the Smallest score

MAXIMUM:- Is the Largest score

RANGE:- Is the difference between the highest score and lowest score

QUARTILE:- Are points that divide the data into quarters

FIRST QUARTILE(Q1):- Is the midpoint of the lower half of the data

SECOND QUARTILE(Q2):- Is the Median

THIRD QUARTILE(Q3):- Is the midpoint of the higher half of the data

INTERQUARTILE RANGE:- Is the difference between the First and Third Quartile

PERCENTILE:- Are points that divide the data into 100 equal parts

OUTLIERS:- Are points that differ significantly from the other data points

NOTES

Each Central tendency help us analyse the given data in different ways

1. Mean

Advantage: The calculation of the mean uses all values in the data so it works best with continuous data.

Disadvantage: it is easily skewed by outliers.

2. Median

Advantage: Outliers or skewed data have little to no effect.

Disadvantage: its value is not dependant on all the values in the data set.

3. Mode

Advantage: Best suited to categorical data

Disadvantage: does not suit continuous data.

When analysing different type of data the following central tendencies are best

1. Mean is best for symmetrical distribution for continuous data

2. Median is best for skewed distribution for continuous data

3. Mode is best for categorical data

Spread also helps us analyse the given data

1. Quartiles

The calculation of the quartiles uses half of the values in the data and works best with continuous data. As a result it is less effected by outliers.

2. Interquartile Range

Tells us about the range of the middle half of the data thus it is not affected by outliers.

WORKED EXAMPLES

QUESTION 1		Marks																						
1.	Use the table below which gives the heights of 10 friends, each measured to the nearest centimetre, to answer the questions that follow: <table border="1" data-bbox="305 443 704 863"> <thead> <tr> <th>Name</th> <th>Height (cm)</th> </tr> </thead> <tbody> <tr><td>Albert</td><td>181</td></tr> <tr><td>Beth</td><td>176</td></tr> <tr><td>Cindy</td><td>154</td></tr> <tr><td>David</td><td>185</td></tr> <tr><td>Emily</td><td>169</td></tr> <tr><td>Frank</td><td>185</td></tr> <tr><td>Gary</td><td>166</td></tr> <tr><td>Helen</td><td>173</td></tr> <tr><td>Ida</td><td>129</td></tr> <tr><td>Jeremy</td><td>168</td></tr> </tbody> </table>	Name	Height (cm)	Albert	181	Beth	176	Cindy	154	David	185	Emily	169	Frank	185	Gary	166	Helen	173	Ida	129	Jeremy	168	(2)
Name	Height (cm)																							
Albert	181																							
Beth	176																							
Cindy	154																							
David	185																							
Emily	169																							
Frank	185																							
Gary	166																							
Helen	173																							
Ida	129																							
Jeremy	168																							
1.1	Calculate the Mean. $\text{Mean} = \frac{1686}{10} = \underline{168}$	3																						
1.2	Calculate Median. 129; 154; 166; 168; 169; 173; 176; 181; 185; 185 $\text{Median} = \frac{169+173}{2}$ $= \underline{171}$	3																						
1.3	Identify the Mode. Mode = <u>185</u>	2																						
1.4	Which central tendency best suited to analyse this data? <u>Median</u> as there is an outlier	2																						
1.5	Calculate the Range. Range = 185 – 129 = <u>56</u>	3																						
1.6	Calculate the first quartile. 129; 154; 166; 168; 169; Q1 = <u>166</u>	2																						
1.7	Calculate the the third quartile. 173; 176; 181; 185; 185 Q3 = <u>181</u>	2																						
1.8	Calculate the Interquartile range. IQR = 181 – 166 = <u>15</u>	3																						
1.9	Who is the outlier? <u>Ida</u> as she is much shorter than the others in the group	2																						

1.10	Calculate the Mean excluding the outlier. $\text{Mean} = \frac{1557}{9}$ $= \underline{173}$	3
1.11	Compare the Mean with the outlier to the Mean without the outlier. The mean without the outlier is closer to the centre of the set of data	2
1.12	Calculate the Range excluding the outlier. $\text{Range} = 185 - 154$ $= \underline{31}$	3
1.13	Compare the Range with the outlier to the Range without the outlier. The range without the outlier is much smaller	2
TOTAL		[32]
ACTIVITIES		
QUESTION 1		Marks
Janet has a shop with Scrapbooking Department and a Toy Department. She kept a record of ages of the customers who visited the two departments on a particular day. Scrapbooking Department: 35 60 46 57 54 34 60 54 56 46 47 67 65 54 45 Toy Department: 5 15 25 7 36 21 70 20 17 6 15 65 9 15		
1.1	Arrange the ages of the customers who visited the toy department in ascending order.	2
1.2	Calculate the range of the ages of the customers who visited the Toy Department	3
1.3	Determine the median of the ages of customers who visited the Scrapbooking Department.	2
1.4	Which set of data has an outliers?	2
1.5	Determine the mean (average) of the ages of customers who visited the Scrapbooking Department.	3
1.6	Name the central tendency best suited to each of the sets of data and explain.	4
TOTAL		[16]

TOPIC:DATA HANDLING	
SECTION:Summarizing Data Percentiles	
OBJECTIVES:	
<ul style="list-style-type: none"> By the end of this lesson, learners will be able to recognize trends at different places in the data to 	
TERMINOLOGY:	
<ul style="list-style-type: none"> Mean median, mode, range and IQR. 	
NOTES:	
In everyday life, percentiles are used to understand values such as test scores, health indicators, and other measurements.	
<i>WORKED EXAMPLES</i>	
QUESTION 1	Marks
	Mrs Long is the high-jump coach at Roseland High School. She records the heights jumped by the five boys in the high-jump team.
1.1	Lerato is one of the members of the team. The following are heights, in metres, of his last 12 jumps: 1,70; 1,68; 1,78; 1,90; 1,74; 1,85; 1,81; 1,95; 1,98; 2,00; 2,02; 1,80 Determine the following:
1.1.1	The median height jumped by Lerato during his last 12 jumps
1.1.2	The height that is his lower quartile (Q1)
1.1.3	The height that is his upper quartile (Q3) (2)
1.1.4	His Interquartile range (IQR), in centimetres, using the formula: Interquartile Range = Upper Quartile – Lower Quartile OR $IQR = Q3 - Q1$.
1.2	The athletes in the high-jump team were told that if their 75th percentile were at 1, 95 m or higher, they would qualify to take part in the inter-high competition.
1.2.1	Which of the heights jumped by Lerato is at his 75th percentile?
1.2.2	The 75th percentiles for the other four members of the team were as follows: Charles 1, 94 m Lebo 1, 80 m Mohamed 1, 95 m Siyabonga 2, and 00 m. Which of the five athletes did NOT qualify to take part in the inter-high competition? Give a reason for your answer.
TOTAL	
[]	

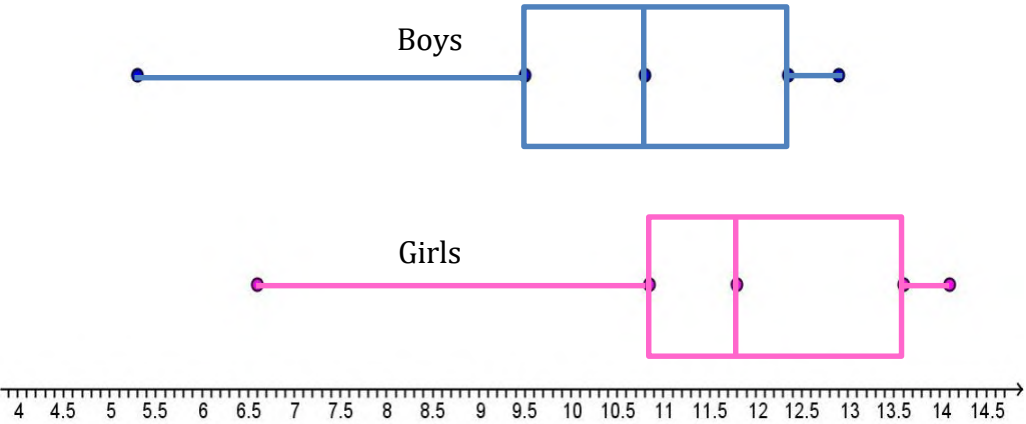
QUESTION 1		Marks
1.1	<p>Given below are the box-and-whisker plots for the girls and boys grade 9 mathematics results for the different provinces. Study them carefully before answering the questions that follow.</p> 	
1.1.1	Which group of students performed better as a whole?	
1.1.2	What was the median mark for both sets of data?	
1.1.3	Is the distance from the whisker to the first quartile the same for boys and girls?	
1.1.4	Do you think the data in both box-and-whisker plots is evenly spread? Give a reason for your answer.	
1.1.5	Give the range of marks for both boys and girls.	
1.1.6	Would gender be considered a categorical or numerical piece of data?	
1.1.7	Would maths marks be considered discrete or continuous data? Give a reason for your answer.	
1.2	Given below is a pie chart which shows the typical South African's monthly household expenses. Study it carefully before answering the questions that follow.	

	<table border="1"> <caption>Household Expenses Data</caption> <thead> <tr> <th>Category</th> <th>Percentage</th> </tr> </thead> <tbody> <tr> <td>Housing, water, electricity, gas and other fuels</td> <td>32,0%</td> </tr> <tr> <td>Transport</td> <td>17,1%</td> </tr> <tr> <td>Food and non-alcoholic beverages</td> <td>12,8%</td> </tr> <tr> <td>Miscellaneous goods and services</td> <td>14,7%</td> </tr> <tr> <td>Furnishings, household equipment and routine maintenance of the dwelling</td> <td>5,1%</td> </tr> <tr> <td>Clothing and footwear</td> <td>3,0%</td> </tr> <tr> <td>Recreation and culture</td> <td>3,0%</td> </tr> <tr> <td>Communication</td> <td>2,8%</td> </tr> <tr> <td>Education</td> <td>2,7%</td> </tr> <tr> <td>Restaurants and hotels</td> <td>2,4%</td> </tr> <tr> <td>Health</td> <td>1,4%</td> </tr> <tr> <td>Alcoholic beverages and tobacco</td> <td>1,1%</td> </tr> </tbody> </table>	Category	Percentage	Housing, water, electricity, gas and other fuels	32,0%	Transport	17,1%	Food and non-alcoholic beverages	12,8%	Miscellaneous goods and services	14,7%	Furnishings, household equipment and routine maintenance of the dwelling	5,1%	Clothing and footwear	3,0%	Recreation and culture	3,0%	Communication	2,8%	Education	2,7%	Restaurants and hotels	2,4%	Health	1,4%	Alcoholic beverages and tobacco	1,1%	
Category	Percentage																											
Housing, water, electricity, gas and other fuels	32,0%																											
Transport	17,1%																											
Food and non-alcoholic beverages	12,8%																											
Miscellaneous goods and services	14,7%																											
Furnishings, household equipment and routine maintenance of the dwelling	5,1%																											
Clothing and footwear	3,0%																											
Recreation and culture	3,0%																											
Communication	2,8%																											
Education	2,7%																											
Restaurants and hotels	2,4%																											
Health	1,4%																											
Alcoholic beverages and tobacco	1,1%																											
1.2.1	Which household expense uses the most monthly income in a household?																											
1.2.2	<p>If a household has a R25 000 monthly income, how much will they spend on</p> <ul style="list-style-type: none"> i) Food and non-alcoholic beverages? ii) Education? iii) Transport? 																											
1.2.3	If a household spends R1300 on housing, water, electricity, gas and other fuels, how much is their total monthly household income?																											
1.2.4	Do you think every household spends 3% on clothing and footwear every month? Give a reason for your answer.																											
1.2.5	How do you think the data used to generate this pie chart was collected?																											
1.2.6	If you had to set up a survey for this data, what kinds of questions would you use? For example, multiple choice questions, open-ended questions and so on.																											

1.3

Body Mass Index (BMI) is a number calculated from a person’s mass and height. BMI number is plotted on the CDC BMI-for-age growth charts (for either male or female) to obtain a percentile ranking. BMI-for-age weight status categories and the corresponding percentiles are shown in the following table.

WEIGHT STATUS CATEGORY	PERCENTILE RANGE
Underweight	Less than the 5th percentile
Healthy weight	5th percentile to less than the 85th percentile
At risk of overweight	85th percentile to less than the 95th percentile
Overweight	Equal to or greater than the 95th percentile

2 to 20 years: Boys
Body mass index-for-age percentiles

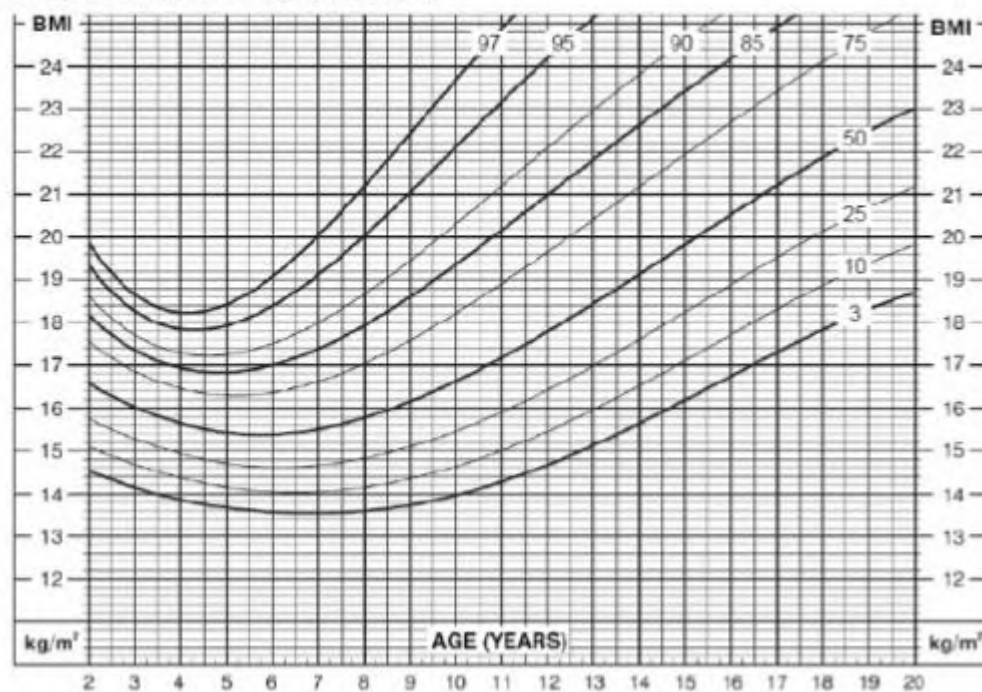

1.3.1

At what percentile would an 8 year old with a BMI of 17 be?

1.3.2

What is the BMI of a 5-year-old boy if his BMI places him at the 90th percentile?

1.3.3

Within what range can a 10-year-old boy BMI be if his weight is considered healthy?

1.4

BMI is calculated using the formula: $BMI = \frac{weight}{(height)^2}$

1.4.1

What is the weight status of an 18-year-old boy who is 1,86m tall and weighs 90kg?

1.4.2

How heavy would a 16-year-old boy be if he is 1,65m tall and his BMI is at the 50th percentile?

TOPIC:DATA COLLECTION		
SECTION:DATA COLLECTION AND METHODS		
OBJECTIVES:		
LEARNER SHOULD BE ABLE TO:		
<ul style="list-style-type: none"> • Construct tally table • Read information in the graph and frequency table • Construct frequency table from general arranged data. • Draw graphs from given data. • Understand intervals between the given data • Understand terminology 		
TERMINOLOGY		
<ul style="list-style-type: none"> • Histogram: 90 degree using adjacent bars to show frequency (horizontal and vertical). • Data: information, series of observation measurement, fact, and recording information for purpose of statistics • Frequency: the number of times the data value is recorded. • Group: put into classes/ sort/ arrange/ organise 		
NOTES		
<ul style="list-style-type: none"> • Learner should be able to construct the frequency tables from the arranged data. • Learners should be able to arrange data in ascending order. • Learners should be able to classify data by intervals • Learners should be able to draw a graph from the given data. 		
WORKED EXAMPLES		
QUESTION 1		Marks
1.1	The histogram for a frequency distribution is given below:	

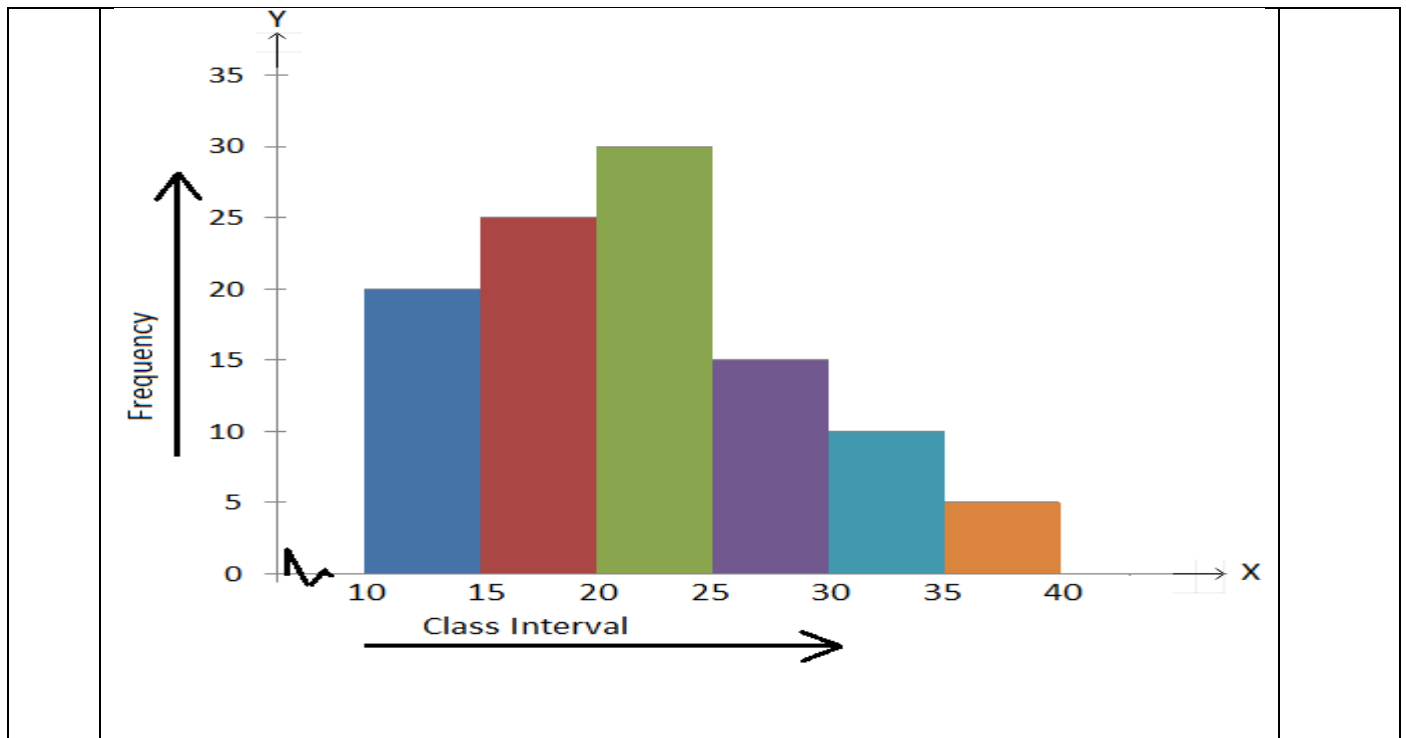

1.1.1	What is the frequency of the class interval 15 – 20?	(2)
1.1.2	What is the class intervals having the greatest frequency?	(2)
1.1.3	What is the cumulative frequency of the class interval 25 – 30?	(2)
1.1.4	Construct a short frequency table of the distribution.	(8)
	TOTAL	[20]
	<i>ACTIVITIES</i>	
	QUESTION 1	Marks
1.1	Answer the following question:	

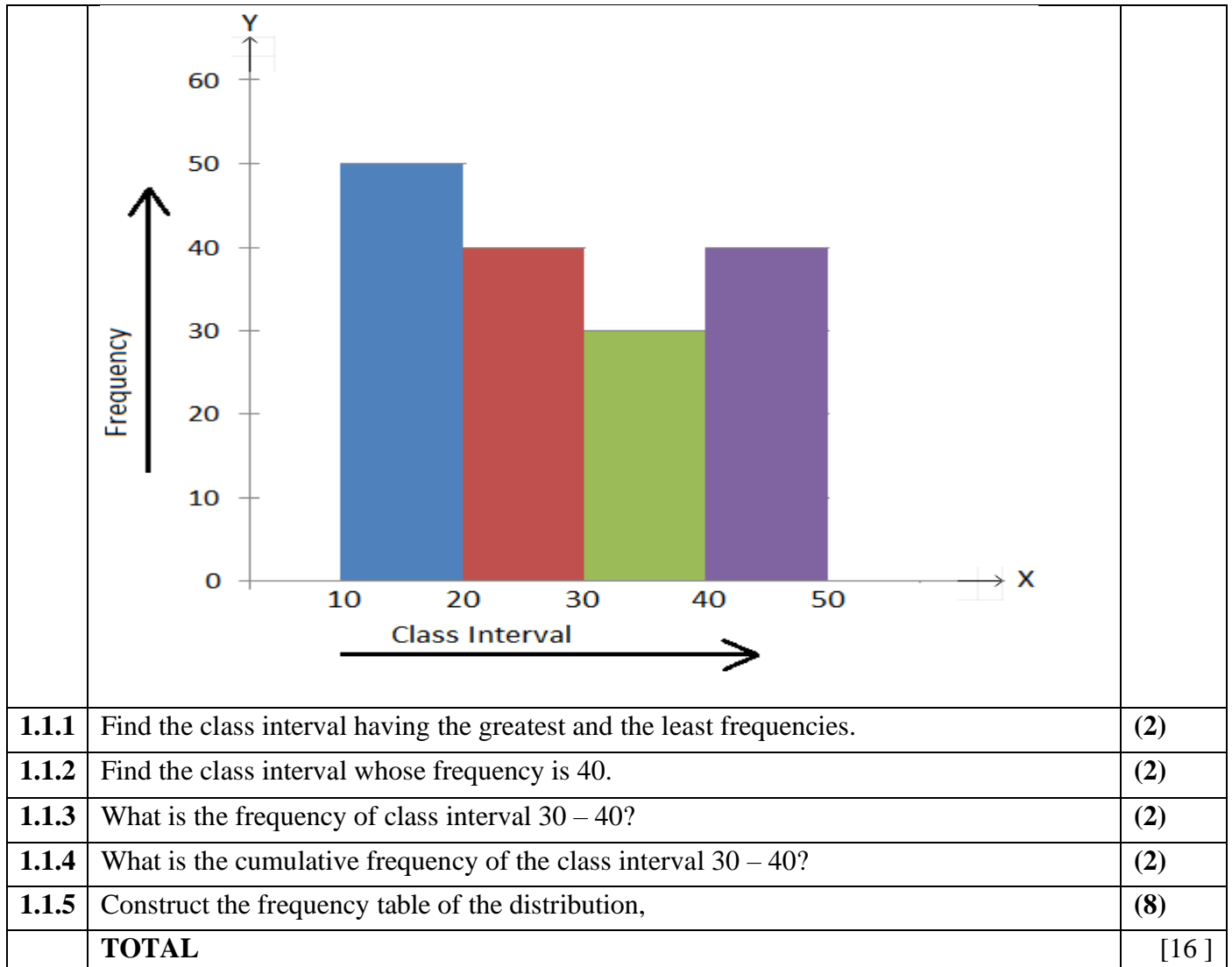

1.1.1	Find the class interval having the greatest and the least frequencies.	(2)
1.1.2	Find the class interval whose frequency is 40.	(2)
1.1.3	What is the frequency of class interval 30 – 40?	(2)
1.1.4	What is the cumulative frequency of the class interval 30 – 40?	(2)
1.1.5	Construct the frequency table of the distribution,	(8)
	TOTAL	[16]

TOPIC: Data Handling

SECTION: Interpreting Data

OBJECTIVES

You should be able to:

- Identify and describe trends.
- Compare different representations of multiple sets of data and explain the differences.
- Identify and describe sources of bias.
- Answer questions under investigation.
- Identify and describe any misleading representations and data summaries.
- Develop apposing arguments

TERMINOLOGY

- **Bias** is an error in the way survey is designed/data is presented that will cause the data to be unreliable **OR** to favour one or unfairness of the survey/presentation.
- **Unbiased** –means fair, unprejudiced and neutral.
- **Trend** is a pathway or the behaviour pattern shown by the data set or a graph.

NOTES

When interpreting and analyzing data, it is important to take the following into account:

- Using percentage to represent data values in a table or graph is useful for comparing relationships in size, but does not reveal the size of the categories clearly.
- Using actual values to represent data values in a table or graph shows the population/sample size clearly, but is often not useful in showing the relationship between the categories clearly.
- When comparing different categories of data, if there is an unequal number of data items in each category, then the use of actual values or percentages to represent the data will affect the impression created by the data.
- The choice of scale and/or the point of which the axes cross impact on the impression created by the graph.
- Tables of the contain more information than graphs, but trends are not easy to observe.

REMEMBER

The interpreting of data is important during the statistical cycle as a whole. Continuously ask questions about the following:

- The size of the sample.
- The representivity of the sample.
- The methods used for collecting data.
- The neutrality of the data collecting process.

- Whether the data collected was fact or opinion.
- The way in which de data was sorted and/or grouped.
- The sizes of the groups used in grouping the data.
- Types of measure to determine the average of the data.
- The spread (range) of the data and what the spread suggests about the data.
- The way the data was represented and why.

WORKED EXAMPLES

QUESTION 1

Marks

1. The graph below shows the population of Cape Town in the year 2009. Use this graph and answer the questions that follows.

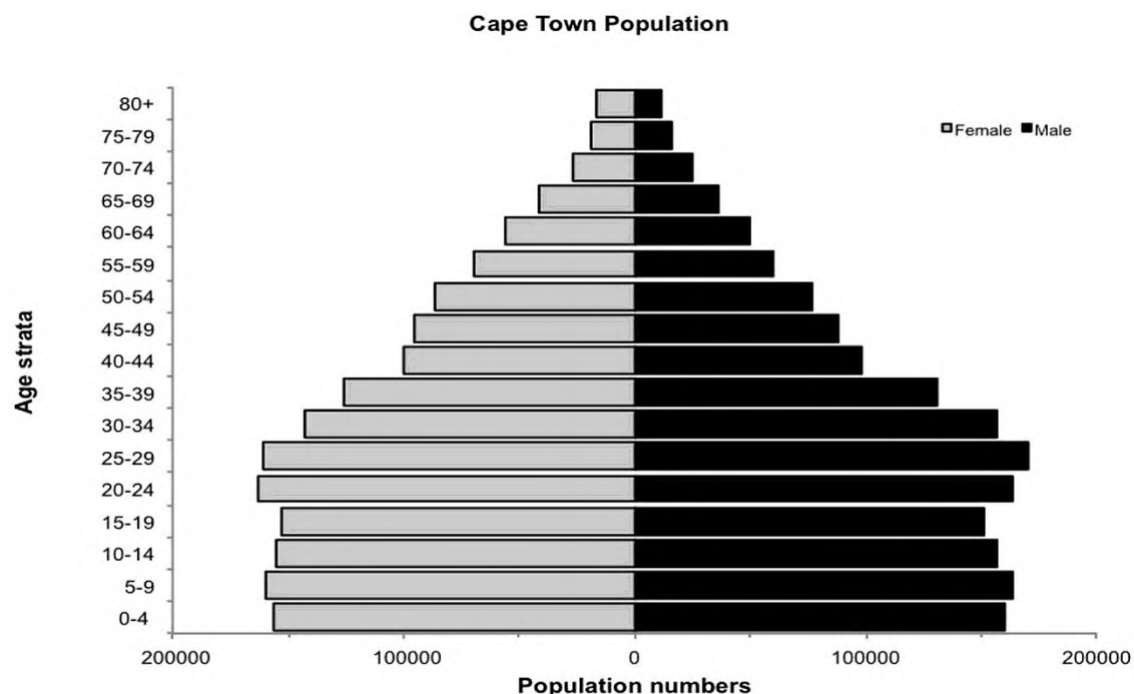

1.1	Describe the trend in the population from birth to 19 years of age in both male and females. <ul style="list-style-type: none"> • In both males and females, the population increases in the 5-9 year age group. • Then there is a gradual decrease from the ages of 10-19 years of age. 	2
1.2	Explain possible reasons for this trend described in 1.1. <ul style="list-style-type: none"> • In the year 2009 less babies were born, than the previous years. • Infants and toddlers (4 years of age) have weaker immune systems and are more prone to fatal childhood diseases. • Between the ages 10-19 most individuals are entering a higher level of schooling, they might become a victim of gang violence (accidents/sickness), or simply move away due to social/economic circumstances. 	3
1.3	Why do you think there are a sudden increase in the population group of the ages 20-24? <ul style="list-style-type: none"> • Cape Town is a popular destination for students and young working individuals. 	2
1.4	Describe the trend in the population from the ages 25 and up. Give a possible reason for this trend. <ul style="list-style-type: none"> • From the ages of 25 and up, the population of Cape Town is gradually decreasing. Possible reasons for this might be relocation due to the high living cost in CT, and shortage of work. Fatalities also contributes to the decrease of the population. 	2
TOTAL		[9]
QUESTION 2		Marks

2 Below are three graphs, showing the U.S age distribution in the years 1970, 2000 and 2030. Use these graphs and answer the questions that follow.

(a) Bars for separate age groups

Year	19 and under (millions)	20-64 years (millions)	Over 65 (millions)
1970	77.2	107.7	20.1
2000	78.4	162.2	34.8
2030	92.6	188.2	70.3

(b) Bars show total population divided into age groups

Year	19 and under (millions)	20-64 years (millions)	Over 65 (millions)
1970	77.2	107.7	20.1
2000	78.4	162.2	34.8
2030	92.6	188.2	70.3

(c) Bars show total population divided into percentages

Year	19 and under (%)	20-64 years (%)	Over 65 (%)
1970	37.7	52.5	9.8
2000	28.5	58.9	12.6
2030	26.4	53.6	20.0

[Source: <https://courses.lumenlearning.com/economics2e-demo/chapter/types-of-graphs/>]

2.1 Which graph, A or B, better represents the trends in each age group?
Explain your answer.

- Graph A will be better, as each age group is already clearly shown.

2

2.2 Which graph, A or B, better represents the trends in the population as a whole?
Explain your answer.

- Graph B will be better, as the total population growth is clearly indicated in every year given

2

2.3 Explain why graph C can cause bias/confusion when viewed individually.

- At first glance it seems that there has been no population growth. The numbers in the bars can also be misinterpreted if the labels have not been observed.

2

TOTAL

[6]

QUESTION 3

Marks

3 Below in figure 2, is a summary of two salespeople monthly targets in the year 2019. Use these diagrams to answer the questions below.

Figure 2. Carl's and Angela's box and whisker plots

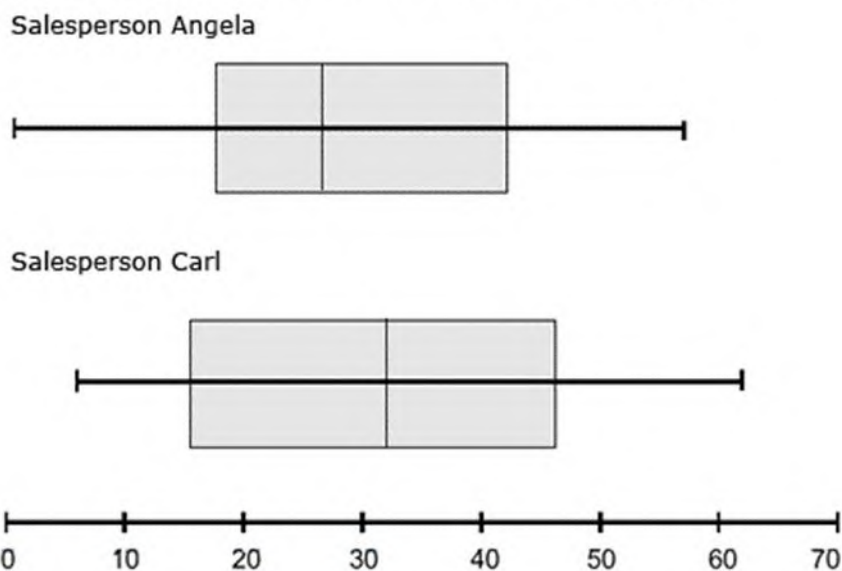

3.1

Is it possible to calculate the mean of each person's monthly targets using the diagram only?

- It is impossible to calculate the mean, as you need a some of the total monthly targets.

2

3.2

Angela believes she had a better year in terms of sales. Validate her belief by using the 5-point summery given on the diagrams.

	Angela	Carl
Min :	2	5
Q2	18	16
Medi an	26	32
Q3	42	46
Max:	58	62

- Angela's minimum and maximum are less than Carl's.
- Angela's spread ($58-2=56$) is similar to Carl's ($62-5=57$).
- Angela's IQR ($42-17=25$) is less than Carl's ($46-16=30$).
- Although the spread and IQR are similar, if you look at the top 50% of the data you will see that Carl sold 32+ items in 50% (6months) of the year.
- Angela only managed to sell 26+ items in 50% of the year.
- It is clear that Angela is incorrect in her assumption, and Carl had a better year in terms of sales.

5

TOTAL

ACTIVITIES

[7]

ACTIVITY 1

Two grade 12 Mathematical Literacy learners in MrMadiba class compared their SBA marks combined with their informal assessment to decide who performed better.

The summary of their performance is represented by box and whisker plot below

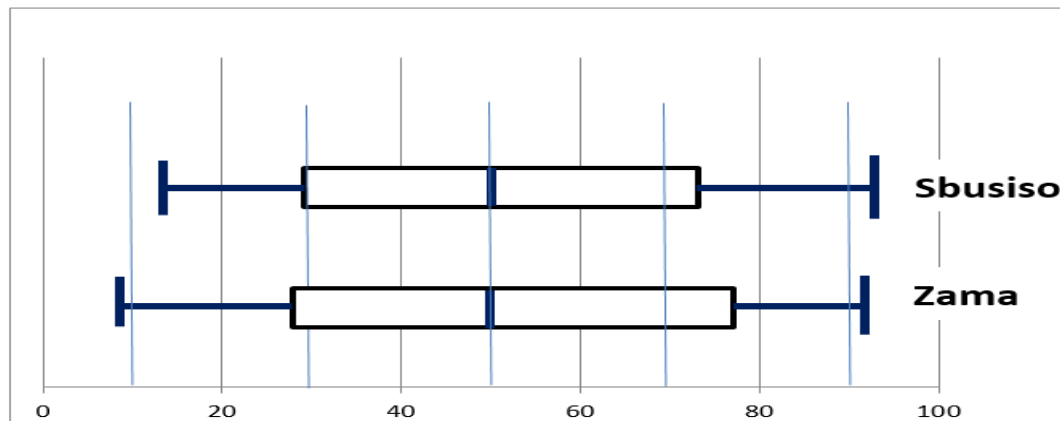

The arranged percentage marks of Zama are given below:

9 14 14 19 21 23 33 35 37 37 38 A
 50 56 57 59 B 75 75 77 78 80 81 92

1.1	Calculate the missing value of A and calculate value of B, if the mean percentage mark of Zama is 49	5
1.2	1.2 Explain which learners performed better in the tests if both the medians and interquartile range are compared.	5

[12]

ACTIVITY 2

The box-and-whisker plots below represents the ages of people living in TWO residential flats. Study it and answer the questions that follow:

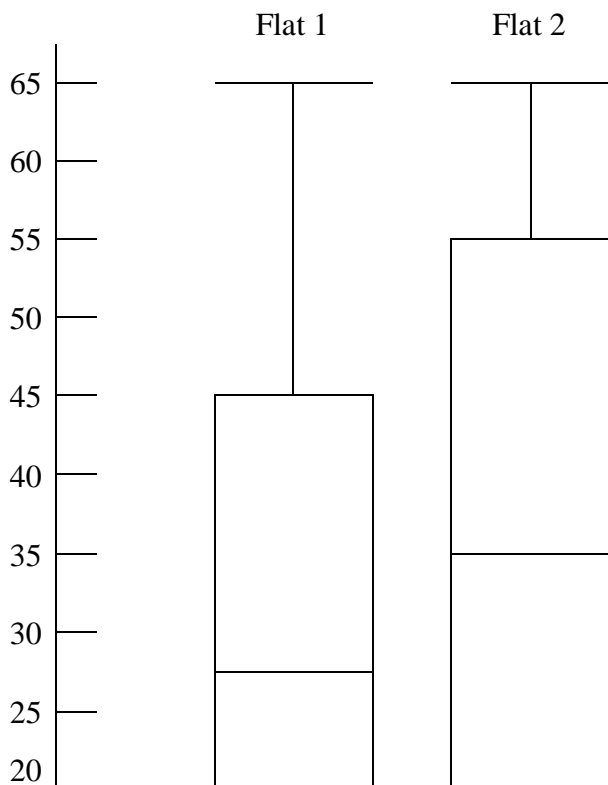

	<p>Flat 1</p> <table border="1"> <tr><td>15</td><td>17</td><td>18</td><td>20</td></tr> <tr><td>B</td><td>23</td><td>23</td><td>24</td></tr> <tr><td>25</td><td>A</td><td>34</td><td>37</td></tr> <tr><td>40</td><td>45</td><td>46</td><td>46</td></tr> <tr><td>48</td><td>65</td><td></td><td></td></tr> </table>	15	17	18	20	B	23	23	24	25	A	34	37	40	45	46	46	48	65			<p>Flat 2</p> <table border="1"> <tr><td>15</td><td>17</td><td>19</td><td>20</td><td>20</td></tr> <tr><td>23</td><td>24</td><td>25</td><td>29</td><td>30</td></tr> <tr><td>30</td><td>32</td><td>33</td><td>33</td><td>33</td></tr> <tr><td>37</td><td>40</td><td>43</td><td>43</td><td>47</td></tr> <tr><td>51</td><td>53</td><td>55</td><td>56</td><td>58</td></tr> <tr><td>60</td><td>61</td><td>61</td><td>62</td><td>65</td></tr> </table>	15	17	19	20	20	23	24	25	29	30	30	32	33	33	33	37	40	43	43	47	51	53	55	56	58	60	61	61	62	65
15	17	18	20																																																	
B	23	23	24																																																	
25	A	34	37																																																	
40	45	46	46																																																	
48	65																																																			
15	17	19	20	20																																																
23	24	25	29	30																																																
30	32	33	33	33																																																
37	40	43	43	47																																																
51	53	55	56	58																																																
60	61	61	62	65																																																
2.1	Considering the information above, what would you see as an outlier? How does this outlier affects your interpretation of the data?	3																																																		
2.2	The median of Flat 1 is 27.5 and the average is 32. Determine the missing values A and B.	6																																																		
2.3	Explain where a mistake was made with the drawing of the box-and-whisker plot of Flat 2	2																																																		

[12]

ACTIVITY 3

The adults generally do not grow taller after a certain age. The situation is different with children. Most children grow taller all the time but that growth does not always happen consistently. In some months a child may grow very fast, while in other months he or she hardly grows at all. For this reason, it is not possible to use a single formula to determine the weight status of all children. Rather, determine the weight status of a child requires a condition of Body Mass index (BMI) and growth charts. A BMI – for – age growth chart is given below showing the relationship between the ages of boys from 2 to 20 years and possible BMI values.

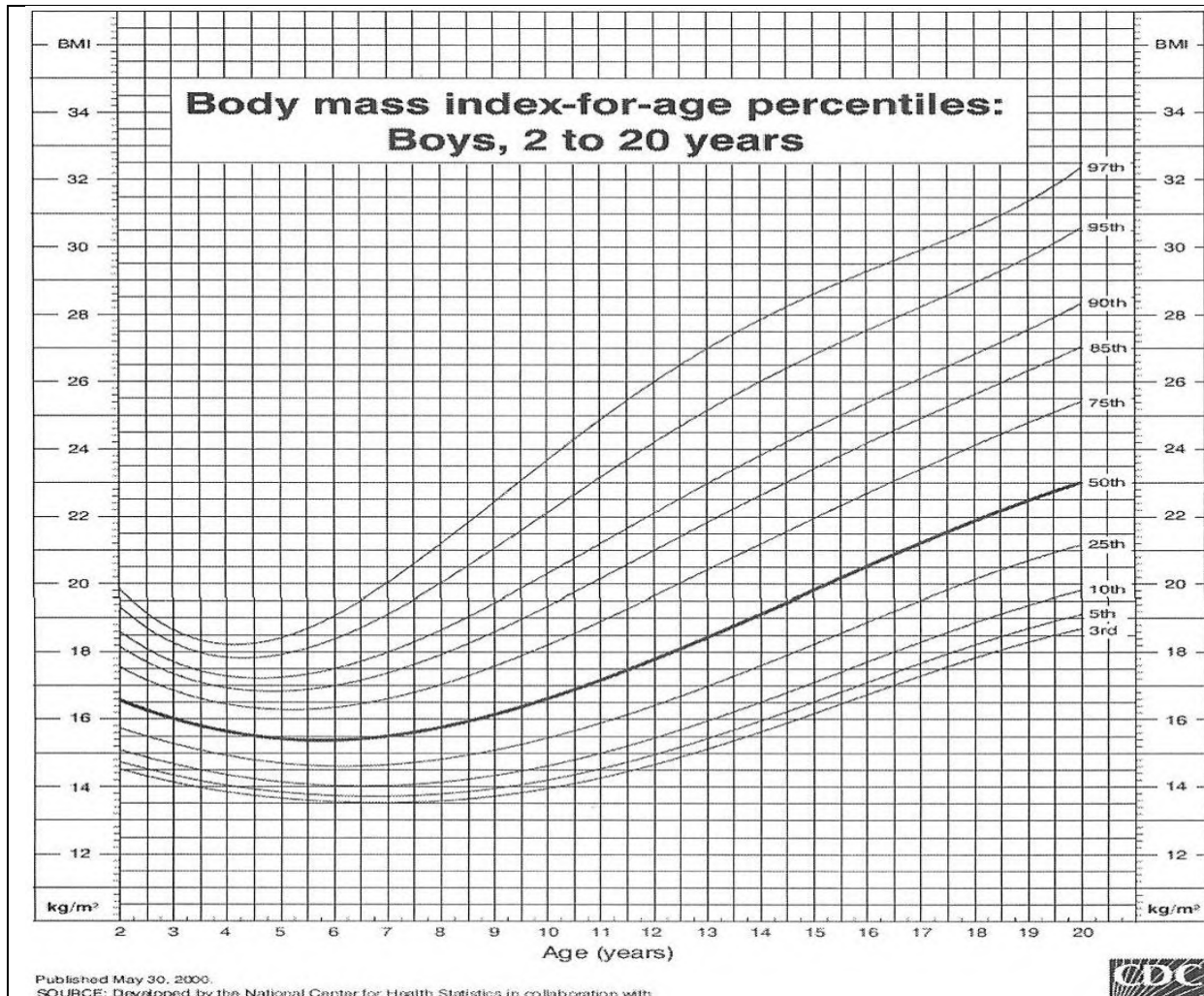

Body Mass Index (BMI) is a number calculated from child’s weight and height. BMI number is plotted on the CDC BMI – for – age growth charts (for either girls or boys) to obtain a percentile ranking. BMI – for – age weight status categories and the corresponding percentile are shown in the following table.

Weight status categories	Percentile range
Underweight	Less than 5 th percentile
Healthy weight	5 th percentile to less than the 85 th percentile
At risk of overweight	85 th to less than the 95 th percentile
Overweight	Equal to or greater than the 95 th percentile

Grace has three children, 16 –year old boy, 13 – year old boy and a 9 year old girl.

3.1	Determine a possible advice that a medical practitioner might give to a 16 year old boy with a BMI value of 28,5kg/m ² .	3
3.2	A 13-year-old boy weighs 55kg and he is 1,45m tall. Determine the weight (in kg) that the should lose to be considered as ‘healthy weight status’. Hint: $BMI = \frac{Weight\ (in\ kg)}{(Height\ in\ m)^2}$	7

TOPIC: DATA HANDLING

SECTION: REPRESENTATION OF DATA

OBJECTIVES: • Represent two sets of data using a variety of graphs.

• Understanding that certain graphs are more appropriate depending on the scenario/context

TERMINOLOGY

Multiple set of data, difference between trend & patterns, categorical and numerical data, discrete and continuous data

NOTES

SCATTER PLOTS: A scatter plot is the most useful graph for studying the relationship/correlation

• **positive correlation:** points show an increasing straight line

• **negative correlation:** points show a decreasing straight line

• **no correlation:** points are scattered randomly without any noticeable pattern.

WORKED EXAMPLES

Marks

EXAMPLES WITH SOLUTIONS

1. The line chart below shows the proportion of people of each sex in each age group that were married in 2001. To answer the questions that follow, you may need to refer to either of the charts, or both.

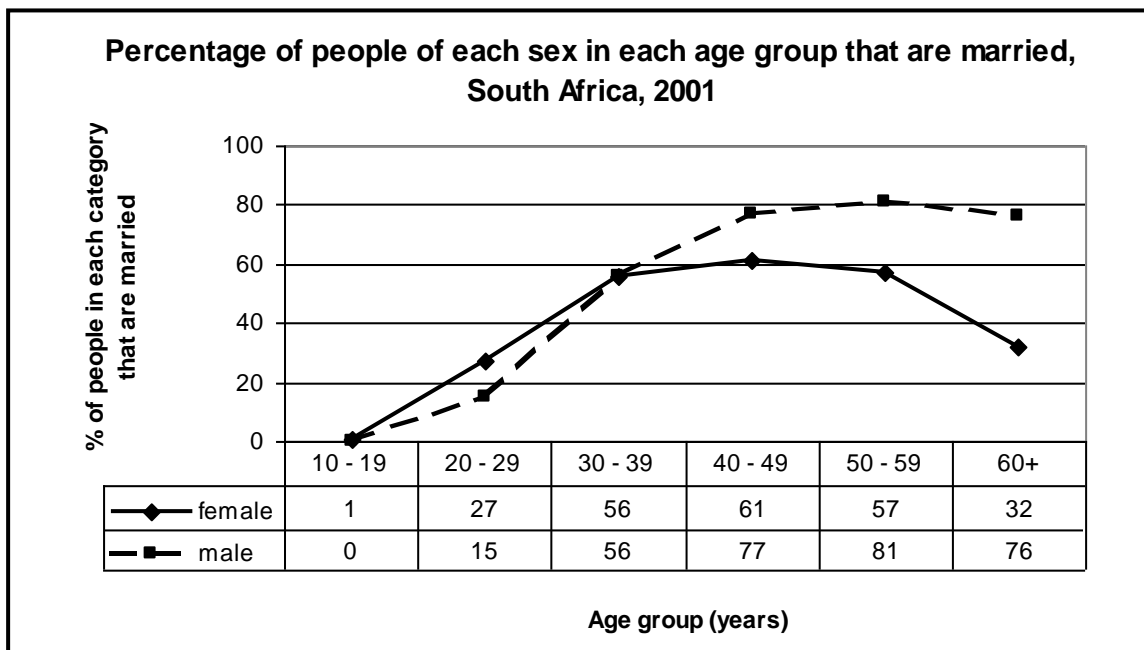

Source: data from 'Women and men in South Africa. Five years on'. Statistics South Africa, 2002

1.1 What percentage of all 30–39 year olds were married?

(2)

1.2 Approximately what *number* of people were married in the 30–39-year age group?

(3)

1.3 Compare the figures for people over 60 years old.

a) What proportion of women above the age of 60 years was married?

(2)

b) What proportion of men above the age of 60 years was married?

(2)

c) Explain why there is such a big difference between these two proportions.

(2)

SUGGESTED SOLUTION

1.1 56% of 30–39 year olds were married. ✓✓

(2)

1.2 There were 6,4 million 30–39 year olds. (See question 4.5 above.)

56% of 6,4 million ✓ $\approx 6,4 \times 0,56$ ✓ $\approx 3,6$ million married 30–39 year olds ✓

(3)

1.3 a) 32% of women above the age of 60 years were married. ✓✓

(2)

b) 76% of men above the age of 60 years were married. ✓✓

(2)

c) The difference in proportion is because men tend to die before their wives do. ✓✓

d) Many women over 60 years are widows. ✓✓

(2)

TOTAL (20)

[5]

ACTIVITIES
QUESTION 1

Miera's mother insists that she must eat as much fruit and vegetables as possible to stay healthy. Miera's favourite fruit is apples and her mother buys a 2 kg bag every two weeks. Being a Mathematical Literacy teacher, Miera's mom investigated the sizes of apples in the 2kg bags that she bought over 14 weeks. Her findings are captured in the following table:

Number of apples in bag	20	16	18	14	10	15	13
Median mass of apples in gram	72	105	110	125	192	142	174

1.1. What do we call the data as shown in the table? Give a reason for your answer. (2)

1.1. A scatter plot drawn for the data in the table looks as follows: (2)

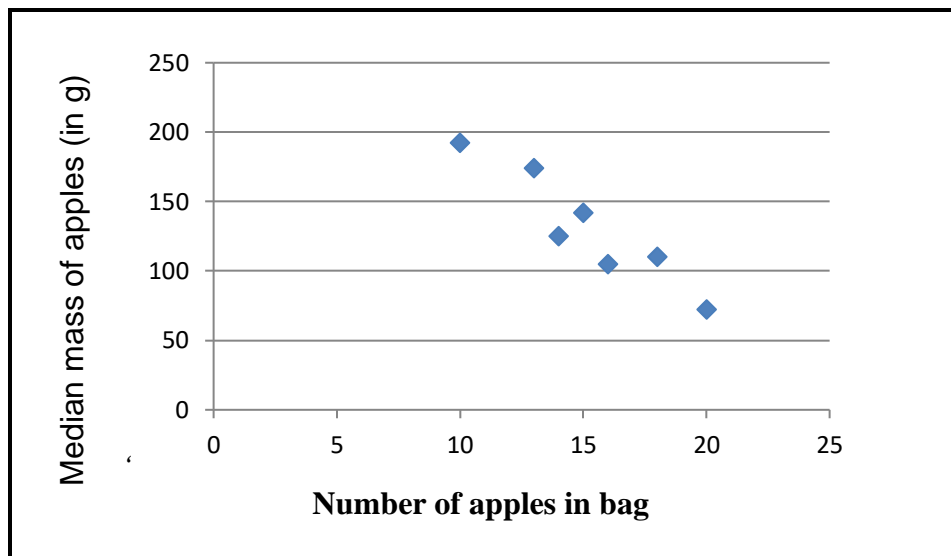

Judge the following statement and indicate whether the statement is TRUE or FALSE. Give a reason for your answer.

The smallest apple in the bag has the biggest median mass of all the apples in the bag. (3)

(5)

TOPIC: FINANCE

SECTION: INTEREST

OBJECTIVES: At the end of the lesson learners must be able to do hire-purchase agreements and loans(eg personal, car, house)

TERMINOLOGY

SALE PRICE	The stated price of the item to be purchased (e.g. sale price of a house, cash price of a car, etc.) e.g. R895 000,00 price of a house
DEPOSIT	An amount that must be paid upfront before the loan is guaranteed. It is often stipulated as a percentage of the loan amount. Example: 15% of R895 000 = $15 \div 100 \times R895\ 000 = R132\ 450,00$
LOAN AMOUNT	The actual amount owed to the bank or loan agent. Loan Amount = Sale Price – Deposit Example: Loan Amount = R895 000,00 – R132 450,00 = R760 750,00
INTEREST RATE	The percentage of the loan amount that will be charged as a ‘fee’ for borrowing the money. It is calculated on the balance owed. e.g. 11,0% p.a. However, interest is worked out on a monthly basis, so the monthly rate = $11,0\% \div 12 = 0,916666\%$ per month.
INTEREST	The amount paid for loaning the money. Calculated on the amount owed at the end of each month. e.g. First month = $R760\ 750,00 \times 0,916666\% = R6\ 973,54$ (This calculation is performed every month on the balance in the account. As it changes so will the interest charged.)
LOAN TERM	The amount of time a person has to pay back the loan (e.g. 5 or 6 years for a car or 15 or 20 years for a house). Also known as the ‘life of the loan’. e.g. 20 years
MONTHLY REPAYMENTS	The amount of money that must be paid back to the bank or loan agent every month. A table of values is used to calculate the monthly repayment according to the following method: $= \text{loan amount} \div 1\ 000 \times \text{factor}$ The factor is obtained from a given table of values
REAL COST	The total amount that will be paid for the loan over the whole life of the loan. Real cost = Monthly repayment amount \times number of repayments made Answer: Real Cost = $R7\ 850,94 \times (20\ \text{years} \times 12\ \text{months per year}) = R1\ 884\ 225,60$

NOTES

WORKED EXAMPLES

--

Mr Siven Pillay is a teacher at Cool Air Secondary, he received his May bank statement from his bank. Table 2 below shows the part of his statement from 1 May 2020 to the 25 May 2020.

Study Table 1 below and answer the questions that follow

TABLE 1: Savings Account Bank Statement

Date	Transaction	Debit	Credit	Closing Balance
01 May 2020	Balance brought forward			-1200
01 May 2020	Interest	12		-1212
10 May 2020	Deposit		1500	A
15 May 2020	Salary		21 500	21 788
16 May 2020	Cash withdrawal	B		19 288
25 May 2020	Car Instalment	5 550		13 738

NB: Interest on overdraft: 10% calculated per day

1.1 Explain the minus sign in front of R1200?

1.2 Write down the interest rate charged on overdue accounts.

1.3 Determine the value of A and B.

Solutions

1.1 This is an overdraft. Funds used up in your account and you are using borrowed funds. This is reflected as a negative balance.

1.2 10%

1.3 $A = 1500 - 1212$

= R288

$B = R21\ 788 - R19\ 288$

= R2 500

LEARNER ACTIVITY

QUESTION 1 [10]

Marks

1. Mr Phungula wants to buy a TV. Games stores are having a Black Friday sale and all Tv's are going on special. The cash price of 102cm TV is R13 999. The deposit is 15%. Balance of the money is calculated at 25%pa interest for two years.

1.1 Calculate the Deposit amount.

2

1.2 Calculate the Principal amount that he will borrow .

2

1.3	Calculate the monthly instalments.	6																														
TOTAL		[10]																														
<p>QUESTION 2 [9]</p> 		Marks																														
2.	<p>Mr Siven Pillay is considering taking a loan. The table below is used to calculate his monthly repayments.</p> <table border="1" data-bbox="256 531 1273 940"> <thead> <tr> <th data-bbox="256 531 505 642">Loan Repayment Loan term</th> <th data-bbox="505 531 651 642">12 months</th> <th data-bbox="651 531 797 642">24 months</th> <th data-bbox="797 531 943 642">36 months</th> <th data-bbox="943 531 1089 642">48 months</th> <th data-bbox="1089 531 1273 642">60 months</th> </tr> </thead> <tbody> <tr> <td data-bbox="256 642 505 716">Loan amount</td> <td data-bbox="505 642 651 716">R10 000</td> <td data-bbox="651 642 797 716">R50 000</td> <td data-bbox="797 642 943 716">R100 000</td> <td data-bbox="943 642 1089 716">R150 000</td> <td data-bbox="1089 642 1273 716">R200 000</td> </tr> <tr> <td data-bbox="256 716 505 789">Monthly repayment</td> <td data-bbox="505 716 651 789">R1 200</td> <td data-bbox="651 716 797 789">R3980</td> <td data-bbox="797 716 943 789">R4 583</td> <td data-bbox="943 716 1089 789">R5 195</td> <td data-bbox="1089 716 1273 789">R5 739</td> </tr> <tr> <td data-bbox="256 789 505 863">Initiation fee</td> <td data-bbox="505 789 651 863">R1 040</td> <td data-bbox="651 789 797 863">R1 040</td> <td data-bbox="797 789 943 863">R1 040</td> <td data-bbox="943 789 1089 863">R1 040</td> <td data-bbox="1089 789 1273 863">R1 040</td> </tr> <tr> <td data-bbox="256 863 505 940">Total repayment</td> <td data-bbox="505 863 651 940">R15 540</td> <td data-bbox="651 863 797 940">R96 560</td> <td data-bbox="797 863 943 940">R166 028</td> <td data-bbox="943 863 1089 940">R250 400</td> <td data-bbox="1089 863 1273 940">R345 380</td> </tr> </tbody> </table> <p data-bbox="256 982 992 1014">Study the table above and answer the following questions</p>	Loan Repayment Loan term	12 months	24 months	36 months	48 months	60 months	Loan amount	R10 000	R50 000	R100 000	R150 000	R200 000	Monthly repayment	R1 200	R3980	R4 583	R5 195	R5 739	Initiation fee	R1 040	R1 040	R1 040	R1 040	R1 040	Total repayment	R15 540	R96 560	R166 028	R250 400	R345 380	
Loan Repayment Loan term	12 months	24 months	36 months	48 months	60 months																											
Loan amount	R10 000	R50 000	R100 000	R150 000	R200 000																											
Monthly repayment	R1 200	R3980	R4 583	R5 195	R5 739																											
Initiation fee	R1 040	R1 040	R1 040	R1 040	R1 040																											
Total repayment	R15 540	R96 560	R166 028	R250 400	R345 380																											
2.1	Define the term Interest?	2																														
2.2	How much interest will you pay on a loan amount of R150 000, 00 (excluding initiation fees)?	2																														
2.3	What is the longest loan term? Write your answer in years.	2																														
2.4	Show how the total payment was calculated for a loan of R50 000.	3																														
TOTAL		[9]																														

SUBJECT: MATHEMATICAL LITERACY	
TOPIC: FINANCE	
SECTION: BANKING	
LESSON OBJECTIVES	<p>The learner must be able to:</p> <ul style="list-style-type: none"> ○ Differentiate between a Debit Balance and a Credit balance ○ Differentiate between a Credit and a Debit ○ Differentiate between a Stop Order and a Debit Order ○ Understand ALL charges in relation to the banking system ○ Differentiate between Interest and Interest Rate ○ Calculate all Charges associated with Banking
KEY CONCEPTS TERMINOLOGY VOCABULARY	<p>CREDIT BALANCE: There is Money in the account</p> <p>DEBIT BALANCE: An account is overdrawn (Owing the bank Money)</p> <p>OVERDRAFT: The bank allows an account holder to debit on an account.</p> <p>STOP ORDERS: The account holder instructs the bank to make monthly payments to a service provider.</p> <p>DEBIT ORDERS: Service provider issues an instruction to your bank to deduct a payment to your service provider.</p> <p>INTEREST: Money earned on any investments or Money paid to borrow money.</p> <p>INTEREST RATE: The rate at which interest is paid or earned expressed as a percentage.</p> <p>OPENING BALANCE: Amount shown first on a financial statement.</p> <p>CLOSING BALANCE: Amount shown last on the bank statement.</p>
PRIOR-KNOWLEDGE/ BACKGROUND KNOWLEDGE	
<ul style="list-style-type: none"> • Income and Expenses • Budget (Personal and Corporate) • Percentage • Calculating discounts using percentages 	

- Simple and Compound Interests calculations
- Financial Documents

INTRODUCTION

There are different types of bank accounts and they depend on bank to banks.

For example: Savings accounts – Customers earn money in the form of interest but there are no credit or cheque cards. Fixed deposit accounts – A lump sum is deposited each month for a specific period with specific interest. Money cannot be withdrawn. Transaction accounts – Money is available to be used for a variety forms as a stop order, debit order, or EFT. Transaction fees are charged for using the account.

EXAMPLES WITH SOLUTIONS

1.1 VBS bank charges R3,80 for withdrawing between R0 – R1 000 for every R100 withdrawn. While Usuthu Bank charges a fixed amount of R15 for a withdrawal less than R1 000 then R3,80 for every R100 withdrawn above R1000. Which bank will cost less for withdrawing R5 000?

SOLUTION: VBS Bank : $R3,80 \times 50$
40

R190

Usuthu Bank : $R15 + R3,80 \times$

$R15 + 152$

$= R167$

I will choose Usuthu Bank

2. Below is a table showing TWO banks' transactional charges between 2018 and 2019.

	<i>VBS BANK</i>	<i>USUTHU BANK</i>
TRANSACTIONS	Fees	Fees
MONTHLY FEES		
<i>Monthly maintenance fee</i>	R25,00	R50
<i>Self – Service subscription fee</i>	R15,00	R5,00
DEPOSITS		
<i>Cash over the counter</i>	R8,25 + 2% of deposited amount	R15,00 + 5% the amount deposited
<i>Cash at ATM</i>	R5,00	R1,50
CASH WITHDRAWALS		
<i>Over the Counter</i>	R100 + R2,50 for every R100	R150 + R3,00 for every R100 withdrawn or part thereof

	withdrawn or part thereof	
<i>Own ATM</i>	R5,00	R1,00
<i>Another Bank's ATM</i>	R10,00	R3,50
BALANCE ENQUIRIES		
<i>Over the Counter</i>	R4,00 per page	R6,00 per page
<i>Own ATM</i>	R2,00	Free
<i>Another bank's ATM</i>	R12,00	R2,00
<i>Self-service Banking</i>	R1,20	Free

2.1 Calculate how much it would cost to withdraw R1500 over the counter at VBS bank.

SOLUTION : Cost = R100 + R2,50 (15)
 = R100 + R37,50
 = R137,50

2.2 Pitso is complaining that at VBS bank they are charging him too much and want to change his bank to Usuthu Bank. He performs the following transactions at VBS bank and compares them to Usuthu bank.

- 3 cash deposits at VBS bank ATM
- 2 balance enquiries at VBS bank over the counter with 3 page statement each time.

Show by calculations if his claim is valid or not.

SOLUTION:

Transaction	VBS	Usuthu
Cash deposits	$3 \times R5,00 = \mathbf{R15}$	$3 \times R1,50 = \mathbf{R4,50}$
Balance enquiries	$2 \times (R4,00 \times 3) = \mathbf{R24,00}$	$2 \times (R6,00 \times 3) = \mathbf{R36}$
Total Cost	R39	R40,50

Pitso's claim is Invalid

3. MrNgwagwane is planning to buy a house and found an advertisement on a newspaper that had a table shown below:

Loan Information

<i>Cash Price</i>	R573 000,00
<i>Deposit</i>	8%

<i>Interest Rate</i>	14%
<i>Loan Period</i>	20 years

FNB is willing to grant MrMahlaba a loan using the table above.

3.1 Calculate the deposit he will have to pay?

3.2

SOLUTION: Deposit = $0,14 \times R573\ 000,00$

= R80 220

3.2 Determine the monthly repayment excluding the deposit.

SOLUTION: Outstanding Balance = $R573\ 000 - R80\ 220$

= R492 780

$$\text{Monthly Repayment} = \frac{R492\ 780}{240} \qquad \text{Period} = 20 \times 12 = 240 \text{ years}$$

$$= R2\ 053,25 \text{ per month}$$

ACTIVITIES

1. Credit cards from VBS BANK HAVE AN OPTIONAL cash-back reward system. For every R100 you spend, you earn 1 point and 10 points have a value of R1. A monthly costs of R175 a year to join this reward system.

1.1 How many points will you get annually if you spend R6000 on average each month?

1.2 How much money will you spend to earn 58 000 points?

2. Personal loans have a payback period between 2 to 10 years. Below is a table showing how interest rate changes with the repayment option.

Terms (Months)	12	24	36	48
Monthly repayment on R5 000	R563	R485	R343	R271
Monthly repayment on R20 000	R1089	R907	R786	R609
Interest rate	15%	14,3%	13,6%	13%

2.1 Calculate the total repayment amount for a loan of R20 000 taken over 36 months

2.2 How much money will you make in interest on this loan?

2.3 Calculate how much more will it cost to pay back a R10 000 loan over 48 months.

TOPIC FINANCE	
SECTION EXCHANGE RATES	
OBJECTIVES	
<ul style="list-style-type: none"> ➤ Be able to estimate the value of a currency in relation to other currencies. ➤ Understand the meaning of strong and weak currency. ➤ Developing an understanding of the buying power of a currency in a particular country. ➤ Be able to use exchange rate to budget for a holiday. 	
TERMINOLOGY	
<ul style="list-style-type: none"> ➤ Exchange rate - a mean of showing comparison of one currency in relation to another. ➤ Foreign exchange – money system used in a foreign currency. ➤ Buying power - what things cost in a country in relation to what a person earns to that Same country. 	
NOTES	
<ul style="list-style-type: none"> ➤ Many travellers will use an exchange rate as a guideline for the relationship between their home currency and foreign currency. ➤ They use this as the guideline to know how much it will costs them in their home currency to buy something for which the price is given in a foreign currency. 	
WORKED EXAMPLES	
	Marks
Zandile is planning to have a holiday trip with her family to Mozambique during December. She sees two adverts for hotel accommodation in Mozambique VILLA ESPANHOLA : MZN 3000 per night	



HUMULA BEACH RESORT : \$ 1 526 for 14 nights



On the 24th of December Zandile finds the following exchange rates on the internet.

Currencies	Exchange rate
Rand : Metical (MZN)	R1 : MZN 0,2116
Dollar : Rand	\$1 : R15,3238

1	How much it will cost to stay in VILLA ESPANHOLA in Rand for 1 night?	3						
2	How much it will cost to stay in HUMULA BEACH RESORT in Rand for 1 night?	4						
3	Which hotel is the cheapest option for one night? Explain your answer.	3						
4	Which currency stronger between Metical, Rand and US dollar. Why?	3						
5	On the 26 th of December the exchange rate was as follow <table border="1" style="margin-left: auto; margin-right: auto;"> <thead> <tr> <th>Currencies</th> <th>Exchange rate</th> </tr> </thead> <tbody> <tr> <td>Rand : Metical (MZN)</td> <td>R1 : MZN 0,3226</td> </tr> <tr> <td>Dollar : Rand</td> <td>\$1 : R14,3238</td> </tr> </tbody> </table>	Currencies	Exchange rate	Rand : Metical (MZN)	R1 : MZN 0,3226	Dollar : Rand	\$1 : R14,3238	
Currencies	Exchange rate							
Rand : Metical (MZN)	R1 : MZN 0,3226							
Dollar : Rand	\$1 : R14,3238							
5.1	Determine the new prices for one night on each hotel on this day	4						
5.2	Is the Rand stronger or weaker on this day?	2						
TOTAL		19						

ACTIVITY																	
	<p>Baobab Sea Lodge is a hotel on the Kenyan coastline. Phetolo intends to spend two weeks at this hotel, especially as her uncle runs the hotel and has offered him 75% discount on the advertised price. The prices of the hotel and pictures of the hotel are given below.</p>																
	 <table border="1" style="margin-left: auto; margin-right: auto;"> <thead> <tr> <th colspan="3">TARIFFS</th> </tr> <tr> <th>Period</th> <th>Single</th> <th>Double</th> </tr> </thead> <tbody> <tr> <td>07/12/2020 - 31/12/2020</td> <td>Euro 100</td> <td>Euro 130</td> </tr> <tr> <td>01/01/2021 - 15/01/2021</td> <td>Euro 75</td> <td>Euro 100</td> </tr> <tr> <td>16/01/2021 - 31/01/2021</td> <td>Euro 115</td> <td>Euro 155</td> </tr> </tbody> </table>	TARIFFS			Period	Single	Double	07/12/2020 - 31/12/2020	Euro 100	Euro 130	01/01/2021 - 15/01/2021	Euro 75	Euro 100	16/01/2021 - 31/01/2021	Euro 115	Euro 155	
TARIFFS																	
Period	Single	Double															
07/12/2020 - 31/12/2020	Euro 100	Euro 130															
01/01/2021 - 15/01/2021	Euro 75	Euro 100															
16/01/2021 - 31/01/2021	Euro 115	Euro 155															
1	What would Phetolo pay (in Euro) for his holiday if she arrives on the evening of the 23/12/2020 and departs on the morning of 06/01/2021?	4															
2	The exchange rate of the Rand to the Euro (£) at the time of Phetolo's trip is approximately R9, 00 for £ 1, 00. Calculate the cost of the accommodation in Rand for the whole stay, after the discount.	3															
3	<p>The table below shows the approximate prices of certain items in Nairobi</p> <table style="margin-left: auto; margin-right: auto;"> <tbody> <tr> <td>MacDonald's Combo Meal</td> <td>KES 440</td> </tr> <tr> <td>Bottle of water (1,5 litres)</td> <td>KES 80</td> </tr> <tr> <td>Loaf of bread</td> <td>KES 60</td> </tr> </tbody> </table> <p>The exchange rate of the Kenyan Shilling to the Rand is KES10, 3106: R1, 00. Work out the Rand values of the items above</p>	MacDonald's Combo Meal	KES 440	Bottle of water (1,5 litres)	KES 80	Loaf of bread	KES 60	6									
MacDonald's Combo Meal	KES 440																
Bottle of water (1,5 litres)	KES 80																
Loaf of bread	KES 60																
4	Based on your answers in question 3 above, do you think that Phetolo will find it expensive to buy things in Nairobi? Why?	3															
	TOTAL	16															

TOPIC:	MAPS AND PLANS
SECTION:	SYMBOLS ON FLOOR PLANS
	ELEVATIONS
OBJECTIVES	
The learner will be able to use the following plans:	
<ul style="list-style-type: none">• rough and scaled floor/layout plans showing a top view perspective• rough and elevation plans (front, back and side) showing a side view perspective	
In the context of:	
<ul style="list-style-type: none">• a complex structure (e.g. house → RDP house)	
In order to:	
Understand the symbols and notation used on plans	
(e.g. the symbol for a window is a double line; the symbol for a door is a vertical line attached to a quarter circle indicating the swing direction of the door).	
Understand the terms	
“North Elevation”/ “South Elevation”/ “East Elevation”/ “West Elevation”	
and the relevance of compass directions in the construction of buildings.	
Connect the features shown on elevation plans with features and perspectives shown on a floor plan of the same structure.	
TERMINOLOGY Plan/Elevation/Compass directions	

NOTES

ELEVATIONS

An **ELEVATION** is a view from a particular direction

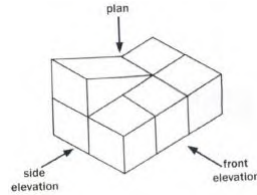

DIAGRAM ONE

- The Front elevation is the view you see from the front
- The Side elevation is the view you see from the side. Can be divided into right and left.

A scale is used to draw a big object, like a house, on a piece of paper.

- North elevation is the view or drawing of the side facing north.



North elevation view

- South elevation is the view or drawing of the side facing south.

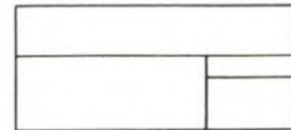

South elevation view

- East elevation is the view or drawing of the side facing east.

- West elevation is the view or drawing of the side facing west.



West elevation view

- The plan of an object is the view from above.

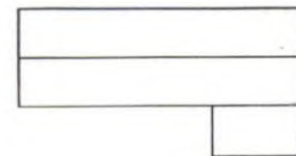
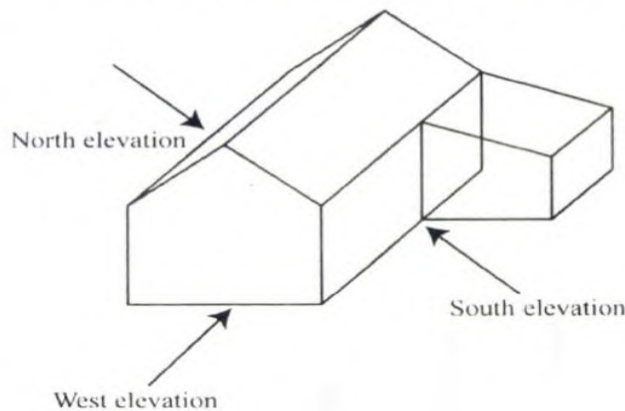

Plan

QUESTION 1

Marks

1.1 Draw the plan; front elevation and side elevation for diagram one

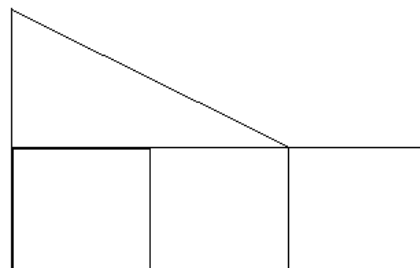

FRONT VIEW

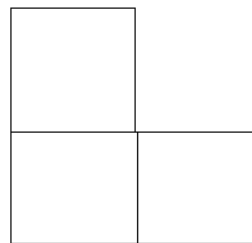

LEFT VIEW

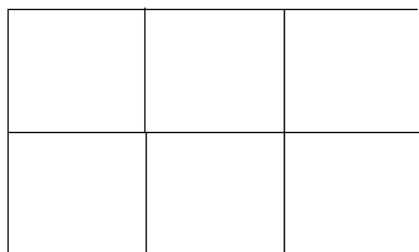

ACTIVITIES

QUESTION 1

Marks

Lunga is building a Granny flat in his backyard. The plan drawer has drawn the plan but asked Lunga to sketch the elevation. Lunga managed to sketch the West elevation only (as shown below)

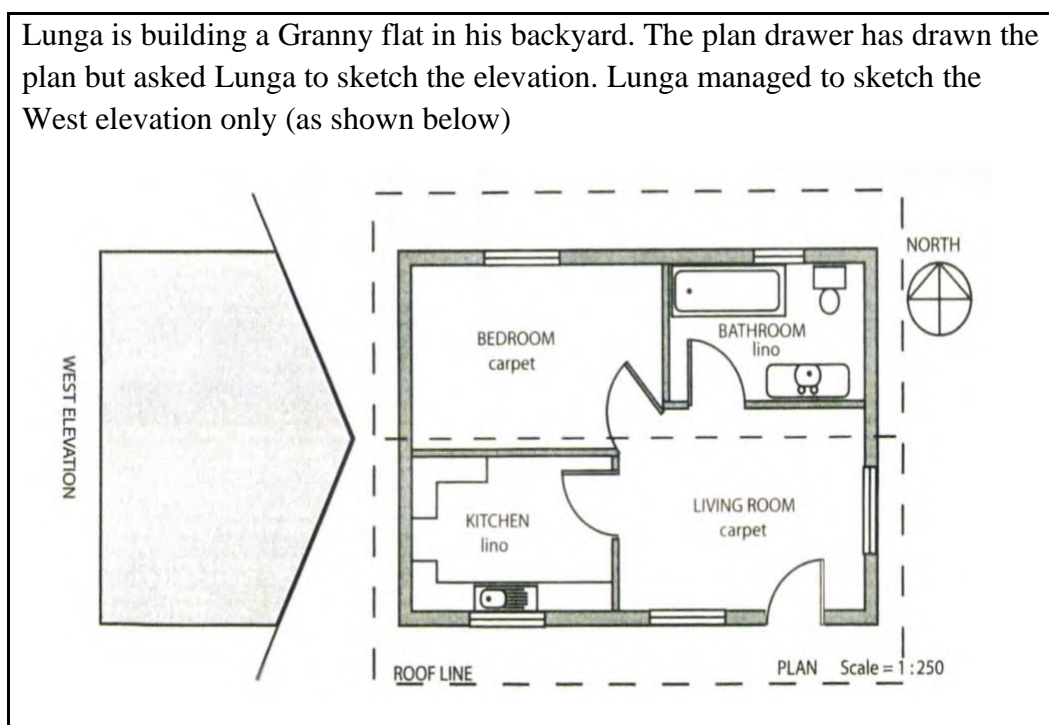

- 1.1 What type sink is found in the kitchen? (2)
- 1.2 When Lunga enters his flat, which room will he be entering? (2)
- 1.3 Describe how the bedroom door will open when Lunga is leaving the bedroom (2)
- 1.4 Name the features shown in the bathroom (3)
- 1.5 Why is the kitchen and bathroom floor covered in lino and not carpet? (2)

- 1.6 How many windows are there in the west elevation? (2)
- 1.7 How many windows are there in the east elevation? (2)
- 1.8 How many doors are there in the north elevation? (2)
- 1.9 How many windows are there in the north elevation? (2)
- 1.10 Sketch the south elevation (3)

TOTAL

[22]

TOPIC: MAPS AND PLANS
SECTION:MAPS
OBJECTIVES <ul style="list-style-type: none">➤ A learner should be able to convert the scale and write the scale in a form of 1 :.....➤ Use the scale to calculate the actual or map distance or length.
TERMINOLOGY <ul style="list-style-type: none">➤ Scale: how many times smaller an object shown on a map.➤ Bar scale: is a picture that shows how far the actual distance will be when you take measurement on the map➤ Number scale: is written in ratio format
NOTES <ul style="list-style-type: none">➤ Scale: how many times smaller an object shown on a map.➤ Bar scale: is a picture that shows how far the actual distance will be when you take measurement on the map.➤ Number scale: is written in ratio format.➤ Advantages of number and bar scale.➤ Advantages of number and bar scale.➤ Convert the scale in the form of 1:..... .

1

WORKED EXAMPLE



Use the map of South Africa to answer the following questions.

1. What is the name of the scale used on the map?
2. What is the advantage of using this scale?
3. Measure the map distance in mm between East London and Durban.
4. Use the scale to calculate the actual distance in Km.

Solutions

1. Bar scale
2. If the map is enlarged or reduced the scale will give accurate lengths or Distances.
3. 60mm (not accurate please re measure)
4. 20mm : 200km *20mm(not accurate please re measure)
60mm : X

$$X = 600 \text{ km}$$

ACTIVITY

Mthembu family lives in Pietermaritzburg. A map of South Africa is given below showing the different towns

1	Use the map to measure the actual distance in km between Johannesburg and Pietermaritzburg.	5
2	Convert the scale given to the form of 1:	4
3	Name ONE advantage of a bar scale	2
	TOTAL	[11]

TOPIC:	MEASUREMENTS
SECTION:	CONVERSIONS
OBJECTIVES: 	<p>In this section you will learn the following</p> <ul style="list-style-type: none"> • how to convert between the units of measurement (i.e. length, mass and volume) • learn how to convert between the metric units of length(mm, cm, m and km), mass(g, mg and kg) and volume(ml and litres) • how convert between metric units and imperial units using the given conversion factors and/or tables • how convert between the solid units and liquid units using the conversion factors or tables • how to convert between the units of temperature(i.e. °F <i>and</i> °C using the formulae • how to use proportion and conversion to calculate the amount of material required • how to compare solutions to a problem in different units to make a decision as to which unit is appropriate.
TERMINOLOGY	Units of mass Units of length Units of volume(liquids) Express/convert Imperial units Metric units
NOTES	

Km	Km ²	Km ³
1 000	1 000 000	1 000 000 000
m	m ²	m ³
100	10 000	1 000 000
cm	cm ²	cm ³
10	100	1 000
mm	mm ²	mm ³

2 dimension

AREA

$\div 10^2$
 mm^2
 $\times 10^2$

$\div 100^2$
 cm^2
 $\times 100^2$

$\div 1000^2$
 m^2
 $\times 1000^2$

$\div 1000^2$
 km^2
 $\times 1000^2$

VOLUME

$\div 10^3$
 mm^3
 $\times 10^3$

$\div 100^3$
 cm^3
 $\times 100^3$

$\div 1000^3$
 m^3
 $\times 1000^3$

$\div 1000^3$
 km^3
 $\times 1000^3$

PERIMETER

$\div 10$
 mm
 $\times 10$

$\div 100$
 cm
 $\times 100$

$\div 1000$
 m
 $\times 1000$

km

WORKED EXAMPLES

QUESTION 1

<p>1. Convert the following:</p> <p>15cm to mm</p> <ul style="list-style-type: none"> $15cm = 15 \times 10mm$ $= 150mm$ <p>50cm to m</p> <ul style="list-style-type: none"> $50cm = \frac{50}{100}m$ $= 0.5m$ or $50cm = 50 \times \frac{1}{100} = 0.5m$ <p>2km to m</p> <ul style="list-style-type: none"> $2km = 2 \times 1000m$ $= 2000m$ <p>2. Express:</p> <p>2litres as ml</p> <ul style="list-style-type: none"> $2litres = 2 \times 1000$ $= 2000ml$ <p>200g as kg</p> $200g = \frac{200}{1000}kg$ $= 0.2kg$ <p>3. Convert the normal body temperature of a human 36.9 degree celcius to degree Farenheit</p> <p>You may use the formula: $^{\circ}F = (1,8 \times ^{\circ}C) + 32$</p> <ul style="list-style-type: none"> $^{\circ}F = (1,8 \times ^{\circ}C) + 32$ $= (1.8 \times 39.6) + 32$ $= 71.28 + 32$ $^{\circ}F = 103.28$ 	<p>4. If 1cup =250ml and 1teaspoon = 5ml and 1tablespoon =15ml</p> <p>Calculate how many tablespoons are there in 1cup</p> <ul style="list-style-type: none"> from conversion factors <p>Number of 15ml in 250ml will be equal to the number of tablespoons in 1cup</p> $tablespoons = \frac{250}{15}$ $= 16.666666 \text{ tbspn}$ $= 16.67 \text{ tbspn}$ <p>$\frac{3}{4}$ cup is equal to how many ml?</p> $\frac{3}{4} \text{ cup} = \frac{3}{4} (250ml)$ $= 187.5ml$ <p>OR</p> $1 \text{ cup} = 250ml$ $0.75 \text{ cup} = ? \text{ ml}$ $ml = 0.75 \times 250ml$ $= 187.5ml$
--	--

ACTIVITIES

	<p>Given below is a simple cheese and tomato pizza recipe. Study the recipe and answer the questions that follow.</p>
--	---

<p>SIMPLE CHEESE AND TOMATO PIZZA</p> <p>(Makes 1 large pizza)</p> <p>$\frac{3}{4}$ cup homemade pizza dough</p> <p>1 tbs olive oil</p> <p>2 cloves garlic</p> <p>75 ml tomato paste</p> <p>0,23 kg mozzarella cheese</p> <p>2 tomatoes</p> <p>Salt and pepper to taste</p> <p style="text-align: right;">Remember: 1 cup = 250 ml 1 Tablespoon = 15 ml</p>	
--	--

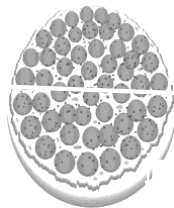

1.1	Convert the amount of cheese to grams	2
1.2	How many tablespoons of tomato paste are needed for this recipe?	2
1.3	Determine the amount of homemade pizza dough needed for 3 large pizzas. Give your answer to the nearest millilitres (ml).	4
1.4	If there is 1 litre of tomato paste available, how many pizzas can be made from it?	3
		/11/

ACTIVITY 2

Layla likes baking chocolate muffins at home. She wants to bake 24 muffins in one tray at 180°C for 25 minutes.

	<p>Ingredients (24 muffins)</p> <p>1 kg snow flake chocolate muffin mix</p> <p>4 extra-large eggs</p> <p>310 ml (1$\frac{1}{2}$) cup cooking oil</p> <p>400 ml water</p>	
--	--	--



[Source: fotosearch.com]

2.1.	How many grams of snowflake chocolate muffin mix will she need to bake 48 chocolate muffins?	4
2.2.	Convert 180°C to $^{\circ}\text{F}$ Use the formula: $^{\circ}\text{F} = (1,8 \times ^{\circ}\text{C}) + 32^{\circ}$	2
2.3	If she started baking at 05:30:56 am., what will be her finishing time?	2
2.4	She was approached by the Pet Primary School to serve their 117 learners with the chocolate muffins on the school's birthday. Each learner gets one muffin. How many trays of muffins will she bake for the school?	

ACTIVITY 3

3. Mr Rankhakile is a fisherman. Before he goes to the sea shore to fish, he studies the tide table. Below are the two tide tables for Durban showing tides for Tuesday 28/01/2020 and Wednesday 29/01/2020.

28/01/2020				29/01/2020			
Tide	Time	Height		Tide	Time	Height	
Hightide	5:44am	1,91m		Hightide	6:13a m	1,86m	
Lowtide	11:49am	0,43m		Lowtide	12:18p m	0,50m	
Hightide	5:49pm	1,8m		Hightide	6:17p m	1,76m	
Lowtide	11:59pm	0,35m		Lowtide			
Surmise 5:20am	Sunset 6:56pm	Moon rise 8:17 am	Moon set 9:21pm	Sun rise 5:21am	Sunset 6:55 pm	Moonrise 9:10 am	Moonset 9:51pm

3.3	Convert the height of the hightide on 29 January 2020 in the afternoon to feet (ft) Note: 1 foot = 30,48 cm	4
-----	---	---

ACTIVITY 4

- 4 Kim is the young botanist who is in love with the birds and in her house she has a bird cage for keeping different kinds of birds. She is planning to build a concrete floor for his bird cage for keeping the on the safe



Concrete

Wheelbarrow

Bucket

50kg of Cement

Kim needs a concrete mixture of $0.27m^3$ of cement, sand and gravel to make a concrete floor for his bird cage. He has a bucket with a capacity of 8 ℓ and a wheelbarrow with a capacity of 50ℓ.

Assume that $1 m^3 = 1000 \text{ litres}$

$1 \text{ kg} = 1 \text{ litre}$

4.1	Calculate how many litres of concrete mixture will be needed to build a floor for his cage.	2
4.2	Kim made a claim that she is going to need more than 10 kg of cement and more 3kg of gravel to make the concrete cage for the birds. If the ratio of cement to sand to gravel is 1 : 3 : 5 to make a $0.27m^3$. Verify if her claims are valid.	6
4.3	Calculate the number of buckets of sand she is going to need to make the concrete of $0,27m^3$	4

ACTIVITY 5

The Wimbledon tennis championships are held in London annually. Wimbledon has a total of 41 grass courts consisting of 19 match courts and 22 practice courts.

TABLE 2 below shows some interesting facts about Wimbledon.

TABLE 2: SOME INTERESTING FACTS ABOUT WIMBLEDON

Grounds (size)	13,5 acres
Car parks	42 acres
Grounds (capacity)	39 000 spectators on the grounds at any time
Centre Court (main court)	14 979 seats Maximum spectators: 15 000
No. 1 Court	11 393 spectators
Staff size	6 000
Large TV screen (size)	40 square metres

NOTE: 1 acre = 4.07m²

5.1	Express the area of the carparks in square metres	2
5.2	Express the size of a tv screen in square centimetres	2
5.3	Calculate the maximum density (to the nearest unit) of the spectators at the Wimbledon grounds. Express your answer in square metres. You may use the formula: $\text{density of spectators} = \frac{\text{number of spectators}}{\text{ground size in acres}}$	3

TOPIC: MEASUREMENTS

SECTION: AREA

OBJECTIVES: The Learners should be able to:

- Explain the meaning of terms (e.g. “area”, “perimeter”, “volume”, “radius”, etc).
- Identify from a list of given formulae which formulae relate to perimeter calculations, which relate to area calculations, etc.
- Determine the radius of a circle from a given diameter.
- Know that area is expressed in units² (e.g. *cm*²)
- Calculate area by substituting given values to the given formulae.
- Perform preliminary calculations to determine dimensions required in area calculations and then calculate area.

Use area calculations to complete a project, where it is not stated specifically what type of calculation is required.

TERMINOLOGY: AREA, RADIUS, UNIT OF MEASUREMENT, 2-D DRAWING, CIRCUMFERENCE, DIAMETER, LENGTH, ROUNDING OFF

NOTES

WORKED EXAMPLES

Skateboarders often enjoy performing tricks on a special ramp called a halfpipe (shown alongside).

1. Use the diagrams alongside to calculate the area of the curved skating surface of the halfpipe.

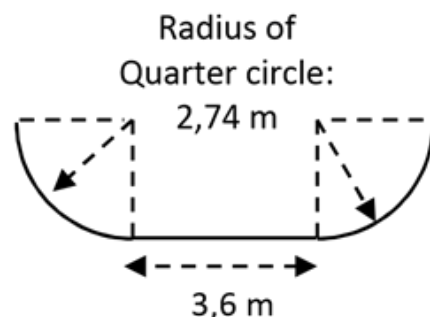

Answer:

If a surface has the same width all along its length, it then forms a large rectangle, so we can calculate the length of the edge and use it as the length of the rectangle:

$$\begin{aligned} \text{Total length of the edge} &= 2 \times \frac{1}{4} \times \pi \times d + 3.6 \text{ m} \\ &= 2 \times (0,25) \times (3,142) \times (5,48 \text{ m}) + 3,6 \text{ m} \\ &= 8,61 \text{ m} + 3,6 \text{ m} \\ &= 12,21 \text{ m} \end{aligned}$$

$$\begin{aligned} \text{Therefore, total area of ramp surface} &= \text{length} \times \text{breadth} \\ &= 12,21 \text{ m} \times 13 \text{ m} \\ &= \mathbf{158,73 \text{ m}^2} \end{aligned}$$

2. A special board is used on the surface. The board is sold in rectangular pieces (width: 1,5 m, length: 3,0 m). Use the area of the board to *estimate* the number of boards needed to cover the skate surface of this halfpipe.

Answer:

We can only *estimate* the number of boards as we would need to check how the boards fit together, but an estimate is useful when getting a rough idea of how many boards might be needed:

We can estimate the number of boards by dividing the area of one board into the total area of the ramp:

$$\begin{aligned} \text{Area of 1 board} &= \text{length} \times \text{breadth} \\ &= 1,5 \text{ m} \times 3,0 \text{ m} \\ &= 4,5 \text{ m}^2 \end{aligned}$$

$$\begin{aligned} \text{Number of boards} &= \text{Total area} \div \text{Area of 1 board} \\ &= 158,73 \text{ m}^2 \div 4,5 \text{ m}^2 = 35,27 \text{ boards} \approx \mathbf{36 \text{ boards needed.}} \end{aligned}$$

ACTIVITIES

ACTIVITY 1 [15 MARKS]

The scale drawing below shows the plan of a small farm

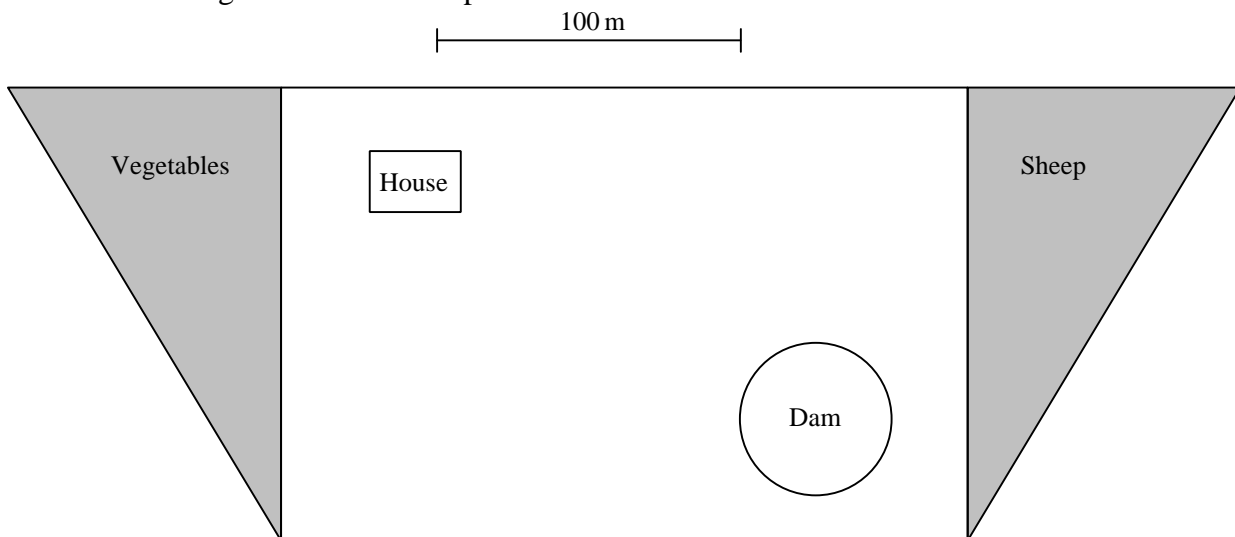

What is the total area of the farm? (7)

Estimate how far it is from the corner of the house nearest to the dam to the edge of the dam itself. (2)

What is the area of the dam? (The area of a circle is πr^2 .) (3)

If the dam is 3 m deep, how many litres of water does it contain? ($1 \text{ m}^3 = 1 \text{ kl}$) (3)

ACTIVITY 2 [11 MARKS]

The main field at SIMINUYE High School is converted to an athletic track which consists of semi-circles and rectangular areas as shown below..

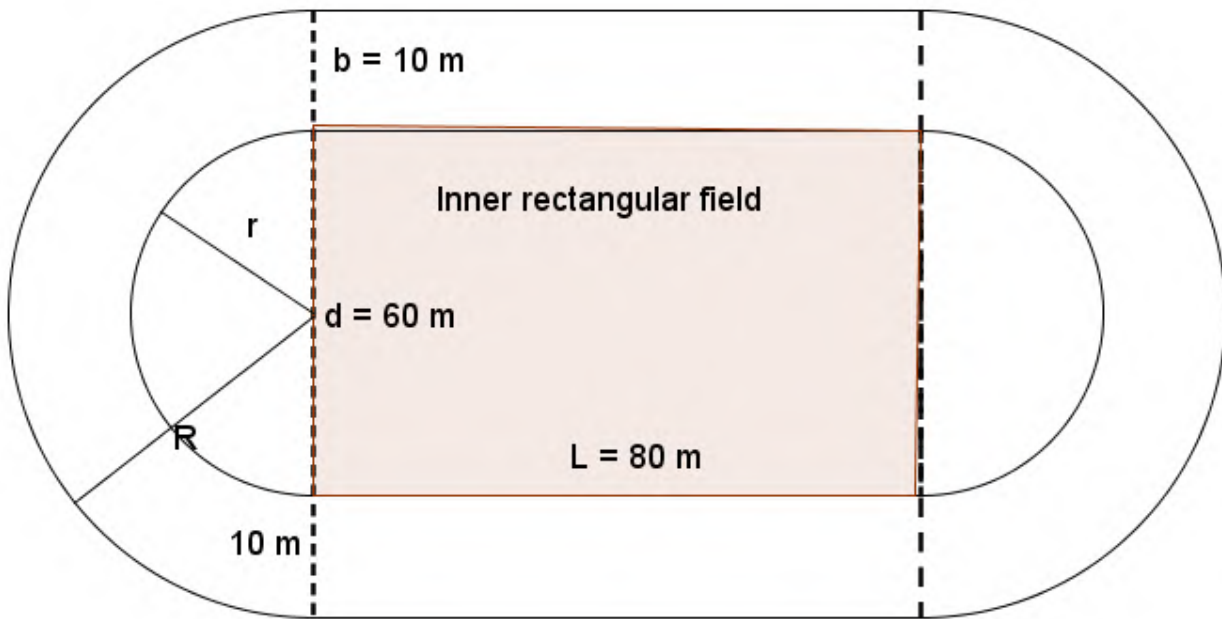

The diameter of the inner semi-circles is 60 m. The distance between the inner and outer semi-circle is 10 m. The track consists of an 80 m straight.

2.1 Calculate the diameter of the outer semi-circle (2)

2.2 Calculate the outer perimeter of the track, using the formula:

Perimeter = π (diameter of outer semi-circle) + 2 length of straight (use $\pi = 3,142$) (3)

2.3 The school decides to use the inner rectangular field for field events. Calculate the area of this rectangular field.

(Area of rectangular field = length width) (2)

2.4 Calculate the area available for running the various track events, using the formula: Area for track events = $\pi (R - r)^2 + 2 (L b)$ (use $\pi = 3,142$) (4)

Note: R is the radius of the outer semi-circle

r is the radius of the inner semi-circle

L is the length of the straight

b is the distance between the semi-circles

ACTIVITY 3 [26 MARKS]

Mr Blauw, a teacher at Bayview High school asks a local pool builder to build a pool with dimensions as shown in the diagram below. The pool has a depth of 1 m at the shallow end and 2,5 m at the deep end.

The pool is made up of the following geometric shapes:

☐ Rectangles at the shallow end (4 m by 1 m) and at the deep end (4 m by 2,5 m). Thus, the **width** of the pool is 4 m.

☐ Trapeziums on the sides with **parallel sides** 1 m and 2,5 m and height 10 m. NB: The **height** of the trapezium is the **length** of the pool.

☐ A rectangle on the base with dimensions 12 m by 4 m

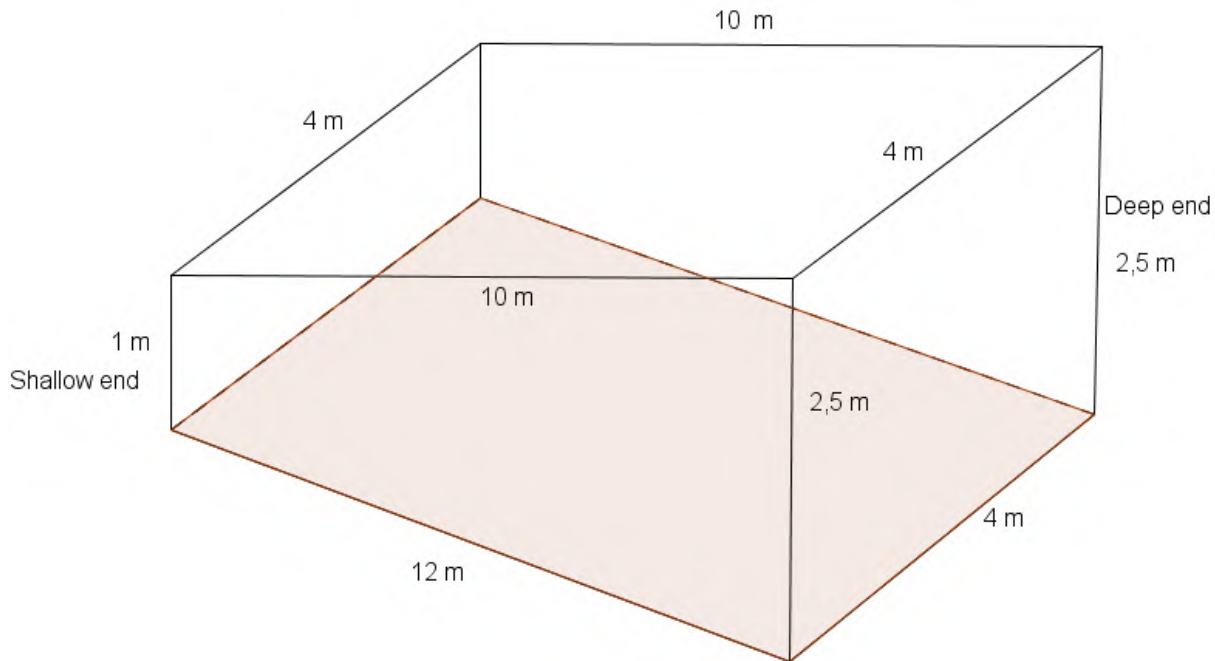

3.1 Calculate the area of the one of the side surfaces (trapezium).

Use the formula:

$$\text{Area of trapezium} = \frac{1}{2} (\text{sum of parallel sides}) (\text{height of the trapezium}) \quad (4)$$

3.2 All inner surfaces of the pool have to be tiled. Calculate the area (in m^2) of the surfaces to be tiled.

Use the formula:

$$\text{Area of tiled surfaces} = 2 \text{ area of the side surfaces (trapeziums)} + \text{area of the base} + \text{area of rectangle at shallow end} + \text{area of rectangle at deep end} \quad (5)$$

3.3 Workmen who tile always order 10% more than the number of square metres of tiles needed, rounded off to the nearest whole number. Determine the number of square metres of tiles ordered. (2)

3.4 The dimensions of each tile is 15 cm by 15 cm.

3.4.1 Calculate the area of one tile (in cm^2). (2)

3.4.2 Calculate the number of tiles purchased. (NB: $1 \text{ m}^2 = 10000 \text{ cm}^2$) (3)

3.5 The cost of the tiles is R79,99 per square metre.

3.5.1 Calculate the total cost of the tiles purchased. (2)

3.5.2 Calculate the cost of one tile. (2)

3.6 The pool is filled to capacity.

3.6.1 Calculate the volume of water which can be filled in the pool. Leave your answer in kilolitres (kl). ($1 \text{ m}^3 = 1 \text{ kilolitre}$)

Use the following formula:

$$\text{Volume} = \text{Area of trapezium (from question 2.1)} \times \text{width of the pool} \quad (3)$$

3.6.2 The municipality charges R4,99 (excluding VAT) for each kilolitre of water. What is the cost, including VAT, to fill the pool? (3)

TOPIC:MEASUREMENTS
SECTION:MASS (WEIGHT)
OBJECTIVES: Learners should be able to: <ul style="list-style-type: none"> • Determine mass (weight using appropriate measuring instrument. • Perform complex projects in both familiar and unfamiliar contexts • Calculate cost of certain amount of product. • Calculate values using formula involving mass (weight)
TERMINOLOGY: conversion, mass, weight Body Mass Index
NOTES: Mass (weight)- measured using (kitchen, bathroom, travelling and electronic scales) <ul style="list-style-type: none"> • In airports they use electronic scale to measure the weight in a luggage • At the butcheries, fruit and vegetable shops they use kitchen scale /electronic scales to measure weight of meat or fruits for pricing. • Health practitioners use bathroom scales to measure babies weight in order to decide on the correct dosage for medicine. Bathroom scales are also used to measure weight of adults for different purposes. <p>Transport department use weigh bridges to weight trucks. The truck driver drives onto a special strip of road that is connected to a digital scale.</p>

WORKED EXAMPLES

QUESTION 1

Marks

- 1.1 1. A lift I a shopping mall has a notice that indicates that it can carry 2,2 tonnes or a maximum of 20 people. Work out what the engineer who built the lift estimated the maximum weight of a person to be in kg.

1 tonne = 1000kg

Solution:

Convert the tonnes: $2.2 \times 1000 = 2\ 200\text{kg}$

Mass of one person: $2\ 200 \div 20 = 110\ \text{kg}$

Engineer estimated the maximum mass of lone person of be 110 kg

- 1.2 1. Determine which bag of sweets is cheaper
Sweet chews: 280 g for R13, 99 and Happy tastes: 320g for R16,50

Solution:

Divide prices by grams to find price for one sweet in both scenarios

Sweet chews: $\frac{R13.99}{280g} = R\ 0.04996428571$

Happy tastes: $\frac{R16.50}{320g} = R0.0515625$

- 1.3 1. Ismail is 16 years old. He weighs 78kg and is 1,62m in height. Using the formula for Body Mass Index

$$BMI = \frac{\text{mass (kg)}}{[\text{height (m)}]^2}$$

Use this information to suggest if Ismail is underweight, normal, overweight or obese

BMI	CLASSIFICATION
< 18.5	underweight
≥ 18.5 and < 25	Normal
≥ 25 and < 30	overweight

≥ 30	obese
-----------	-------

$$BMI = \frac{\text{mass (kg)}}{[\text{height (m)}]^2}$$

$$= \frac{78}{1.62^2}$$

$$= 29.72 \text{ kg/m}^2$$

Ismail is overweight

ACTIVITIES

QUESTION 1

Marks

1.1 The table shows the height and mass for four girls

Use the formula: $BMI = \frac{\text{mass (kg)}}{[\text{height (m)}]^2}$ to complete the table.

	height	Mass	BMI	Status
Lihle	1.60m	72 kg		
Amahle	1.65 m	46 kg		
Okuhle	1.70 m		33kg/m ²	
Lisa		72kg	21 kg/m ²	

(10)

1.2 Which luggage suitcase is the heaviest?

Suitcase A: 2.19kg

Suitcase B: 1.11142t

Suitcase C 4 215 g

NOTE: 1 ton = 1 000kg

(5)

1.3 Calculate the cost of 0.25 pounds of gold, if gold cost R13 070.58 per ounce

Note : 1 ounce = 28.3495g

(3)

TOTAL

[18]

TOPIC: MEASUREMENTS

SECTION: MASS (WEIGHT)/GROWTH CHARTS

OBJECTIVES: Learners should be able to:

- Monitor and manage mass (weight)
- Interpret growth charts

TERMINOLOGY: Reading from the graph

Interpretation

Analysing

NOTES: Types of charts

Road to health charts (for 0-24 months' babies)

Chart for girls (2 -20years)

Charts for boys (2- 20 years)

NB: the charts for girls and boys (0- 20years) are different.

Example

Consider two girls: **Amy** is 9 years old. She is 1,29 m tall and weighs 33 kg.

Nontando is 12 years old. She weighs 46 kg and is 1,52 m tall.

Their BMI's are as follows:

Amy	Nontando
$BMI = \frac{\text{Weight (kg)}}{\text{Height (m)}^2} = \frac{33 \text{ kg}}{(1,29)^2} = \frac{33 \text{ kg}}{1,6641 \text{ kg}^2}$ $= 19,83 \text{ kg/m}^2$	$BMI = \frac{\text{Weight (kg)}}{\text{Height (m)}^2} = \frac{46 \text{ kg}}{(1,52)^2} = \frac{46 \text{ kg}}{2,3104 \text{ kg}^2}$ $= 19,91 \text{ kg/m}^2$

Notice that they both have the same BMI. According to *adult* BMI assessments from Grade 11, both girls are perfectly normal. Now we reference the appropriate BMI growth curve for girls and plot each girl's age versus her BMI:

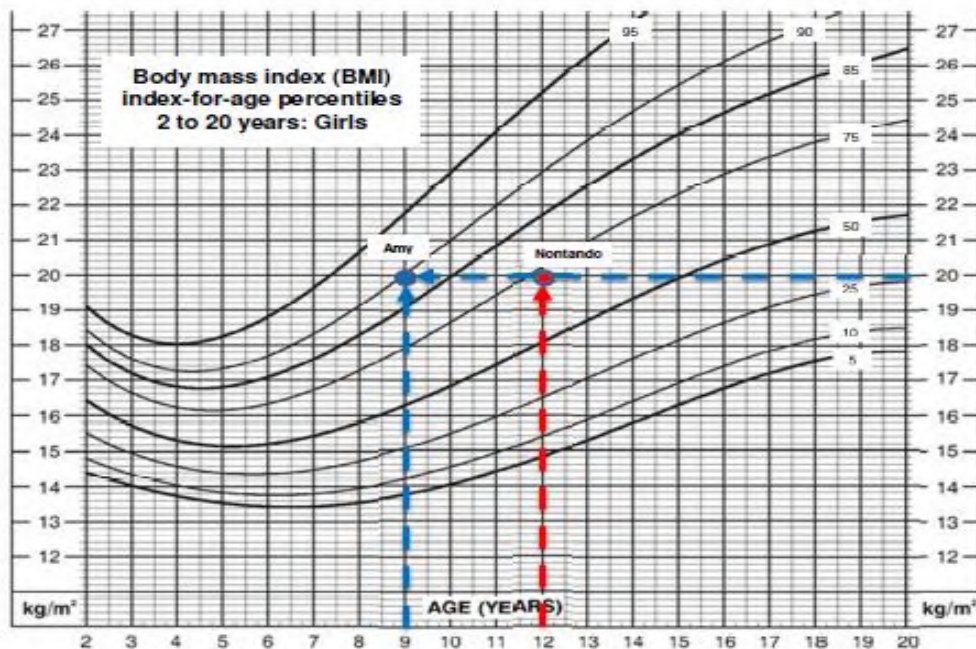

WORKED EXAMPLES

- QUESTION 1** **Marks**
- 1.1** 1. A 16-year-old boy has a BMI of 23kg/m^2 , determine his percentile? **(2)**
- Solution:** draw a vertical line at 16 years and a horizontal line at the BMI of 23kg/m^2 .
- The two lines meet between 75^{th} and 85^{th} .
Therefore, the girls BMI is between 75^{th} and 85^{th} percentile.
- 1.2** What is the BMI of a 17 year old girl if her BMI places her at the 50^{th} percentile? **(2)**
- Solution :** draw a vertical line at 17years until the line touches the 50^{th} curve, then draw a horizontal line to read the BMI
Her BMI 21kg/m^2
- 1.3** Within what range can a 10-year-old boy's BMI be if his weight is to be considered "healthy"? **(4)**
- Solution:** healthy means percentile ranging from 5^{th} to 85^{th}
- Draw a vertical line at 10 years until it touches the 5^{th} percentile curve and draw a horizontal line to read the BMI,
extend the vertical line at 10 years until it touches the 85^{th} curve and draw a horizontal line to read the BMI.
- Ranges from $14,5\text{ kg/m}^2$ to $18,5\text{ kg/m}^2$**
- 1.4** BMI is calculated using formula: **(5)**
- $$\text{BMI} = \frac{\text{mass (kg)}}{[\text{height (m)}]^2}$$
- What is the weight status of a 15 year old learner who is 120cm tall and weighs 45kg? (5) solution : $\text{BMI} = \frac{45}{(1.2)^2}$
- $$= 20\text{ kg/m}^2$$

TOTAL**[13]****ACTIVITIES**

- QUESTION 1** **Marks**
- 1.1** Use the growth charts below and answer questions that follow
Explain what it means that a 7 year old boy has a weight-for-age ratio that places him on the 50^{th} percentile graph **(3)**
- 1.2** Jane and Tom have two girls, Rose who is 2 years old and Joy who is 8 months old. The growth chart for girls is shown in ANNEXURE B in the Use the information above and ANNEXURE B to answer the following questions:
- 1.1** Rose's weight at birth is on the 75^{th} percentile curve. **(2)**

(2)

- (a) Give the other name of the 75th percentile curve. (2)
- (b) Determine Rose's weight (in kg) at birth. (2)
- (c) Rose's weight is on the 75th percentile curve. Explain what this means. (2)
- (d) If there are 35 000 two year old girls in South Africa, how many girls are heavier than Rose?

2.2 Joy's age-for-height relationship lies on the 90th percentile curve. Determine her length in cm.

TOTAL

[]

Jane and Tom have two girls, Rose who is 2 years old and Joy who is 8 months old. The growth chart for girls is shown in ANNEXURE B in the

Use the information above and ANNEXURE B to answer the following questions:

5.1.1 Rose's weight at birth is on the 75th percentile curve.

- (a) Give the other name of the 75th percentile curve. (2)
- (b) Determine Rose's weight (in kg) at birth. (2)
- (c) Rose's weight is on the 75th percentile curve. Explain what this means. (3)
- (d) If there are 35 000 two year old girls in South Africa, how many girls are heavier than Rose? (2)

5.1.2 Joy's age-for-height relationship lies on the 90th percentile curve. Determine her length in cm. S (2)

CDC Growth Charts: United States

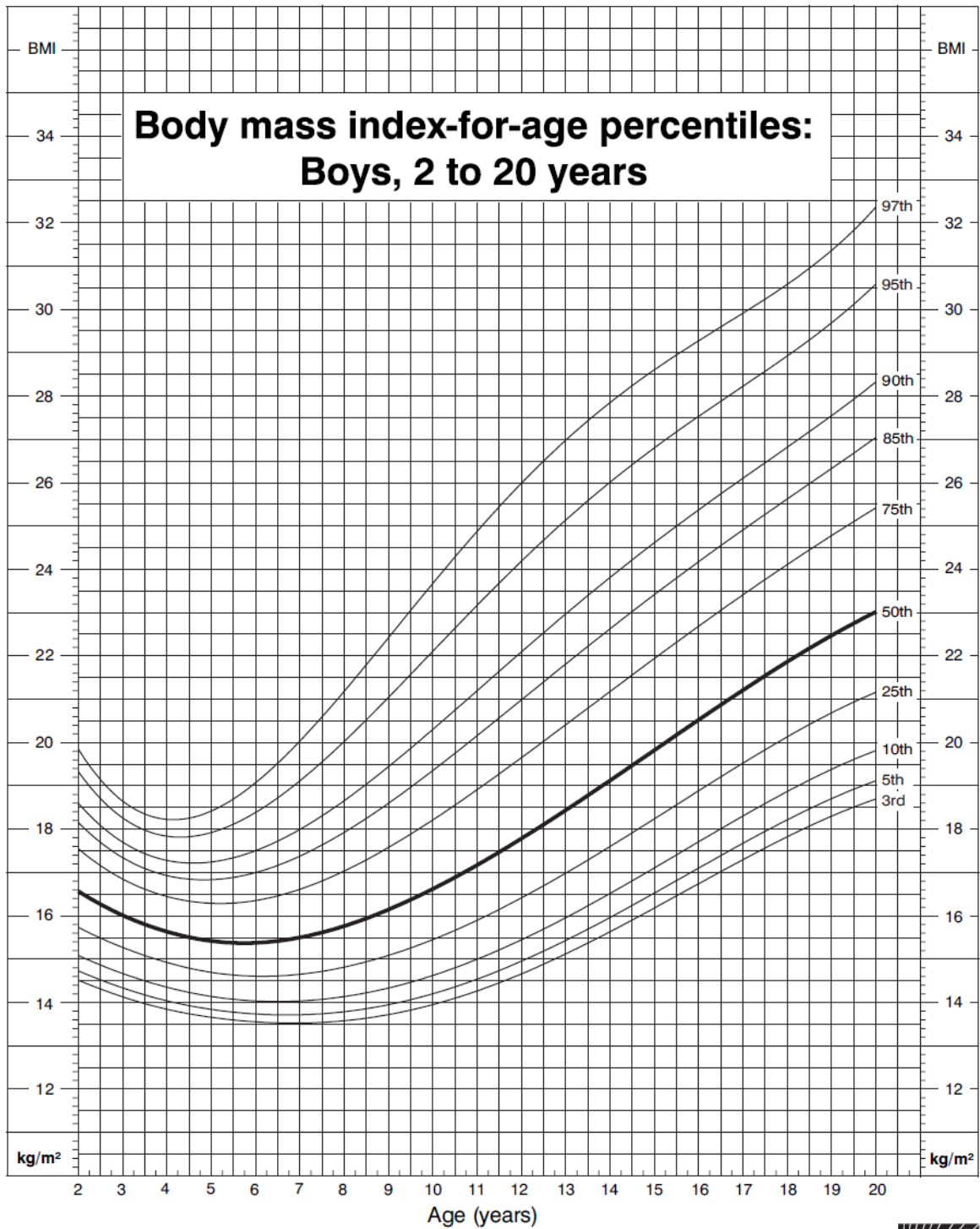

Published May 30, 2000.

SOURCE: Developed by the National Center for Health Statistics in collaboration with the National Center for Chronic Disease Prevention and Health Promotion (2000).



SAFER • HEALTHIER • PEOPLE™

CDC Growth Charts: United States

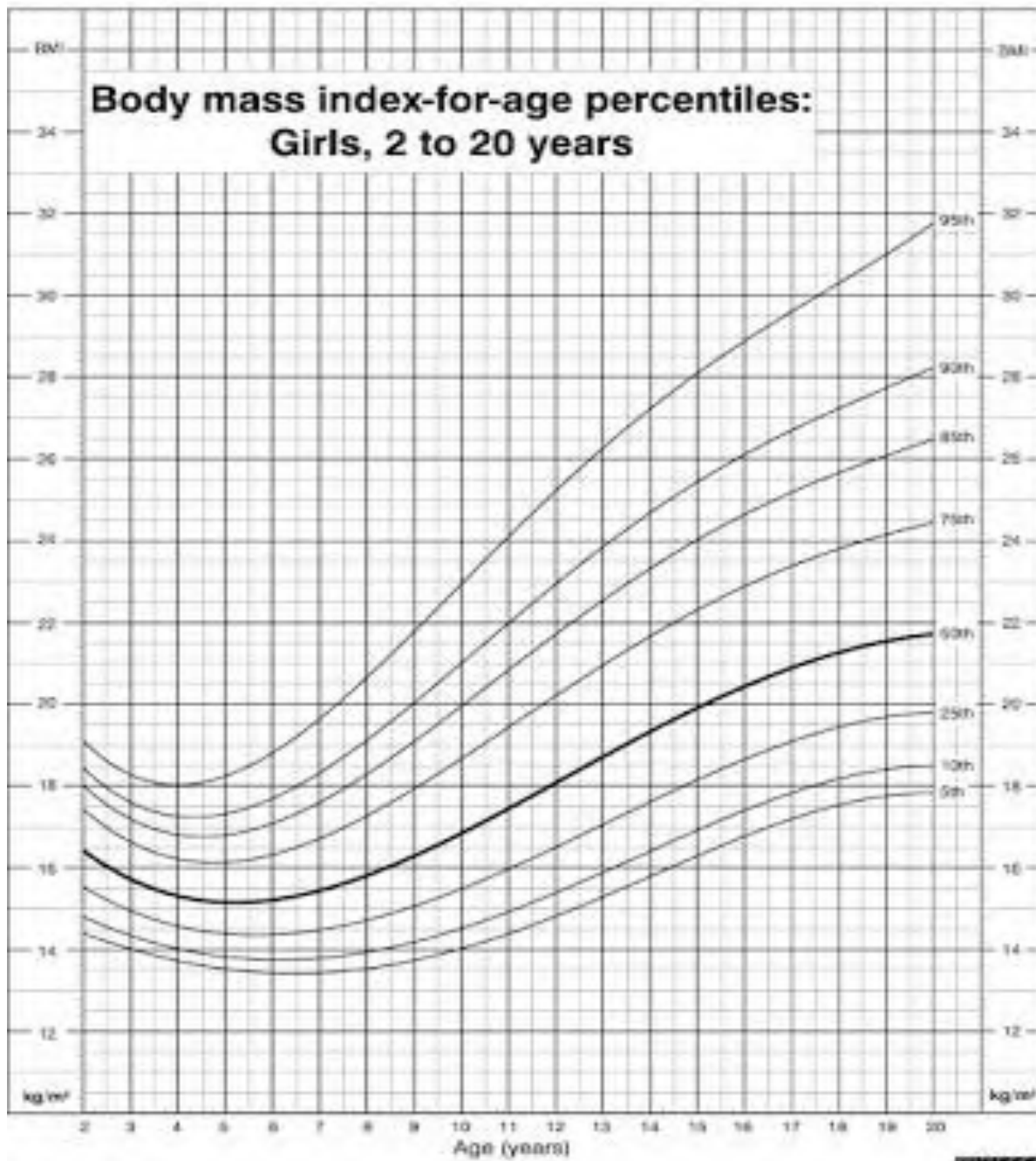

Published May 20, 2000

SOURCE: Developed by the National Center for Health Statistics in collaboration with the National Center for Chronic Disease Prevention and Health Promotion (2000).



SAFER • HEALTHIER • PEOPLE



Birth to 24 months: Girls

NAME _____

Length-for-age and Weight-for-age percentiles

RECORD # _____

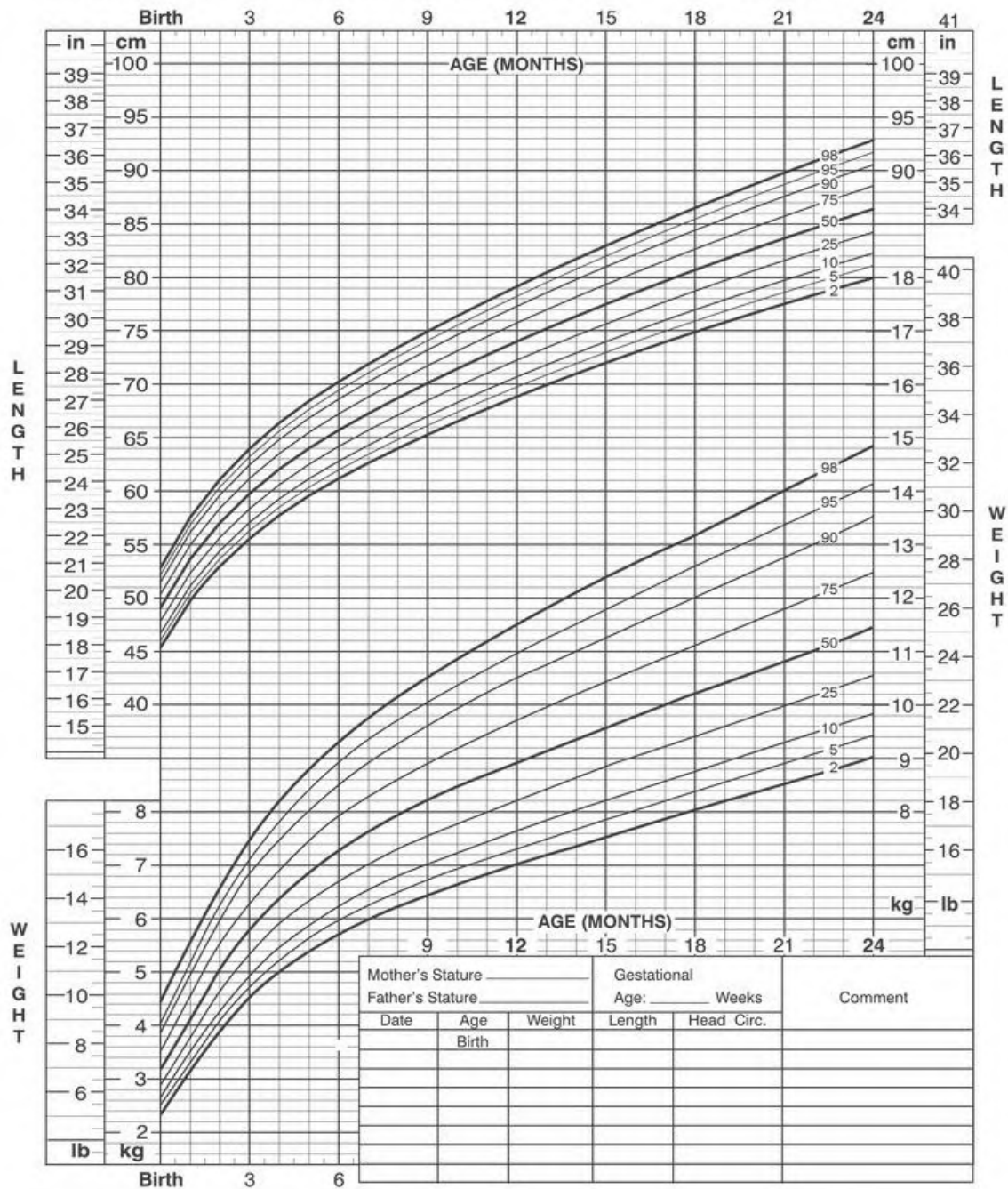

TOPIC: MAPS AND PLANS...

SECTION: ASSEMBLY DIAGRAMS

OBJECTIVES

Learner will be able to use instruction/assembly diagrams, containing words and/or pictures, found in manuals for:

- plugs
- plastic models
- unassembled wooden furniture units
- cell-phones (e.g. installing a battery and sim card; or operating instructions)
- electrical appliances that require individual components to be connected (e.g. connecting speakers to a hi-fi; or connecting an aerial to a television)
- children's toys including Lego-type kits.

In order to:

Complete the task presented in the instructions and/or explain what the instructions mean and/or represent, using everyday language.

TERMINOLOGY

Assemble = put together

Components = parts or pieces

NOTES





WORKED EXAMPLES

QUESTION 1

Marks

Match the picture below with the steps outlined below

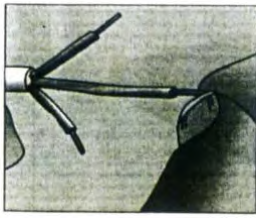
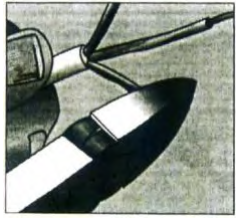
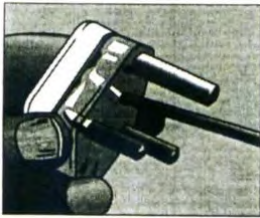
e.g. 1 Z:

A	B	C	D
			
E	F	G	H
			

1. Using cutters/pliers, expose the end of the 3 wires inside the electrical cord by cutting away the plastic. Expose about a centimetre.
2. Twist the strands of copper wire until each strand is wound tight.
3. Remove the cover of the 3 pin plug by unscrewing it. Some plugs snap open with a flat screwdriver.
4. Unscrew the small screws found on each pin.
5. Put the twisted copper wire into the correct holes in the pin.
6. Tighten the little screws to clamp the wires in place
7. Make sure the cord is tightly clamped at the bottom of the plug so that it will not be pulled out.
8. Replace the cover of the plug

1.1 SOLUTION

1. E
2. D
3. F
4. B
5. A
6. C/G
7. C/G
8. H

1.2 What colour wire should be inserted in the top pin?

Green and yellow

1.3 Why is it important to wire an electrical appliance correctly?

If it is not wired correctly, you can get shocked and might die.

The appliance can blow u

TOTAL

[]

ACTIVITIES

QUESTION 1

Marks

1.1 List two of the advantages of using diagrams, instead of words, to show how to assemble something

(4)

1.2 Arrange the instruction diagrams below in the correct order (beginning to ending)

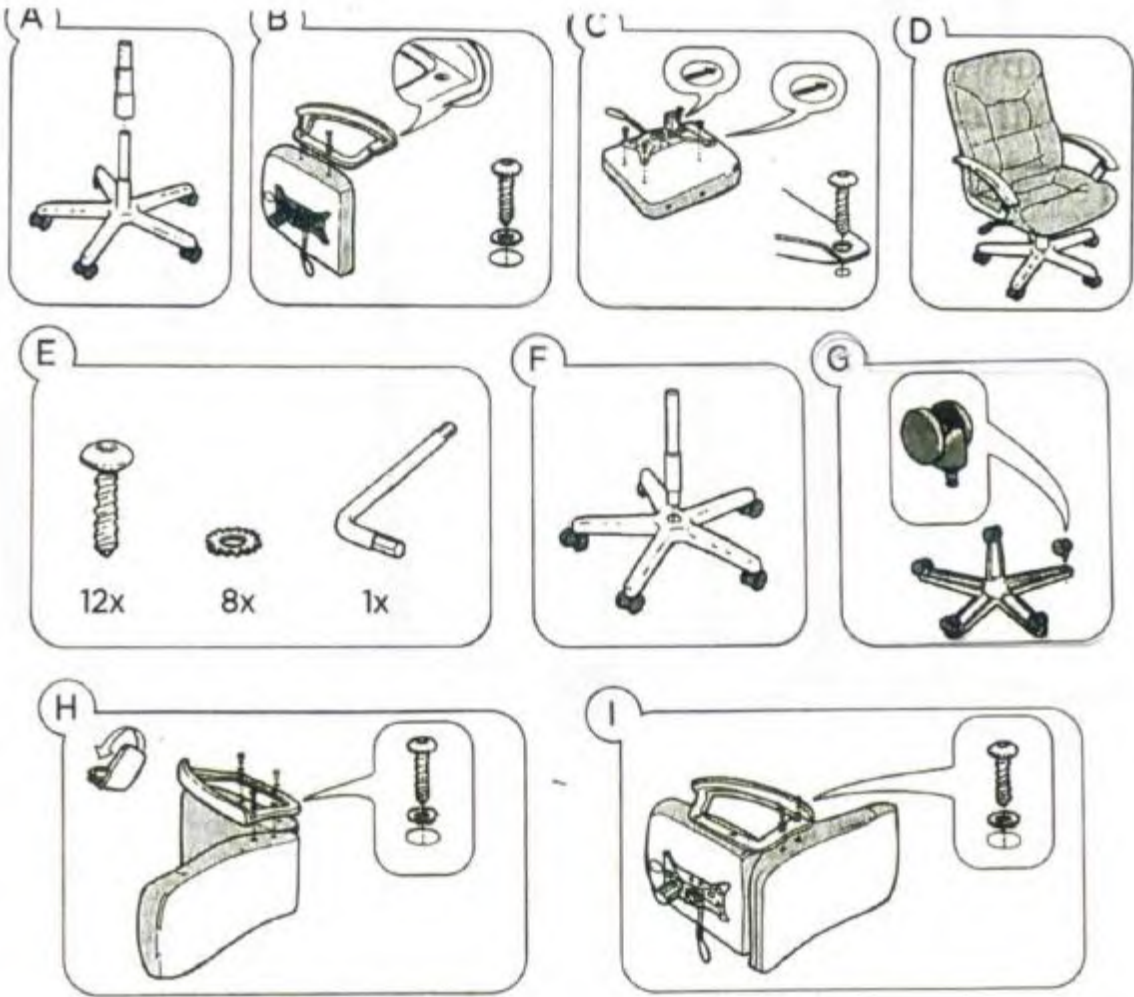

(9)

1.3 The school maintenance supervisor had to install a new grinding disc onto an angle grinder. Put the written instructions (A to G) in the correct order

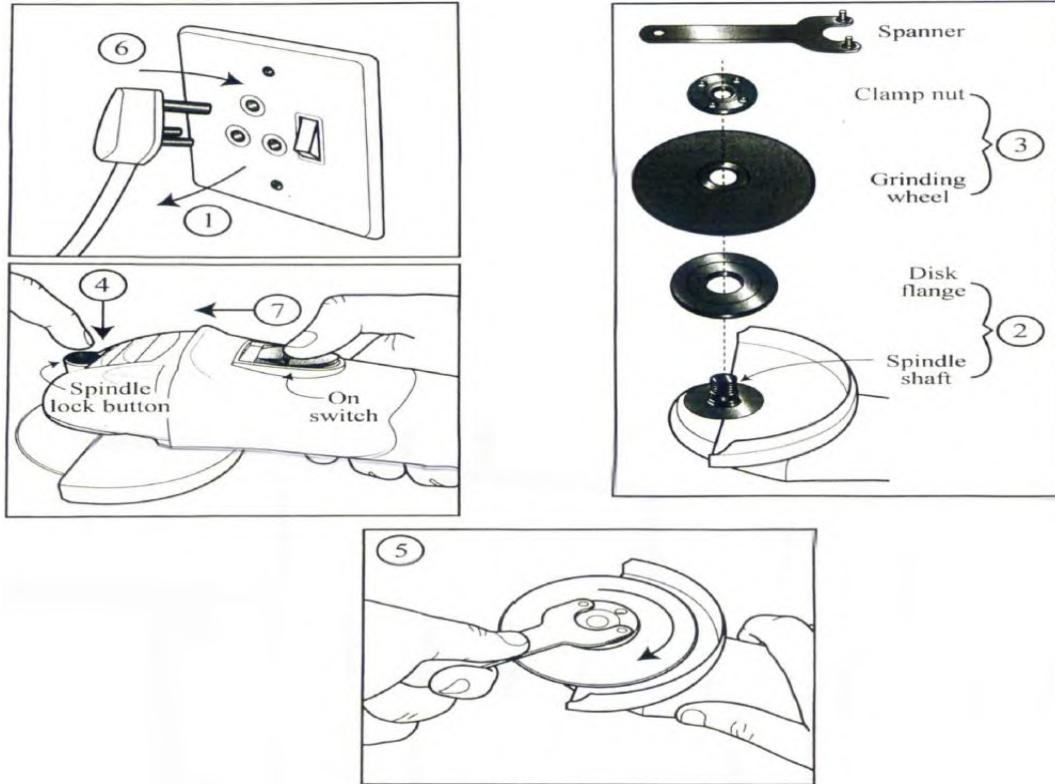

(7)

- A. Push down on the spindle lock button to lock the spindle before tightening the clamp nut with the spanner
- B. Put the disc flange on the grinder spindle shaft, and then put the grinding wheel on top
- C. Plug the three pin plug into the power socket
- D. Isolate and remove the angle grinder plug before assembling the grinding disc.
- E. Put the clamp nut on top of the grinding wheel and screw until tight onto the spindle shaft
- F. Once the spindle lock button is pressed, tighten the clamp nut onto the grinding disc with the spanner, turning clockwise
- G. Push the ON switch forward to test the grinder.

TOTAL

[20]

TOPIC: MODELS

SECTION: SOLVING PACKAGING PROBLEMS

3D SCALE MODELS

2D PICTURES (ITEM ARRANGEMENTS, ESTIMATE MATERIAL QUANTITIES)

OBJECTIVES:

The learners must be able to:

- The most cost-effective and convenient way to pack cans or boxes
- The packaging must be such that the space is optimally utilized

TERMINOLOGY

- Dimensions (length, width, height)
- Volume ,Area, Surface Area

NOTES

The teacher must address the following when dealing with packaging

- What aspects of Packaging are important?
- What shapes is packed?
- What shape is packed into?
- How is it packed?
- Optimal use of Space
- Cost efficiency

PACKAGING METHOD 1:

Length - wise: The LENGTH of the small box is packed along the LENGTH of the LARGE CONTAINER / BOX.

CALCULATION:

The number of small boxes that can be packed along length =
Length (ℓ) of large container / box \div length (ℓ_1) of small box

View of LENGTH of the large box:

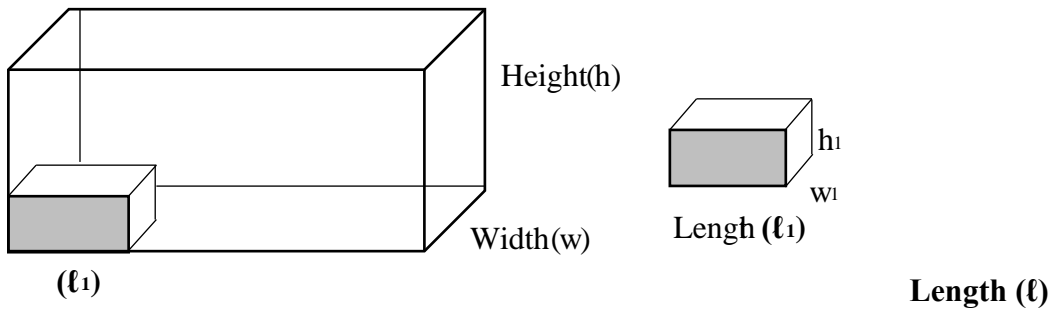

Width-wise: The WIDTH of the small box is packed along the WIDTH / BREADTH of the LARGE CONTAINER / BOX.

CALCULATION:

The number of small boxes that can be packed along WIDTH =
Width (w) of large container / box \div width (w₁) of the small box

View of the WIDTH / BREADTH of the large box

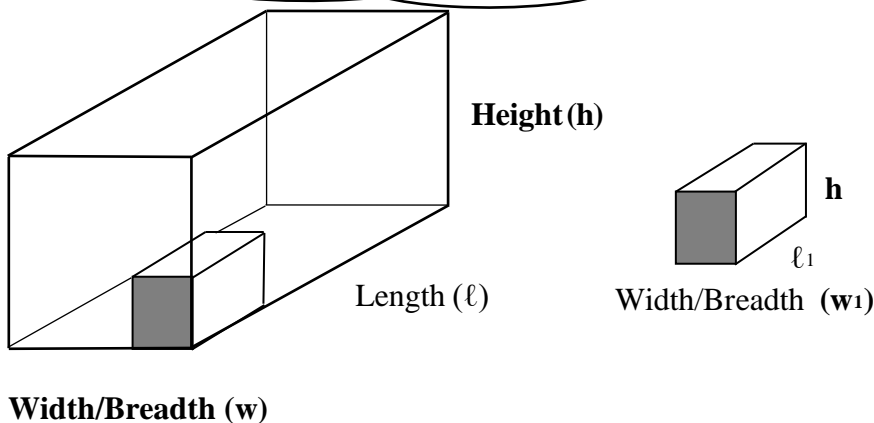

Height-wise: How many boxes can be packed along the HEIGHT of the BIG BOX / CONTAINER?

CALCULATION:

The number of small boxes that can be packed along the HEIGHT =
Height (h) of large container / box \div Height (h₁) of the box

- **TOTAL BOXES PACKED = number at length \times number at width \times number at height**
- **NUMBER OF BOXES PACKED ON BASIS = Number on length \times Number on width**

Packing a rectangular box in a rectangular container/large box:

PACKAGING METHOD 2:

Length-wise: The width of the small box is packed along the LENGTH of the large container / box.

CALCULATION:

The number of small boxes packed along the length = $\text{Length } (\ell) \text{ of large container} / \text{box} \div \text{width } (w_1) \text{ of the small box}$

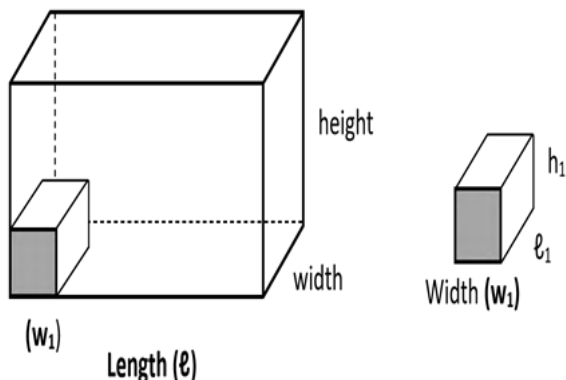

Width - wise: The LENGTH of the small box is packed along the WIDTH of the large container / box.

CALCULATION:

The number of small boxes that can be packed along the WIDTH = $\text{Width } (w) \text{ of large container} / \text{box} \div \text{length } (\ell_1) \text{ of the small box}$

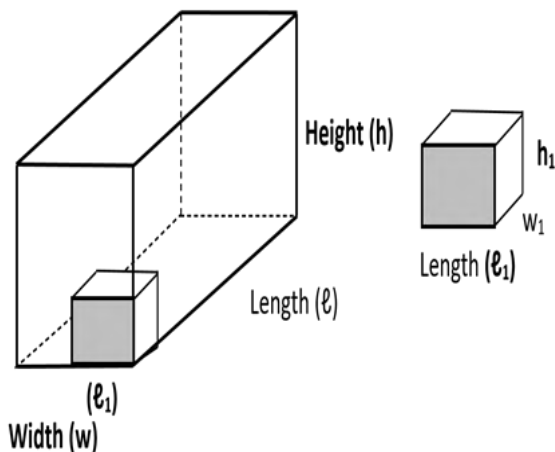

Height - wise: How many boxes can be packed along the height?

CALCULATION:

The number of small boxes that can be packed next to HEIGHT = $\text{Height } (h) \text{ of large container} / \text{box} \div \text{Height } (h_1) \text{ of the small box}$

What aspects of PACKAGING are important to us?

What is packed? Rectangular boxes and cylindrical cans/tins

What is it packed into? Rectangular Containers / Boxes

How is it packed? There are different packaging ways e.g. packaging methods 1 and 2 but optimal use of space and cost-effectiveness must also be taken into account.

OPTIMAL / MAXIMUM USE OF SPACE:

The boxes or cans should be packed in such a way that it fits the largest number of boxes/cans/tins in a container/box.

COST EFFICIENCY:

Packaging materials are expensive. The smallest container may need to be used for packaging of a certain number of boxes /tins /cans.

QUESTION 1

Marks

1.1

The small boxes must be packed in the big box.

(11)

Verify which of the following packaging options will be cost effective:

Option 1: The length of the small box along the length large box/container

Option 2: The width of the small box along box/container

Show all calculations to justify your answer

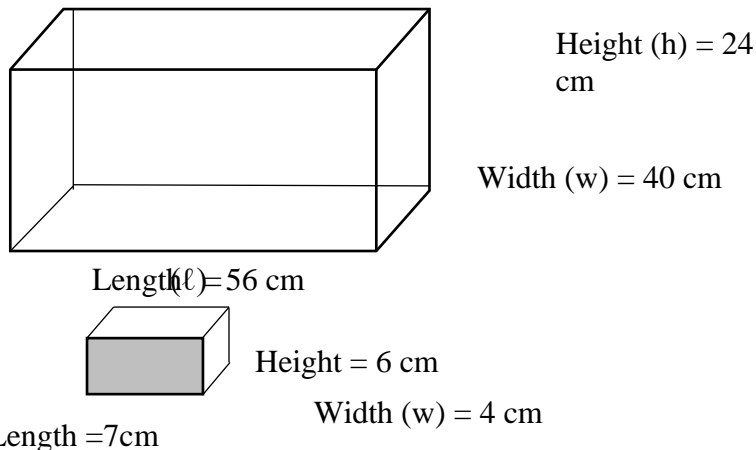
**SOLUTION:****OPTION 1:**

The length of the small box along the length of the large box / container

Length - wise:

The number of small boxes that can be packed along the LENGTH
= **length of large box** \div **length of small box**

$$= 56 \div 7 \checkmark M$$

$$= 8 \text{ boxes}$$

Width - wise:

The number of small boxes that can be packed along the WIDTH
= **width of large box** \div **width of small box**

$$= 40 \div 4 \checkmark M$$

$$= 10 \text{ boxes}$$

Height - wise:

The number of small boxes that can be packed along the HEIGHT
= **Height of big box** \div **Height of small box**

$$= 24 \div 6 \checkmark M$$

$$= 4 \text{ boxes}$$

TOTAL BOXES PACKED

= Number at length \times Number at width \times Number at height

$$= 8 \times 10 \times 4 \checkmark M$$

$$= 320 \text{ boxes} \checkmark CA$$

OPTION 2:

The width of the small box along the length of the large box / container

Length - wise:

The number of small boxes that can be packed along the LENGTH

$$= \text{length of large box} \div \text{width of small box}$$

$$= 56 \div 4 \checkmark M$$

$$= 14 \text{ boxes}$$

Width - wise:

The number of small boxes that can be packed along the WIDTH

$$= \text{width of large box} \div \text{length of small box}$$

$$= 40 \div 7 \checkmark M$$

$$= 5.7 = 5 \text{ boxes}$$

Height - wise:

The number of small boxes that can be packed along the HEIGHT

$$= \text{Height of big box} \div \text{Height of small box}$$

$$= 24 \div 6 \checkmark M$$

$$= 4 \text{ boxes}$$

TOTAL BOXES PACKED

= Number at length \times Number at width \times Number at height

$$= 14 \times 5 \times 4 \checkmark M$$

$$= 280 \text{ boxes} \checkmark CA$$

Conclusion

Option 1, more boxes can be packed and it will be more compact. $\checkmark J$

1.2

Determine how many cans/tins box. Show all calculations.

(7)

Box dimensions:

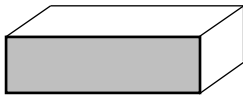

Height = 180 mm

Width = 43 cm

Length = 85 cm

Dimensions of the tin/can:

Radius = 3.5 cm

Height = 8.57 cm



$$\text{Diameter} = 3.5 \times 2 = 7 \text{ cm} \checkmark M$$

$$\text{Conversion: Height} = 180 \text{ mm} \div 10 = 18 \text{ cm} \checkmark C$$

Length - wise:

The number of cans/tins that can be packed along the LENGTH = Length of large box \div diameter of the tin

$$= 85 \div 7$$

$$= 12,14 \approx 12 \text{ cans/tins } \checkmark M$$

Width - wise:

The number of cans/tins that can be packed along the WIDTH = Width of large container / box \div diameter of the tin = $43 \div 7$

$$= 6,14 \approx 6 \text{ cans/tins } \checkmark M$$

Height - wise:

The number of cans/tins that can be packed next to HEIGHT

= Height of large container / box \div Height of the tin

$$= 18 \div 8.57$$

$$= 2,1 \approx 2 \text{ (cans/tins/layers) } \checkmark C$$

TOTAL CANS/TINS PACKED = number at length \times number at width \times number at height

$$= 12 \times 6 \times 2 \checkmark C$$

$$= 144 \text{ tins } \checkmark CA$$

TOTAL

[18]

ACTIVITIES

QUESTION 1

Marks

1.1

Calculate the number of small boxes that can be packed in the large box if it is packed along the container/box if the length (ℓ) of the small width(w) of the container / box.

(8)

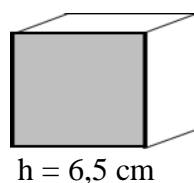
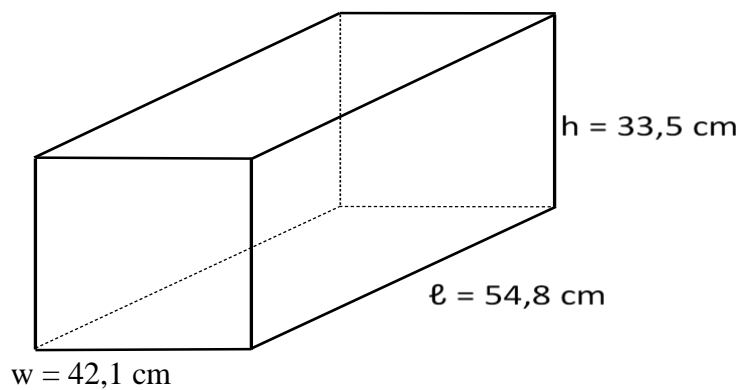

$$w = 87 \text{ mm}$$

$$\ell = 10,2 \text{ cm}$$

- 1.2 A box of 24 cans of Diet Coke is displayed. (5)



The radius of a can of Diet Coke is 3.5 cm. The cans are packed as in the picture. Calculate the minimum length and minimum width of the box to contain the 24 cans of Diet Coke.

- 1.3 Use the bookshelf and a book's dimensions to determine how many books can be packed into the TWO shelves if the books are packed in its width (w) along the length of the bookshelf (5)



[18]

QUESTION 2

The TVs are boxed and packed into shipping containers before they are exported. The boxes the TVs are packaged into have the dimensions $97 \text{ cm} \times 10 \text{ cm} \times 59 \text{ cm}$. The shipping containers have the dimensions $6 \text{ m} \times 2,4 \text{ m} \times 2,6 \text{ m}$.

An employee calculates how many

TVs will fit in one container.

His calculations are shown below:





$$\text{Volume of container} = 6 \times 2,4 \times 2,6$$

$$= 37,44 \text{ m}^3$$

$$\text{Volume of each TV box} = 0,97 \times 0,59 \times 0,1$$

$$= 0,05723 \text{ m}^3$$

$$\text{Number of TVs in container} = \text{Volume of container} \div \text{Volume of box}$$

$$= 37,44 \div 0,05723$$

$$= 654,2$$

$$\approx 654 \text{ TVs}$$

Neo, a Mathematical Literacy learner, recognises that the employee has made a common mistake in calculating the number of boxes that can fit.

2.1

Explain, in words, what the mistake is

(2)

2.2

Neo stated that 576 TVs can fit into this container if the boxes are packed in the following way as illustrated in the diagram below. By means of calculations, show whether he is correct or not.

(9)

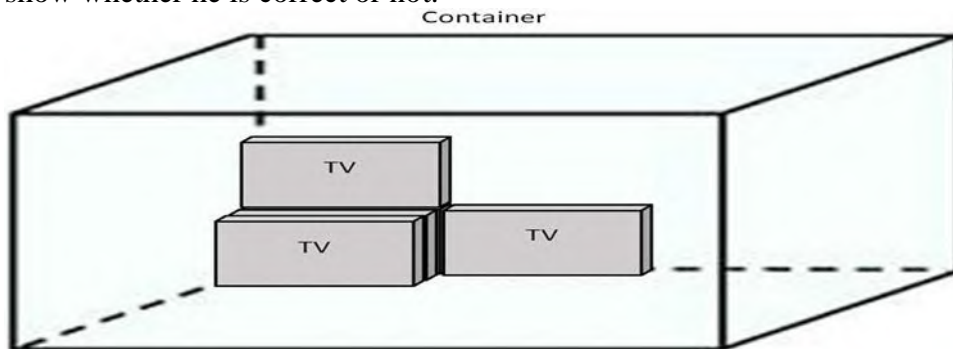

Note: The diagram is not drawn to scale and shows only a few of the boxes so that you may see how they are packed.

TOTAL

[11]

[29]

SECTION: PROBABILITY OF SIMPLE EVENT
 RELATIVE FREQUENCY AND THEORETICAL PROBABILITY
 COMPOUND EVENT

LESSON OBJECTIVES

At the end of the lesson the learner must be able to Interpretations and calculations involving scenarios involving probability. You should be able to see how probability applies in data tables, graphs and any possible way where it could be applied.

You need to be able to do the following:

Explore probability in scenarios that involve:

- Games with coins & dice
- Weather predictions



Work with expressions of probability in that you:

- Understand the difference between the terms: outcome and event.



- Recognise that probability can be expressed using a scale.



Understand that probability can be expressed in one of three ways:

- Fraction
- Decimal
- Percentage

Understand the difference between:

- Theoretical Probability
- Relative frequency (Experimental probability) Representing possible outcomes of events by using:
 - Tree diagrams
 - Two-way tables

KEY CONCEPTS/
 TERMINOLOGY/VOCABULARY

Certain – It will definitely happen
Very likely – It has a much greater chance of happening
Frequency - The number of times that something happens
Random - When something happens without being made to happen on purpose.
Trial - A test. Throwing a dice and tossing a coin are examples of a trial.

Fair - Treated equally, without having an advantage or disadvantage.

Theoretical probability - The calculated probability, not the actual result.

PRIOR-KNOWLEDGE/ BACKGROUND KNOWLEDGE

Learner must be able to explore the probability in scenarios involving :

- Games using coins and dice
- Weather predictions.

INTRODUCTION

Calculations involving probability are often confined to **mathematical calculations** primarily in the context of dice, coins and games. Although we may encounter situations involving probability and chance on a regular basis in daily life, it is very seldom that mathematical calculations are needed in order to make sense of those situations. E.g. **you don't need to be able to calculate the probability of winning a lottery to know that even though there is a chance of winning, that chance is very small.** What is more important, is understanding the concept of probability, together with a sense of whether an event is more- or less likely to take place.

For probability you need to have the following skills:

- Simplifying fractions
- Basic percentage calculations
- Conversions between fractions, percentages and decimal numbers.
- Interpreting data tables

EXAMPLES WITH SOLUTIONS

.1..

The Probability Scale:

Probability can be expressed in 3 ways:

- Common Fraction
- Decimal
- Percentage

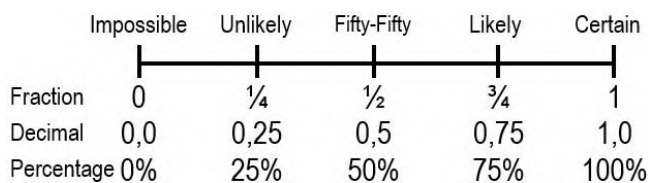

Decide where on the probability scale the following experiments would fall:

- 1.1 Flipping a coin.
 - Fifty-Fifty/Even
 - 1.2 Oranges growing on a banana tree.
 - Impossible
 - 1.3 The sun sets in the evening.
 - Certain
 - 1.4 Choosing a red ball in a bag with 2 white balls and 6 red balls.
 - likely
2. A private game reserve records the following number of animals: 236 springboks, 14 elephants, 2 rhinos and 37 zebras.

Calculate the probability using the formula to determine the first animal to be spotted is...

- 2.1 a rhino
 - $\frac{2}{289}$
- 2.2 a zebra
 - $\frac{37}{289}$
- 2.3 a giraffe
 - $\frac{0}{289}$
- 2.4 not a springbok
 - $\frac{53}{289}$

The sandwiches are made from an equal number of white (W), brown (B) and whole-wheat of leaves. The filling used for the sandwiches are egg (E) or fish (F), with (M) or without (N) mayonnaise.

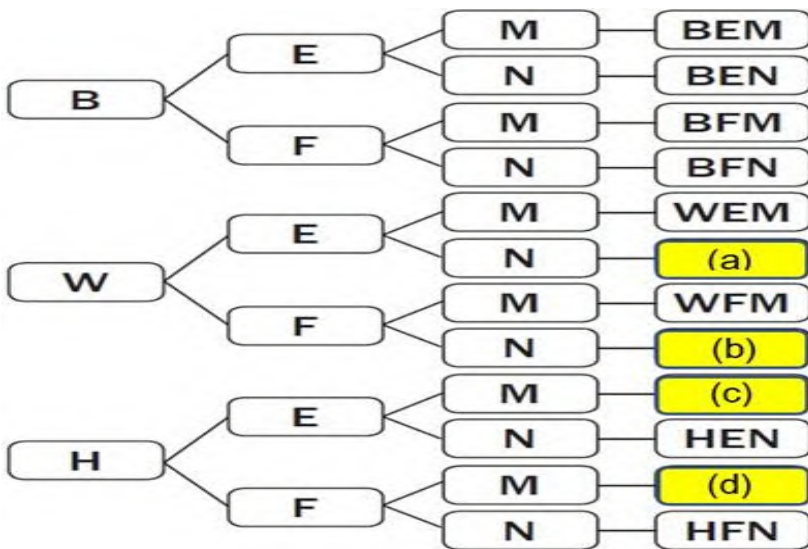

- 3.1 Explain what the outcome BEM represents on the tree diagram.
 - BEM means brown bread with egg and mayonnaise.
- 3.2 Complete the tree diagram[(a)-(d)]
 - (a) WEN 3 (b) WFN 3 (c) HEM 3 (d) HFM
- 3.3 Use the tree diagram to write down the probability in simplified form that a sandwich would
 - 3.3.1 Be a whole-wheat fish sandwich without mayonnaise.
 - $WFN = \frac{1}{12}$ or 0,08
 - 3.3.2 Not be a white bread sandwich.
 - 0,67 or 66,7 %

ACTIVITIES

ACTIVITY 1

1. Write down the chances of getting the outcomes in the following situations. Write your answers as decimals, percentages and common fractions. You must give all three.
 - 1.1 Getting any odd number when throwing a dice once.

1.2 Getting a 3 when throwing a dice with 8 faces.

1.3 Selecting a Jack from a deck of cards.

1.4 You take out a T-shirt (without looking!) from a pile which has 1 blue, 3 green and 2 purple T-shirts in it. What are the chances of taking out a purple T-shirt?

2. A simple prediction game involves a bag that contains two red balls and three green balls. The probability of a sequence of two balls being selected (first one ball and then a second ball) can be shown in the following tree diagram (Red ball = R, Green ball = G):

Situation 1

With each ball being drawn and replaced in the bag immediately:

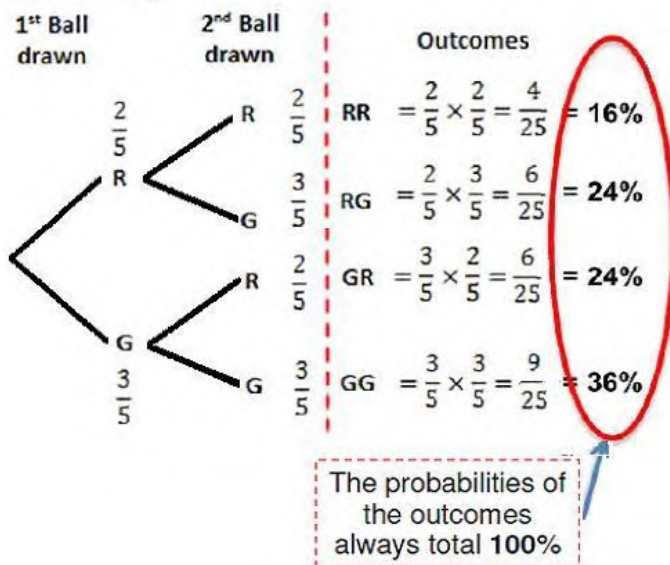

2.1 What is the probability that the first ball drawn is a red ball?





2.2 What is the probability that the second ball drawn is a red ball if the first ball was a red ball?

2.3 What is the probability that both balls are red?

2.4 What is the probability that at least one of the balls drawn is a green ball?

3. Celeste, a resident of Kimberley, studied the weather forecast below relating to the following day to determine whether it was necessary to take an umbrella to work.

HOURLY WEATHER FORECAST FOR KIMBERLEY – 12/03/2019

13:00	14:00	15:00	16:00	17:00
				
29°C	29°C	29°C	28°C	26°C
N	NNW	NNW	NNW	NW
☁ 20%	☁ 20%	☁ 20%	☁ 37%	☁ 64%

- 3.1 Determine the probability that it will rain when Celeste leaves work at 2:30 p.m.
 - 3.2 Determine the probability that the temperature increased from 13:00 to 17:00. Express your answer as a decimal number.
 - 3.3 Determine the probability that the temperature remained the same from 13:00 to 15:00. Express your answer as a percentage.
 - 3.4 Determine the probability that the wind blew in any westerly direction from 13:00 to 16:00. Express your answer as a fraction.
4. The following spinner has two ways to look at it: 1- the patterns; 2- the colours written on the spinner. If a person spins the spinner, what are the chances to:

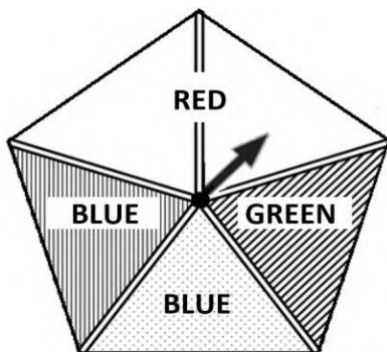

- 4.1 get the diagonal line pattern. Express your answer as a fraction.
- 4.2 get the white solid colour. Express your answer as a percentage.
- 4.3 get the colour blue that was written. Express your answer as a decimal fraction.
- 4.4 not get the dotted pattern. Express your answer as a percentage.

5. On the roulette wheel there are 18 red and 18 are black numbers. But there is an additional 0 that is green in colour.



5.1 What is the probability that the first ball lands on a red number? Express your answer as a decimal. Round your answer to 2 decimal places.

5.2 What is the probability that the first ball lands on a red number 19? Express your answer a fraction.

5.3 What is the probability that the second ball lands on a red number if the first ball landed on a red number? Express your answer as a decimal.

Luca has three options of getting to school. She can ride her bicycle, catch a taxi or wake up extra early to get a lift with her father. The weather plays a big role in her decision of how to get to school.

The probability of it being a sunny day is $\frac{3}{7}$ and the probability of it being a rainy day is $\frac{4}{7}$.

If it is a sunny day, the probability of Luca riding her bicycle to school is 60%, while the probability of her catching a taxi is 0%.

If it is a rainy day, the probability of Luca catching a taxi is 0,5, and the probability of her getting up early to get a lift with her father is 0,4.

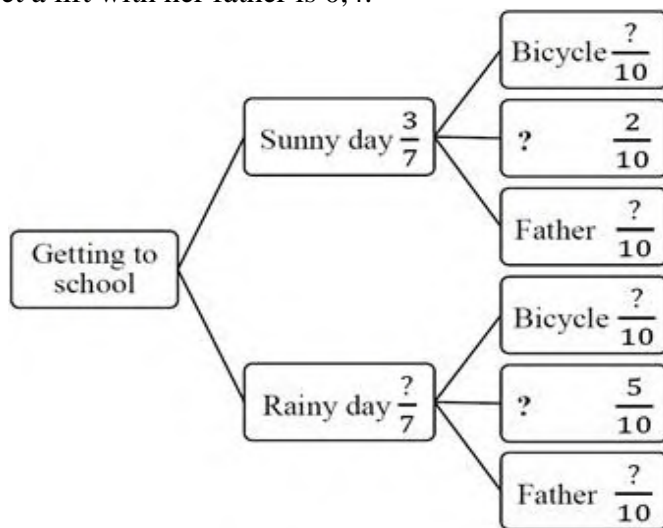

6.1 Complete the missing information by copying the tree diagram in your workbook.

6.2 Calculate the probability, as a fraction, that it will be a sunny day and that Luca will get up early to catch a lift with her father.

RESOURCES

Mind the Gap; Via Africa Study Guide; MATHEMATICAL LITERACY REVISION BOOKLET DBE; NSC Papers