



GAUTENG PROVINCE
EDUCATION
REPUBLIC OF SOUTH AFRICA

**JUNE EXAMINATION
GRADE 12**

2024

**PHYSICAL SCIENCES (PHYSICS)
(PAPER 1)**

Stanmorephysics.com

TIME: 3 hours

MARKS: 150

15 pages + 2 data sheets

PHYSICAL SCIENCES P1



C2841E

X05



INSTRUCTIONS AND INFORMATION

1. This question paper consists of 9 questions. Answer ALL the questions in the ANSWER BOOK.
2. Start EACH question on a NEW page in the ANSWER BOOK.
3. Number the answers correctly according to the numbering system used in this question paper.
4. Leave ONE line open between two subsections, e.g. between QUESTION 2.1 and QUESTION 2.2.
5. You may use a non-programmable calculator.
6. You may use appropriate mathematical instruments.
7. You are advised to use the attached DATA SHEETS.
8. Show ALL formulae and substitutions in ALL calculations.
9. Round-off your FINAL numerical answers to a minimum of TWO decimal places.
10. Give brief motivations, discussions, etc. where required.
11. Write neatly and legibly.



QUESTION 1: MULTIPLE-CHOICE QUESTIONS

Various options are provided as possible answers to the following questions. Each question has only ONE correct answer. Choose the answer and write only the letter (A – D) next to the question numbers (1.1 to 1.10) in the ANSWER BOOK, e.g. 1.11 E.

- 1.1 Two forces, F_1 and F_2 , are applied on a box lying on a frictionless surface as shown below. The magnitude of F_1 is greater than the magnitude of F_2 .



The box will ...

- A accelerate towards the left.
 - B accelerate towards the right.
 - C move at a constant speed towards the right.
 - D move at a constant speed towards the left. (2)
- 1.2 A 5 kg iron shot putt and a 10 kg aluminium shot putt, with the same diameter, fall freely from a shelf that is 12 m above the ground. Ignore the effects of air friction.
- When the shot putts are 3 m above the ground, they have the same ...
- A momentum.
 - B acceleration.
 - C potential energy.
 - D kinetic energy. (2)
- 1.3 Two asteroids, **S** and **T**, having masses of **M** and **2M** respectively, are on course for a collision.

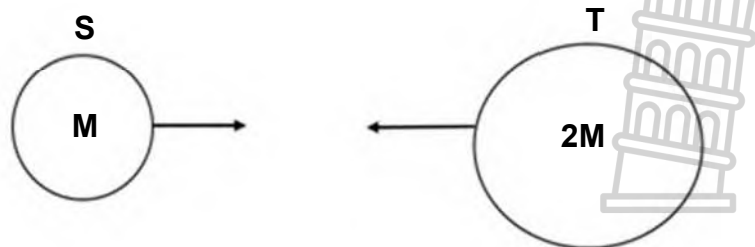

If the magnitude of the acceleration on asteroid **S** is **a**, then the magnitude of the acceleration on asteroid **T** is:

- A $\frac{1}{4} a$
- B $\frac{1}{2} a$
- C **a**
- D **2a** (2)

1.4 A sound source approaches a stationary observer at a CONSTANT VELOCITY. Which of the following describes the observed wavelength and frequency from the sound source as it approaches?

	OBSERVED WAVELENGTH	OBSERVED FREQUENCY
A	Greater than	Greater than
B	Less than	Less than
C	Greater than	Less than
D	Less than	Greater than

(2)

1.5 Two objects, m_1 and m_2 a distance r apart, experience a gravitational force F . The mass m_1 is now doubled and the distance is halved. The gravitational force between m_1 and m_2 is now:

- A $\frac{1}{8} F$
- B $\frac{1}{2} F$
- C F
- D $8F$

(2)

1.6 An object is thrown vertically downwards towards the ground from height h , with a velocity v . The object strikes the ground and bounces upwards. It is caught when it reaches its maximum height after the bounce.

Which of the following graphs for velocity versus time best represents the motion of the object?

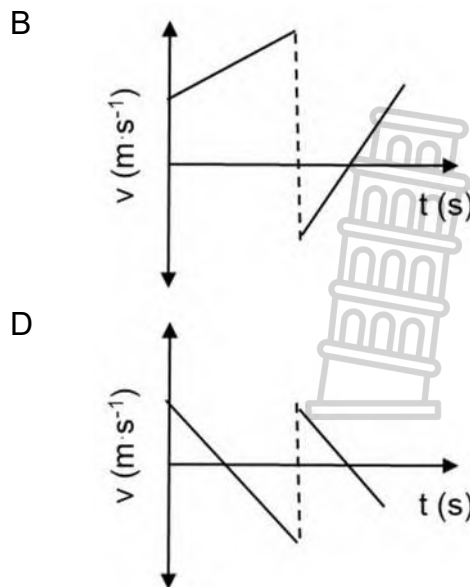
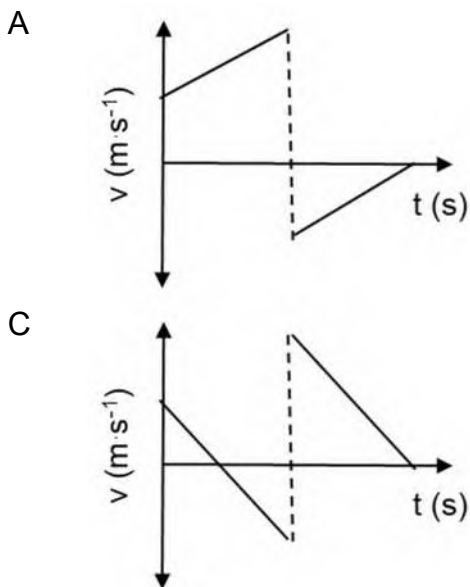

(2)

1.7 A crate is pulled up a slope.

Which of the forces will do zero work on the object?

- A Pulling force
- B Normal force
- C Frictional force
- D Gravitational force

(2)

1.8 Three identical spheres **X**, **Y** and **Z**, are placed together in a triangular arrangement so that each sphere touches the other. The three spheres are then moved back to their original positions.

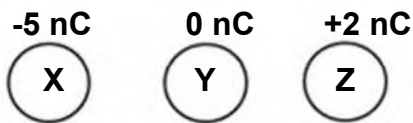

diagram 1

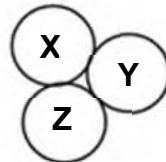

diagram 2

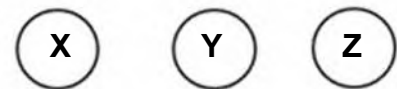

diagram 3

What is the charge on each sphere now? (diagram 3)

- A -1 nC
- B +1 nC
- C -2 nC
- D -3 nC

(2)

1.9 A positively charged object has ...

- A fewer electrons than neutrons.
- B fewer protons than neutrons.
- C fewer electrons than protons.
- D more protons than neutrons.

(2)

1.10 The minimum resistance that can be acquired from the connection of two 4Ω resistors is ...

- A 1Ω
- B 2Ω
- C 3Ω
- D 8Ω

(2)

[20]

QUESTION 2 (Start on a new page.)

Block **M**, 10 kg, is connected to block **m**, 2 kg, with a rope, **T**, of negligible mass, over a frictionless pulley. Both blocks are at rest. The slope makes an angle of 30° with the horizontal. Friction on the slope cannot be ignored.

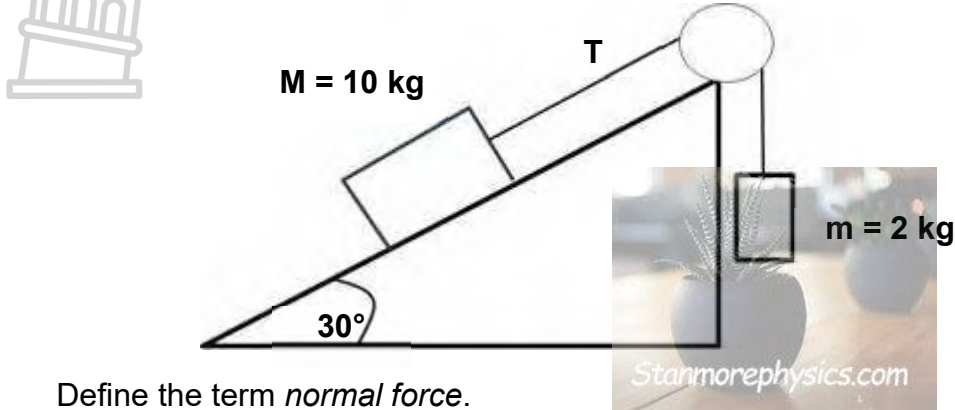

- 2.1 Define the term *normal force*. (2)
- 2.2 Draw a labelled, free-body diagram of all the forces acting on the 2 kg mass. (2)
- 2.3 Calculate the frictional force needed to keep the blocks at rest. (5)
- 2.4 The rope snaps above mass **m**, causing block **M** to slide down the slope, and block **m** to fall to the ground. The kinetic frictional force between the block and the slope is 25 N. Ignore the mass of the rope **T**.

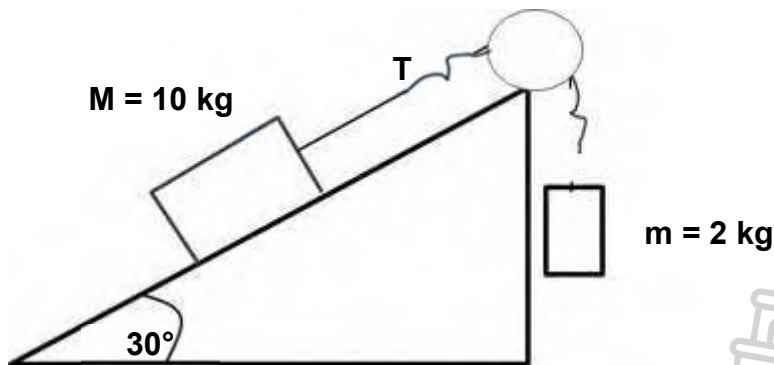

- 2.4.1 Draw a free-body diagram of all the forces acting on mass **M**. (3)
- 2.4.2 Calculate the magnitude of the acceleration of mass **M**. (4)
- 2.5 Block **m** takes 0,5 s to reach the ground.
- 2.5.1 Calculate the final velocity of block **m**. (3)
- 2.5.2 How would the final velocity of **m** be affected if the mass was doubled and it is dropped from the same height? Write only INCREASE, DECREASE or REMAIN THE SAME.

Explain the answer.

(3)
[22]

QUESTION 3 (Start on a new page.)

The Curiosity rover was dropped from 125 km above the surface of Mars. The mass of the Curiosity rover is 899 kg and the mass of Mars is $6,42 \times 10^{23}$ kg. The radius of Mars is 53,25% that of Earth.

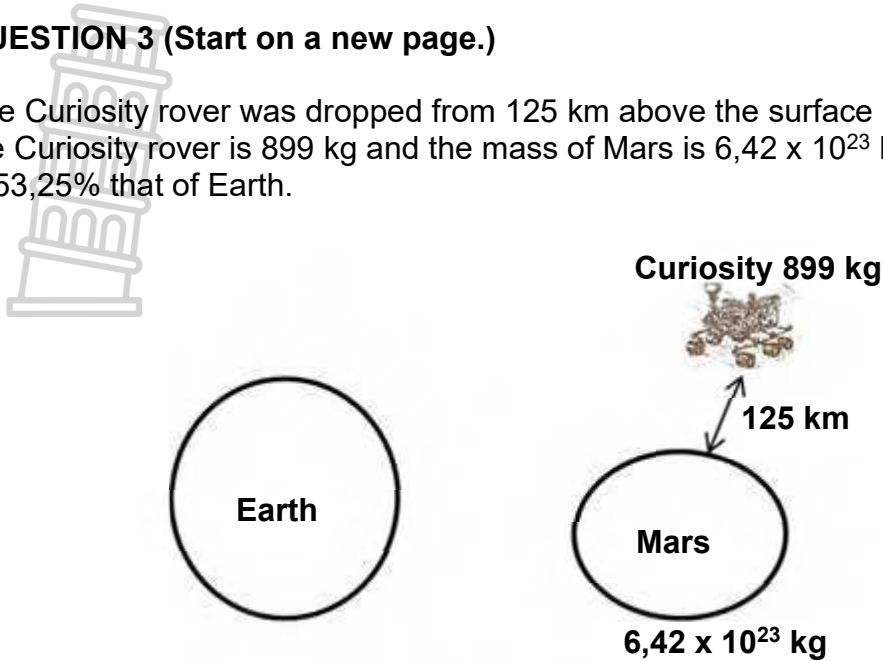

- 3.1 State Newton's Law of Universal Gravitation in words. (2)
- 3.2 Calculate the weight of the Curiosity on Earth. (2)
- 3.3 Calculate the gravitational acceleration on Mars. (4)
- 3.4 Would the mass of the Curiosity be different on Mars than on Earth? Choose from YES or NO.

Give a reason for the answer.

(2)
[10]



QUESTION 4 (Start on a new page.)

A learner standing at the bottom of a building, throws ball **A** vertically upwards at a speed of $11 \text{ m}\cdot\text{s}^{-1}$ and ball **A** reaches a maximum height **T**. After $0,72 \text{ s}$, another learner standing on the roof of the building throws ball **B** upwards. The two balls reach point **T** at the same time, as shown in the diagram below.

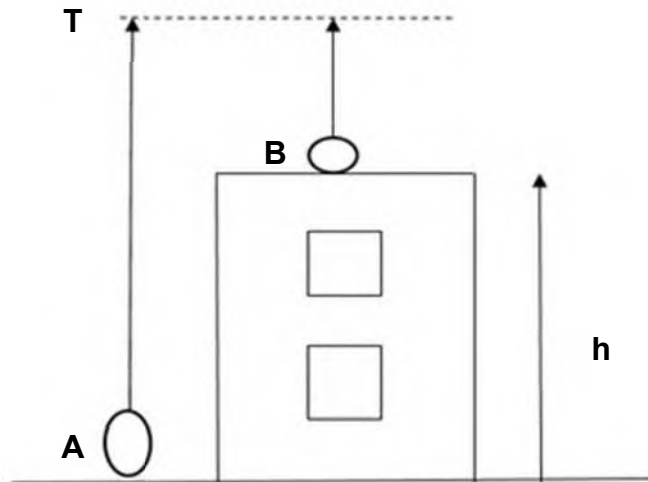

- 4.1 What is the difference between *free fall* and *projectile motion*? (2)
- 4.2 Calculate the:
- 4.2.1 Time taken by ball **A** to reach the maximum height at **T** (3)
- 4.2.2 Initial velocity of ball **B** (4)
- 4.2.3 Height, **h**, of the building (6)



- 4.3 The following position-time graph is given for the motion of the two balls, **A** and **B**, as described above. Study the graphs and answer the questions below.

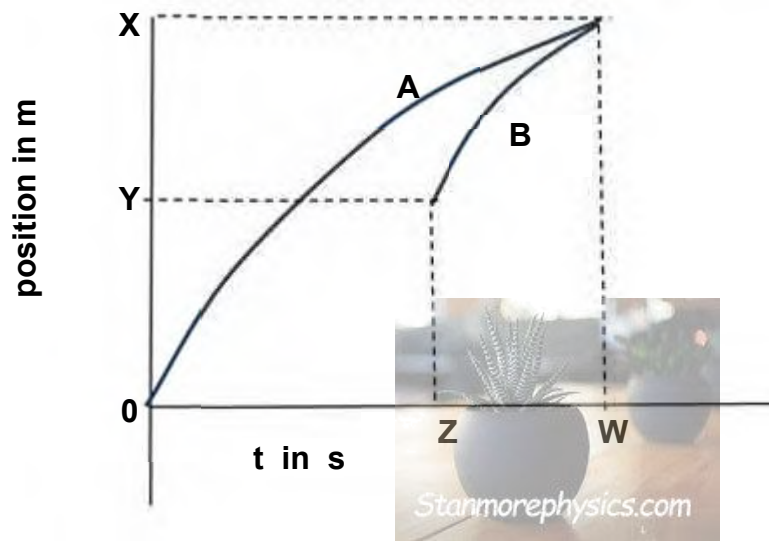

Write down the value and unit for:

- 4.3.1 X (1)
4.3.2 Y (1)
4.3.3 Z (1)
4.3.4 W (1)

[19]



QUESTION 5 (Start on a new page.)

- 5.1 A wrecking ball is used to demolish an old building by smashing into it. The wrecking ball has a mass of 950 kg and is suspended in the air with a second rope, 3,5 m above the ground. The ball is then released to smash into the building. At the lowest point of swing, the ball is at a height of h (1 m) above the ground. Ignore air friction.

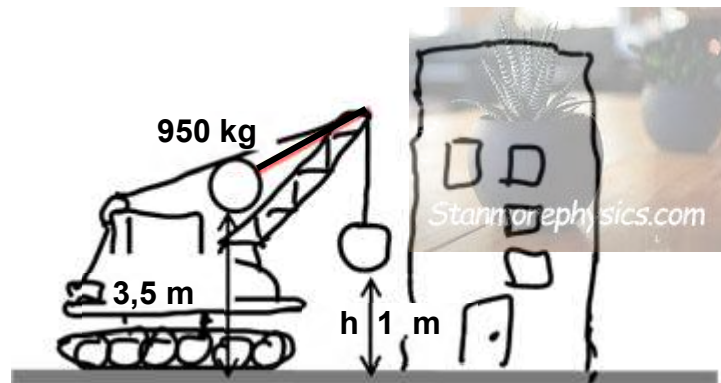

- 5.1.1 State the law of *conservation of mechanical energy*. (2)
- 5.1.2 The ball swings and hits the building at height h . Calculate the speed at which the ball hits the building using only energy principles. (4)
- 5.1.3 The ball hits the wall. It takes 0,1 s to stop, and then rebounds. Calculate the magnitude of the force with which the ball hits the wall. (3)
- 5.1.4 Write down the force that the wall exerts on the ball.
- Name and state the law in physics that is used to arrive at this conclusion. (3)



- 5.2 A Grade 12 learner, with a mass of 75 kg, is on a skateboard with a mass of 2 kg, which is moving at a constant velocity of $2 \text{ m}\cdot\text{s}^{-1}$ east over a frictionless surface. A ball, mass 500 g, moving at a speed of $v \text{ m}\cdot\text{s}^{-1}$ west, is thrown at the learner. The learner catches the ball. The final kinetic energy after this collision is 146 J.

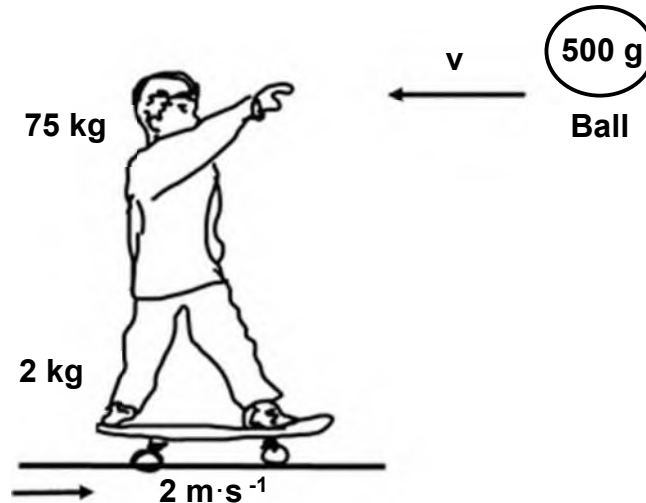

Calculate the initial speed of the ball.

(5)
[17]

QUESTION 6 (Start on a new page.)

An object with a mass of 85 kg is initially at rest on the ground. It is then pulled vertically upwards at a constant acceleration of $0,75 \text{ m}\cdot\text{s}^{-2}$ by means of a light, inextensible rope, as shown in the diagram below. Ignore air resistance, the mass of the rope or any rotational effects.

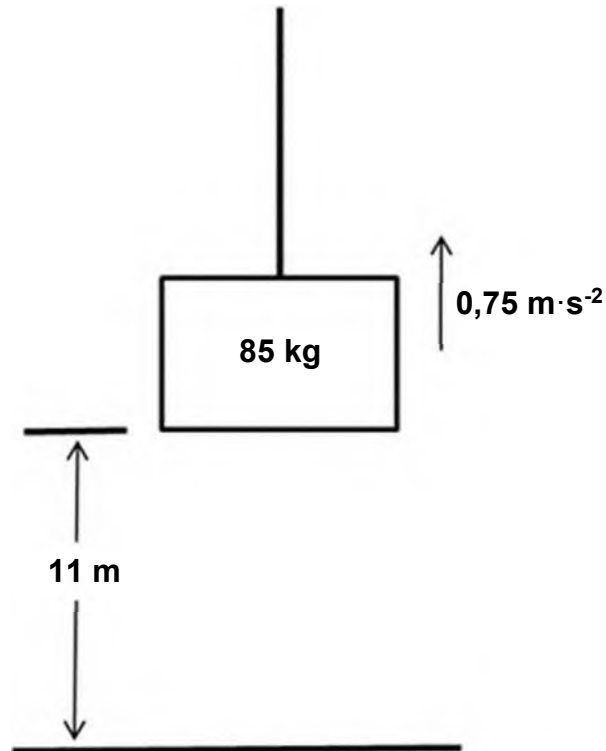

- 6.1 Draw a labelled, free-body diagram for the mass while it moves upward. (2)
- 6.2 Name the non-conservative force acting on the mass. (1)
- 6.3 Calculate the work done on the mass by the gravitational force when the mass has reached a height of 11 m. (3)
- 6.4 State the *work-energy theorem* in words. (2)
- 6.5 Use the work-energy theorem to calculate the speed of the mass when it is at a height of 11 m. (5)
- 6.6 A 30 kW motor is used to lift the mass of 85 kg to this height of 11 m. Calculate the percentage efficiency of this motor if it is working at maximum power. (6)

[19]

**QUESTION 7 (Start on a new page.)**

- 7.1 The siren of a rescue vehicle emits waves at a frequency of 360 Hz. The frequency of the sound as heard by a listener standing along the road is 405 Hz.
- 7.1.1 Define the *Doppler effect*. (2)
- 7.1.2 Was the rescue vehicle moving TOWARDS or AWAY FROM the listener?
Explain the answer, making specific reference to *frequency*, *wave fronts* and *wavelength*. (4)
- 7.1.3 Take the speed of sound in air to be $340 \text{ m}\cdot\text{s}^{-1}$. Calculate the speed at which the rescue vehicle was moving. (4)
- 7.2 The driver of the rescue vehicle continues at this speed past the stationary listener. What change(s), if any, would occur in the following?
Write down the values of:
- 7.2.1 The frequency of the siren as heard by the driver (1)
- 7.2.2 The frequency observed by the listener (1)
- 7.2.3 The speed of sound in the air (1)
- [13]**



QUESTION 8 (Start on a new page.)

Point **A** and point **B** are 0,04 m apart, as shown below. (The sketch is not drawn to scale.) Sphere **X** lies 0,01 m from point **A**. Sphere **X** has 1 238 electrons removed from the surface.

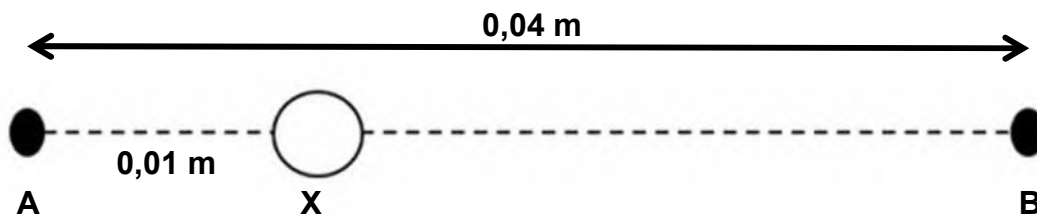

- 8.1 What is the nature of the charge on sphere **X**? Choose either POSITIVE or NEGATIVE. (1)
- 8.2 Calculate the magnitude of the charge on sphere **X**. (3)
- 8.3 Define the term *electric field*. (2)
- 8.4 Draw the net electric field pattern for two identical spheres with opposite charge. (3)
- 8.5 At what point, **A** or **B**, is the magnitude of the electric field, due to the charged sphere **X**, greater? Explain the answer. (3)
- 8.6 Calculate the electric field of sphere **X** at point **B** if sphere **X** is replaced with a charge of -2×10^{-9} C. (3)
- 8.7 A negative point charge **Y** with a charge of $-2,8$ nC is NOW placed at point **B**, and a point charge **Z** with a charge of $+3,2$ nC is placed at point **A**.
- 8.7.1 Draw a vector diagram to show the direction of the forces on charge **X** because of charges **Y** and **Z**. (2)
- 8.7.2 Calculate the net electrostatic force on sphere **X** because of charges **Y** and **Z**. (5)

[22]

QUESTION 9 (Start on a new page.)

A circuit diagram is set up as in the diagram below. Resistors R_1 , R_2 and R_3 are identical. Switches S_1 and S_2 are closed. Ignore all internal resistance.

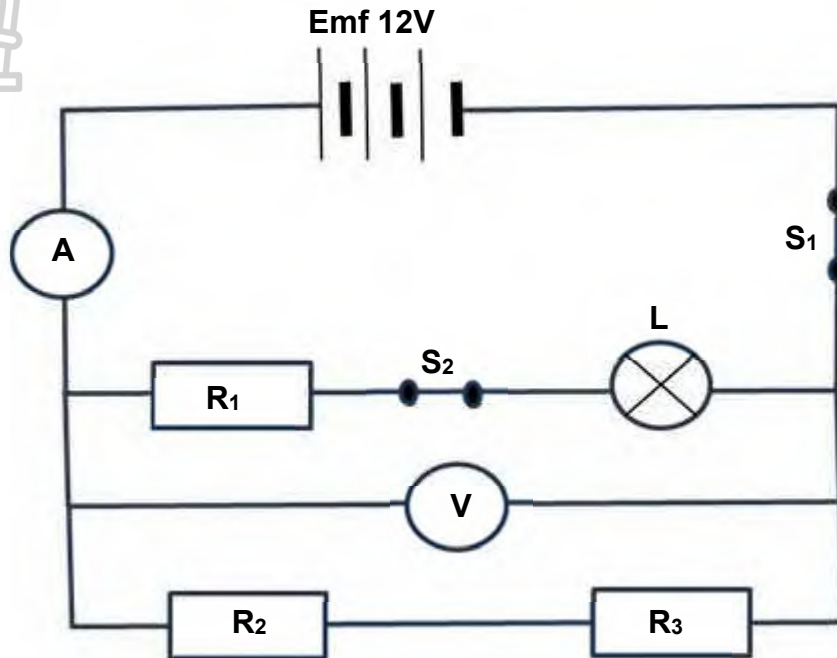

Use the diagram above to answer the following questions.

- 9.1 State *Ohm's law* in words. (2)
- 9.2 Name the component of a non-ohmic conductor in the diagram above. (1)
- 9.3 Write down the reading on the voltmeter with both switches closed. (1)
- 9.4 Switch S_2 is opened. Write down the reading on the voltmeter V . (1)
- 9.5 Switch S_2 is closed and switch S_1 is opened. Write down the reading on the voltmeter V . (1)
- 9.6 Switch S_2 is opened. How would this affect the ammeter reading?
Write only INCREASES, DECREASES or STAYS THE SAME. (1)
- 9.7 Both switches are closed. Resistor R_1 is removed. How would this affect the voltmeter reading?
Write only INCREASES, DECREASES or STAYS THE SAME. (1)

[8]**TOTAL: 150**

DATA FOR PHYSICAL SCIENCES GRADE 12
PAPER 1 (PHYSICS)

TABLE 1: PHYSICAL CONSTANTS

NAME	SYMBOL	VALUE
Acceleration due to gravity	g	$9,8 \text{ m}\cdot\text{s}^{-2}$
Universal gravitational constant	G	$6,67 \times 10^{-11} \text{ N}\cdot\text{m}^2\cdot\text{kg}^{-2}$
Speed of light in a vacuum	c	$3,0 \times 10^8 \text{ m}\cdot\text{s}^{-1}$
Planck's constant	h	$6,63 \times 10^{-34} \text{ J}\cdot\text{s}$
Coulomb's constant	k	$9,0 \times 10^9 \text{ N}\cdot\text{m}^2\cdot\text{C}^{-2}$
Charge on electron	e	$-1,6 \times 10^{-19} \text{ C}$
Electron mass	m_e	$9,11 \times 10^{-31} \text{ kg}$
Mass of the Earth	M	$5,98 \times 10^{24} \text{ kg}$
Radius of the Earth	R_E	$6,38 \times 10^6 \text{ m}$

TABLE 2: FORMULAE

MOTION

$v_f = v_i + a \Delta t$	$\Delta x = v_i \Delta t + \frac{1}{2} a \Delta t^2$ of $\Delta y = v_i \Delta t + \frac{1}{2} a \Delta t^2$
$v_f^2 = v_i^2 + 2a\Delta x$ of $v_f^2 = v_i^2 + 2a\Delta y$	$\Delta x = \left(\frac{v_i + v_f}{2} \right) \Delta t$ of $\Delta y = \left(\frac{v_i + v_f}{2} \right) \Delta t$

FORCE

$F_{\text{net}} = ma$	$p = mv$
$f_s^{\text{max}} = \mu_s N$	$f_k = \mu_k N$
$F_{\text{net}} \Delta t = \Delta p$ $\Delta p = mv_f - mv_i$	$w = mg$
$F = G \frac{m_1 m_2}{d^2}$ of $F = G \frac{m_1 m_2}{r^2}$	$g = G \frac{M}{d^2}$ of $g = G \frac{M}{r^2}$

WORK, ENERGY AND POWER

$W = F \Delta x \cos \theta$	$U = mgh$ or $E_p = mgh$
$K = \frac{1}{2} mv^2$ or $E_k = \frac{1}{2} mv^2$	$W_{\text{net}} = \Delta K$ or $W_{\text{net}} = \Delta E_k$ $\Delta K = K_f - K_i$ or $\Delta E_k = E_{kf} - E_{ki}$
$W_{\text{nc}} = \Delta K + \Delta U$ of $W_{\text{nc}} = \Delta E_k + \Delta E_p$	$P = \frac{W}{\Delta t}$
$P_{\text{ave}} = F v_{\text{ave}}$	

WAVES, SOUND AND LIGHT

$v = f \lambda$	$T = \frac{1}{f}$
$f_L = \frac{v \pm v_L}{v \pm v_s} f_s$	$E = hf$ or $E = h \frac{c}{\lambda}$
$E = W_0 + E_{k(\max)}$ or $E = W_0 + K_{\max}$ where $E = hf$ and $W_0 = hf_0$ and $E_{k(\max)} = \frac{1}{2} m v_{\max}^2$ or $K_{\max} = \frac{1}{2} m v_{\max}^2$	

ELECTROSTATICS

$F = \frac{kQ_1 Q_2}{r^2}$	$E = \frac{kQ}{r^2}$
$V = \frac{W}{q}$	$E = \frac{F}{q}$
$n = \frac{Q}{e}$ or $n = \frac{Q}{q_e}$	

ELECTRIC CIRCUITS

$R = \frac{V}{I}$	$\text{emf} (\epsilon) = I(R + r)$
$R_s = R_1 + R_2 + \dots$ $\frac{1}{R_p} = \frac{1}{R_1} + \frac{1}{R_2} + \dots$	$q = I \Delta t$
$W = Vq$ $W = VI \Delta t$ $W = I^2 R \Delta t$ $W = \frac{V^2 \Delta t}{R}$	$P = \frac{W}{\Delta t}$ $P = VI$ $P = I^2 R$ $P = \frac{V^2}{R}$

ALTERNATING CURRENT

$I_{\text{rms}} = \frac{I_{\text{max}}}{\sqrt{2}}$	$P_{\text{ave}} = V_{\text{rms}} I_{\text{rms}}$
$V_{\text{rms}} = \frac{V_{\text{max}}}{\sqrt{2}}$	$P_{\text{ave}} = I_{\text{rms}}^2 R$
	$P_{\text{ave}} = \frac{V_{\text{rms}}^2}{R}$

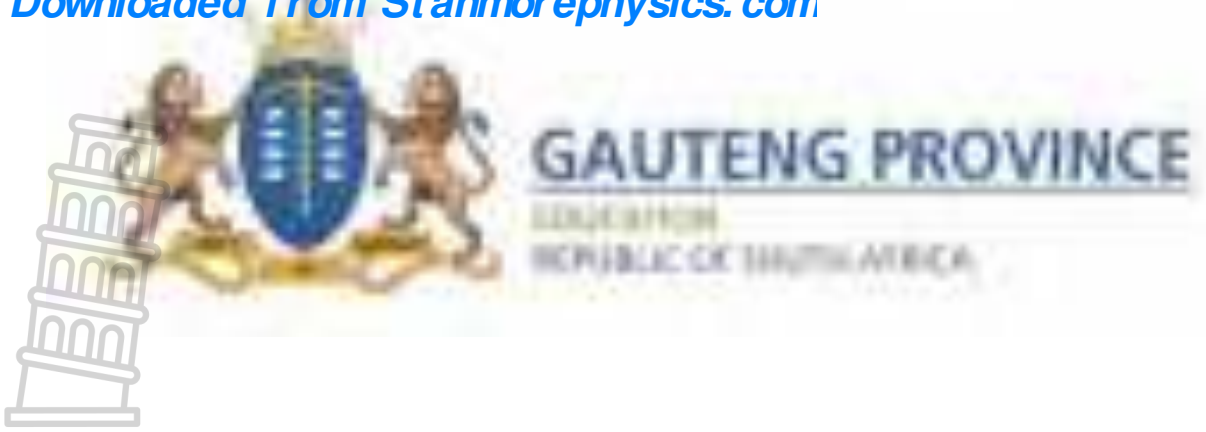

**JUNE EXAMINATION
JUNIE EKSAMEN**

GRADE/GRAAD 12

2024

**MARKING GUIDELINES/
NASIENRIGLYNE**

**PHYSICAL SCIENCES: PHYSICS/
FISIESE WETENSKAPPE: FISIKA**

(PAPER/VRAESTEL 1)

13 pages/bladsye

QUESTION/VRAAG 1

- 1.1 B ✓✓ (2)
 - 1.2 B ✓✓ (2)
 - 1.3 B ✓✓ (2)
 - 1.4 D ✓✓ (2)
 - 1.5 D ✓✓ (2)
 - 1.6 A ✓✓ (2)
 - 1.7 B ✓✓ (2)
 - 1.8 A ✓✓ (2)
 - 1.9 C ✓✓ (2)
 - 1.10 B ✓✓ (2)
- [20]**

QUESTION/VRAAG 2

- 2.1 The force or the component of a force which a surface exerts on an object with which it is in contact, and which is perpendicular to the surface. ✓✓

Die krag of komponent van 'n krag wat 'n oppervlak op 'n voorwerp waarmee dit in kontak is, uitoefen en wat loodreg op die oppervlak is. (2)

Marking criteria/Nasienkriteria

If any of the underlined key words/phrases in the **correct context** is omitted deduct 1 mark./Indien enige van die onderstreepte sleutel woorde/frases in die **korrekte konteks** uitgelaat is, trek 1 punt af.

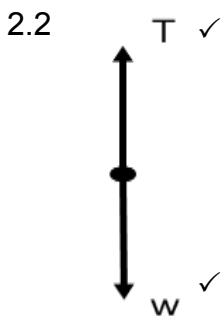

Accepted labels/Aanvaarde byskrifte	
w	F_g/F_w /weight/mg/gravitational force do not accept gravity F_g/F_w /gewig/gravitasiekrag moet nie gravitasie aanvaar nie.
T	F_T /tension F_T /spanning/spankrag
Deduct 1 mark for any additional force. Mark is given for both arrow and label. If everything is correct, but no arrows, deduct a mark	

(2)

Trek een punt af vir enige addisionele kragte. Punte word gegee vir beide pylpunt en byskrif. Indien alles korrek is, maar geen pyle nie, trek 'n punt af.

2.3 In x-direction for mass M: / In x-rigting vir massa M:

$$F_{\text{net}} = ma \quad \checkmark$$

$$T + f - w_{\parallel} = 0$$

Any one/Enige een

$$2(9,8) \checkmark + f - 10(9,8)\sin 30^\circ \checkmark = 0 \checkmark \quad \text{OR} \quad 2(9,8) \checkmark - f - 10(9,8)\sin 30^\circ \checkmark = 0 \checkmark$$

$$f = -2(9,8) + 10(9,8)\sin 30^\circ$$

$$= -19,6 + 49$$

$$= 29,4 \text{ N (up the slope/teen die helling op)} \checkmark$$

(5)

2.4 2.4.1

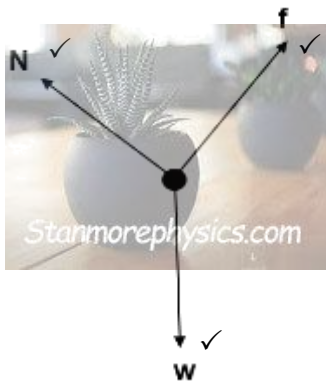

Accepted labels Aanvaarde byskrifte	
w	F_g/F_w /weight/mg/gravitational force F_g/F_w /gewig/mg/gravitasiekrag
f	F_{friction}/F_f /friction/ f_k F_{wrywing}/F_f /wrywing/ f_k
N	F_N /Normal force/Normaalkrag
	Deduct 1 mark for any additional force. Mark is given for both arrow and label
	DO NOT ACCEPT COMPONENTS IN FREE BODY DIAGRAM
	Trek 1 punt af vir addisionele kragte. Punte word gegee vir beide pyl en byskrif.
	MOET NIE KOMPONENTE AANVAAR IN DIE VRYLIGGAAMDIAGRAM NIE

(3)

2.4.2 $F_{\text{net}} = ma \quad \checkmark$

$$w_{\parallel} - f = ma$$

$$10(9,8)\sin 30^\circ - 25 \checkmark = 10 a \checkmark$$

$$a = 2,4 \text{ m}\cdot\text{s}^{-2} \checkmark$$

(4)

2.5 2.5.1 $v_f = v_i + a\Delta t \checkmark$

$$= 0 + (9,8)(0,5) \checkmark$$

$$v_f = 4,9 \text{ m}\cdot\text{s}^{-1} \text{ (down / afwaarts)} \checkmark$$

A learner can use the option of -9,8
The same answer will be obtained.

OR

$$F_{\text{net}} \Delta t = \Delta p \quad \checkmark$$

$$2(9,8)(0,5) = 2v_f - 2v_i \quad \checkmark$$

$$v_f = 4,9 \text{ m}\cdot\text{s}^{-1} \text{ (down / afwaarts)} \checkmark$$

(3)

2.5.2 REMAIN THE SAME/BLY DIESELFDE ✓

The object is moving under the force of gravity only ✓ and through the same height. ✓ That will have no effect on the final velocity.

OR

When using equations of motion and falling at gravitational acceleration only, the mass has no influence on the final velocity. The height will though.

Die voorwerp beweeg slegs onder die gravitasiekrag en deur dieselfde hoogte. Dit sal geen effek op die finale eindsnelheid hê nie.

OF

Wanneer bewegingsvergelings gebruik word en slegs teen gravitasieversnellings val, het die massa geen invloed op die finale eindsnelheid nie. Die hoogte sal wel.

(3)
[22]

QUESTION/VRAAG 3

- 3.1 Each body in the universe attracts every other body with a force that is directly proportional to the product of their masses ✓ and inversely proportional to the square of the distance between their centres. ✓

Elke liggaam in die heelal trek elke ander liggaam aan met 'n krag direk eweredig aan die produk van hul massas en omgekeerd eweredig aan die kwadraat van die afstand tussen hul middelpunte.

(2)

Marking criteria/Nasienkriteria

If any of the underlined key words/phrases in the **correct context** is omitted deduct 1 mark. / Indien enige van die onderstreepte sleutel woorde/frases in die **korrekte konteks** uitgelaat is, trek 1 punt af.

- 3.2 Weight/Gewig $w = ma$
 $= 899 (9,8) ✓$
 $= 8\,810,2 \text{ N} ✓$

(2)

- 3.3 $g = \frac{GM}{r^2} ✓$
 $= \frac{6,67 \times 10^{-11} (6,42 \times 10^{23})}{(0,5325 \times 6,38 \times 10^6)^2} ✓$
 $= 3,71 \text{ m} \cdot \text{s}^{-2} ✓$

The gravitational acceleration on Earth is $9,8 \text{ m} \cdot \text{s}^{-2}$ while on Mars it is $3,71 \text{ m} \cdot \text{s}^{-2}$. (range of 3,70 – 3,72)

Die gravitasieversnelling op Aarde is $9,8 \text{ m} \cdot \text{s}^{-2}$ terwyl dit op Mars $3,71 \text{ m} \cdot \text{s}^{-2}$ is. (gebied van 3,70 – 3,72)

(4)

3.4 No/Nee ✓

Mass represents the matter an object is made up of and will not differ, no matter where in the universe you are. ✓

OR

The mass will be the same on both planets.

Massa verteenwoordig die materie waaruit 'n voorwerp bestaan en wat nie sal verskil nie, ongeag waar in die heelal jy is.

OF

Die massa sal dieselfde wees op beide planete.

(2)
[10]4.1 Motion of an object is free fall. ✓ Beweging van 'n voorwerp.

Object given an initial velocity is projectile. ✓ 'n Voorwerp wat begin met 'n beginsnelheid.

OR

Accept if definitions are given. / Aanvaar indien definisies gegee word

OR

Free fall and projectile **motion** is the same. Vryval en projektiel**beweging** is dieselfde.

(2)

4.2 4.2.1 OPTION/OPSIE 1 (down as positive/af as positief)

$$v_f = v_i + a\Delta t \quad \checkmark$$

$$0 = (-11) + (9,8)\Delta t \quad \checkmark$$

$$\Delta t = 1,12 \text{ s} \quad \checkmark$$

OPTION/OPSIE 2 (up as positive/op as positief)

$$v_f = v_i + a\Delta t \quad \checkmark$$

$$0 = (11) + (-9,8)\Delta t \quad \checkmark$$

$$\Delta t = 1,12 \text{ s} \quad \checkmark$$

(3)

4.2.2 Positive marking from QUESTION 4.2.1

OPTION 1 down as positive/
Positiewe nasien vanaf VRAAG

4.2.1

OPSIE 1 af as positief

$$v_f = v_i + a\Delta t \quad \checkmark$$

$$0 = v_i + (9,8)(1,12 - 0,72) \quad \checkmark$$

$$0 = v_i + (9,8)(0,40)$$

$$v_i = 3,92 \text{ m}\cdot\text{s}^{-1} \quad \checkmark$$

upwards/opwaarts ✓

OPTION 2 down as negative/OPSIE 2 af as negatief

$$v_f = v_i + a\Delta t \quad \checkmark$$

$$0 = v_i + (-9,8)(1,12 - 0,72) \quad \checkmark$$

$$v_i = 3,92 \text{ m}\cdot\text{s}^{-1} \quad \checkmark$$

upwards/opwaarts ✓

(4)

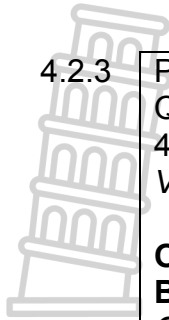

<p>4.2.3 Positive marking from QUESTION 4.2.1 and 4.2.2./Positiewe nasien vanaf VRAAG 4.2.1 en 4.2.2.</p> <p>OPTION 1 (down as positive) Ball A height above the ground: <i>OPSIE 1</i> (af as positief) Bal A hoogte bo die grond</p> $v_f^2 = v_i^2 + 2a\Delta y \quad \checkmark$ $0 = (-11)^2 + 2(9,8)\Delta y \quad \checkmark$ $\Delta y = 6,17 \text{ m} \quad \checkmark$ <p>Ball B height above the building/ Bal B hoogte bo die gebou:</p> $v_f^2 = v_i^2 + 2a\Delta y$ $0 = (-3,92)^2 + 2(9,8)\Delta y \quad \checkmark$ $\Delta y = 0,784 \text{ m}$	<p>Positive marking from 4.2.1 and 4.2.2./Positiewe nasien vanaf VRAAG 4.2.1 en 4.2.2.</p> <p>OPTION 2 (upwards positive) Ball A height above the ground/ <i>OPSIE 2</i> (op as positief) Bal A hoogte bo die grond</p> $v_f^2 = v_i^2 + 2a\Delta y \quad \checkmark$ $0 = (11)^2 + 2(-9,8)\Delta y \quad \checkmark$ $\Delta y = 6,17 \text{ m}$ <p>Ball B height above the building/ Bal B hoogte bo die gebou:</p> $v_f^2 = v_i^2 + 2a\Delta y$ $0 = (3,92)^2 + 2(-9,8)\Delta y \quad \checkmark$ $\Delta y = 0,784 \text{ m}$
<p>Height of building/Hoogte van die gebou:</p> <p style="text-align: center;">✓</p> $\text{Height/Hoogte} = 6,17 - 0,784$ $= 5,39 \text{ m (5,388 m)} \quad \checkmark$	<p>Height of building/Hoogte van die gebou:</p> <p style="text-align: center;">✓</p> $\text{Height/Hoogte} = 6,17 - 0,784$ $= 5,39 \text{ m} \quad \checkmark$
<p>OPTION/OPSIE 3 Ball A above the ground/ Bal A bo die grond:</p> $\Delta x = \left(\frac{v_f + v_i}{2}\right)\Delta t \quad \checkmark$ $\Delta x_A = \left(\frac{0 + 11}{2}\right) \times (1,12) \quad \checkmark$ $\Delta x = 6,16 \text{ m}$ <p>Ball B above the building/ Bal B bo die gebou:</p> $\Delta x = \left(\frac{v_f + v_i}{2}\right)\Delta t \quad \checkmark$ $\Delta x_B = \left(\frac{0 + 3,92}{2}\right) (0,4) \quad \checkmark$ $\Delta x = 0,784 \text{ m}$ <p>Height of building/Hoogte van die gebou:</p> <p style="text-align: center;">✓</p> $\text{Height/Hoogte} = 6,16 - 0,784$ $= 5,38 \text{ m (5,376 m)} \quad \checkmark$	<p>OPTION/OPSIE 4 Ball A above the ground/ Bal A bo die grond:</p> $\Delta x = v_i\Delta t + \frac{1}{2}a\Delta t^2 \quad \checkmark$ $\Delta x_A = 11 \times 1,12$ $+ \frac{1}{2}(-9,8) (1,12)^2 \quad \checkmark$ $\Delta x_A = 6,17 \text{ m}$ <p>Ball B above the building/ Bal B bo die gebou:</p> $\Delta x = v_i\Delta t + \frac{1}{2}a\Delta t^2 \quad \checkmark$ $\Delta x_B = 3,92 \times 0,4 + \checkmark$ $\frac{1}{2}(-9,8) (0,4)^2$ $\Delta x_B = 0,784 \text{ m}$ <p>Height of building/Hoogte van die gebou:</p> <p style="text-align: center;">✓</p> $\text{Height/Hoogte} = 6,17 - 0,784$ $= 5,39 \text{ m (5,386 m)} \quad \checkmark$

(6)

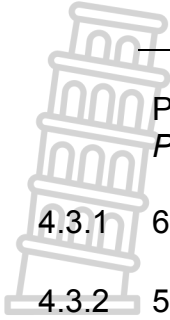

Positive marking from QUESTION 4.2 for answers of QUESTION 4.3/
Positiewe nasien van VRAAG 4.2 vir antwoorde van VRAAG 4.3

- 4.3 4.3.1 6,16 m ✓ (1)
- 4.3.2 5,38 m ✓ (1)
- 4.3.3 0,72 s ✓ (1)
- 4.3.4 1,12 s ✓ (1)
- [19]

QUESTION/VRAAG 5

- 5.1 5.1.1 The total mechanical energy (sum of gravitational potential energy and kinetic energy) in an isolated system remains constant. ✓✓

Die totale meganiese energie (som van gravitasie-potensiële energie en kinetiese energie) in 'n geïsoleerde sisteem bly konstant. (2)

Marking criteria/Nasienkriteria

If any of the underlined key words/phrases in the **correct context** is omitted deduct /If momentum is mentioned 0/2

1 mark./Indien enige van die onderstreepte sleutel woorde/frases in die **korrekte konteks** uitgelaat is, trek 1 punt af.

Indien momentum genoem word 0/2

5.1.2 OPTION/OPSIE 1:

$$E_{\text{mech } i} = E_{\text{mech } f} \quad \checkmark$$

$$\frac{1}{2}m_x v_{xi}^2 + m_x g h_x = \frac{1}{2}m_x v_{xf}^2 + m_x g h_h$$

$$0 + 950(9,8)(3,5) \checkmark = \frac{1}{2}(950)(v^2) + 950(9,8)(1) \quad \checkmark$$

$$v = 7 \text{ m} \cdot \text{s}^{-1} \quad \checkmark$$

Any one/Enige een

OPTION/OPSIE 2:

$$E_{\text{mech } i} = E_{\text{mech } f} \quad \checkmark$$

$$\frac{1}{2}m_x v_{xi}^2 + m_x g h_x = \frac{1}{2}m_x v_{xf}^2 + m_x g h_h$$

$$0 + 950(9,8)(3,5-1) \checkmark = \frac{1}{2}(950)(v^2) + 950(9,8)(0) \quad \checkmark$$

$$v = 7 \text{ m} \cdot \text{s}^{-1} \quad \checkmark$$

Any one/Enige een



OPTION 3/OPSIE 3

$$W_{nc} = \Delta E_k + \Delta E_p \quad \checkmark$$

$$0 = \left(\frac{1}{2} m_x v_{xf}^2 - \frac{1}{2} m_x v_{xi}^2 \right) + (m_x g h_h - m_x g h_x)$$

$$0 = \left(\frac{1}{2} (950)(v^2) - 0 \right) \checkmark + (950(9,8)(1) - 950(9,8)(3,5)) \checkmark$$

$$v = 7 \text{ m} \cdot \text{s}^{-1} \quad \checkmark$$

Any one/Enige een

(4)

5.1.3 Positive marking from QUESTION 5.1.2/Positiewe nasien vanaf VRAAG 5.1.2

$$F_{net} \Delta t = m \Delta v \quad \checkmark$$

$$F_{net}(0,1) = (950)(0 - 7) \quad \checkmark$$

$$F_{net} = -66\,500 \text{ N}$$

$$F_{net} = 66\,500 \text{ N} \quad \checkmark$$

OR

$$v_f = v_i + a \Delta t$$

$$0 = 7 + a(0,1)$$

$$a = -70 \text{ m} \cdot \text{s}^{-2}$$

$$F_{net} = ma \quad \checkmark$$

$$= 950(-70) \quad \checkmark$$

$$= -66\,500 \text{ N}$$

$$= 66\,500 \text{ N} \quad \checkmark$$

(3)

5.1.4 Positive marking from 5.1.3/positiewe nasien vanaf 5.1.3

66 500 N to the left/west/na links/wes \checkmark OR F_{ball} on wall

Newton's third law. \checkmark When object A exerts a force on object B, object B SIMULTANEOUSLY exerts an oppositely directed force of equal magnitude on object A. \checkmark

Newton se derde wet. Wanneer voorwerp A 'n krag op voorwerp B uitoefen, sal voorwerp B GELYKTYDIG 'n krag van gelyke grootte en in die teenoorgestelde rigting op voorwerp A uitoefen. \checkmark

(3)



5.2



$$E_k \text{ after} = \frac{1}{2}mv^2$$

$$146 = \frac{1}{2}(75 + 2 + 0,5)v^2 \checkmark$$

$$v = 1,94 \text{ m} \cdot \text{s}^{-1}$$

$$\Sigma p_{\text{before}} = \Sigma p_{\text{after}} \checkmark$$

$$m_{\text{learner}} v_{\text{learner } i} + m_{\text{ball}} v_{\text{ball } i} = (m_{\text{learner}} + m_{\text{ball}}) v_f \quad \left. \vphantom{m_{\text{learner}} v_{\text{learner } i}} \right\}$$

$$(75+2)(2) + 0,5(v) \checkmark = 77,5(1,94) \checkmark$$

$$v = -7,3$$

$$v_{\text{ball } i} = 7,3 \text{ m} \cdot \text{s}^{-1} \checkmark$$

Any one/Enige een

OR $m_1 v_1 + m_2 v_2 = (m_1 + m_2) v_f$

Range 7,13 – 7,3

(5)
[17]

QUESTION/VRAAG 6

6.1



Accepted labels/Aanvaarde byskrifte	
W	F_g/F_w /weight/mg/gravitational force F_g/F_w /gewig/mg/gravitasiekrag
T	F_T /tension F_T /spanning/spankrag
	Deduct 1 mark for any additional force. Mark is given for both arrow and label. If everything is correct, but no arrows, deduct a mark
	Trek een punt af vir enige addisionele kragte. Punte word gegee vir beide pylpunt en byskrif. Indien alles korrek is, maar geen pyle nie, trek 'n punt af.

(2)

6.2 Tension/Spanning \checkmark

(1)

6.3 OPTION/OPSIE 1:

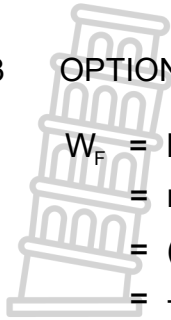

$$\begin{aligned}
 W_F &= F\Delta x \cos\theta \\
 &= mg\Delta x \cos\theta \quad \checkmark \\
 &= (85)(9,8)(11)\cos 180^\circ \quad \checkmark \\
 &= -9\,163 \text{ J} \quad \checkmark
 \end{aligned}$$

Any one/Enige een

OPTION/OPSIE 2:

$$\begin{aligned}
 W_w &= -\Delta E_p \\
 &= -(mgh - 0) \quad \checkmark \\
 &= -(85)(9,8)(11) \quad \checkmark \\
 &= -9\,163 \text{ J} \quad \checkmark
 \end{aligned}$$

Any one/Enige een

(3)

6.4 The net work done on an object is equal to the change in the object's kinetic energy. $\checkmark\checkmark$ (2 or 0)**OR**

The work done on an object by a net force is equal to the change in the object's kinetic energy.

*Die netto arbeid verrig op 'n voorwerp is gelyk aan die verandering in kinetiese energie van die voorwerp.***OF***Die arbeid verrig op die voorwerp deur 'n netto krag is gelyk aan die verandering in kinetiese energie van die voorwerp.*

(2)

6.5

$$\begin{aligned}
 W_{\text{net}} &= \Delta K \quad \checkmark \\
 F_{\text{net}}\Delta x \cos\theta &= \frac{1}{2}mv_f^2 - \frac{1}{2}mv_i^2 \\
 ma\Delta x \cos\theta &= \frac{1}{2}(85)v_f^2 - 0 \quad \checkmark \\
 (85)(0,75)(11)\checkmark \cos 0^\circ \checkmark &= 42,5v_f^2 \\
 v_f &= 4,06 \text{ m}\cdot\text{s}^{-1} \quad \checkmark
 \end{aligned}$$

Any one/Enige een



(5)

6.6 OPTION 1/OPSIE 1

$$v_f = v_i + a\Delta t$$

$$4,06 = 0 + (0,75)\Delta t \checkmark$$

$$t = 5,41 \text{ s}$$

Positive marking from QUESTION 6.3 for Work done by gravitational force./Positiewe nasien vanaf VRAAG 6.3 vir arbeid verrig deur gravitasiekrag.

$$W_{\text{net}} = \Delta E_k$$

$$-9163 + W_{\text{motor}} = \frac{1}{2}(85)(4,06^2 - 0^2) \checkmark$$

$$W_{\text{motor}} = 9\,863,55 \text{ J}$$

$$P = \frac{W}{t} \checkmark$$

$$= \frac{9\,863,55}{5,41} \checkmark$$

$$= 1\,823,21 \text{ W}$$

$$\% \text{ efficiency} = \frac{1\,823,21}{30\,000} \times 100 \checkmark$$

$$= 6,08\% \checkmark$$

OPTION 2/OPSIE 2

$$F_{\text{net}} + w = F_{\text{motor}}$$

$$85(0,75) + 85(9,8) \checkmark = F_{\text{motor}}$$

$$F_{\text{motor}} = 896,75 \text{ N}$$

$$P_{\text{ave}} = Fv_{\text{ave}} \checkmark$$

$$= (896,75) \checkmark \frac{0+4,06}{2} \checkmark$$

$$= 1\,820,4 \text{ W}$$

$$\% \text{ efficiency} = \frac{1\,820,4}{30\,000} \times 100 \checkmark$$

$$= 6,07\% \checkmark$$

(6)
[19]

QUESTION/VRAAG 7

- 7.1 7.1.1 The change in frequency (or pitch) of the sound detected by a listener, because the sound source and the listener have different velocities relative to the medium of sound propagation. ✓✓

Die verandering in frekwensie (of toonhoogte) van die klank waargeneem deur 'n luisteraar omdat die klankbron en die luisteraar verskillende snelhede relatief tot die medium waarin die klank voortgeplant word, het.

OR/OF

An (apparent) change in (observed/detected) frequency/pitch as a result of the relative motion between a source and an observer (listener).

'n (Skynbare) verandering in (waargenome) frekwensie/toonhoogte as gevolg van die relatiewe beweging tussen die bron en 'n waarnemer/luisteraar.

Marking criteria/Nasienkriteria

If any of the underlined key words/phrases in the **correct context** is omitted deduct

1 mark./Indien enige van die onderstreepte sleutel woorde/frases in die **korrekte konteks** uitgelaat is, trek 1 punt af.

(2)

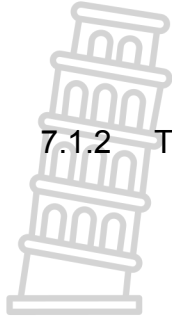

7.1.2 Towards/Na ✓

- The apparent frequency was higher/bigger ✓
- The wave fronts were closer together ✓ and
- The wavelength was shorter/smaller. ✓

- Die skynbare frekwensie was hoër,
- Die golffronte was nader aan mekaar en
- Die golflengte was korter.

(4)

7.1.3

$$f_L = \frac{v \pm v_L}{v \pm v_s} f_s \checkmark$$

$$405 \checkmark = \frac{340}{340 - v_s} 360 \checkmark$$

$$v_s = 37,78 \text{ m} \cdot \text{s}^{-1} \checkmark$$

(4)

7.2 7.2.1 360 (Hz) ✓

(1)

7.2.2 Less than/Minder as 360 (Hz) ✓ OR < 360 (Hz)

Any value less than 360 given is accepted. / Enige waarde minder as 360 word aanvaar.

(1)

7.2.3 340 (m·s⁻¹) ✓

(1)

[13]**QUESTION/VRAAG 8**

8.1 Positive/Positief ✓

(1)

8.2

$$n = \frac{Q}{e} \checkmark$$

$$\text{or } n = \frac{Q}{q_e}$$

$$1238 = \frac{Q}{1,6 \times 10^{-19}} \checkmark$$

$$Q = 1,981 \times 10^{-16} \text{ C} \checkmark$$

NOTE: do not penalize if -1,6 is substituted, but answer must be positive.

NOTA: moenie penaliseer indien -1,6 vervang, maar antwoord moet positief wees.

(3)

8.3 An electric field is a region of space in which an electric charge experiences a force. ✓✓ (2 or 0)

'n Elektriese veld is 'n area of gebied waarin 'n elektriese lading 'n krag sal ondervind. (2 of 0)

(2)

8.4

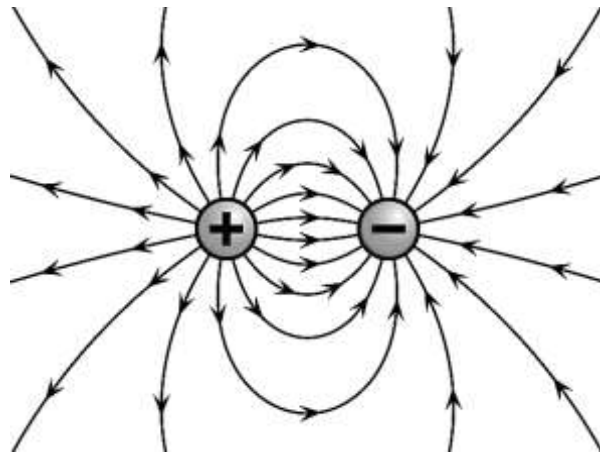

Criteria for sketch/Kriteria vir skets	Marks/ Punte
Correct direction of electric field – away from positive and towards negative. Do not penalize if + and – are not indicated. <i>/Korrekte rigting van elektriese veld – weg van positief en na negatief. Moenie penaliseer indien + en – nie aangedui word nie.</i>	✓
Correct shape of the electric field lines between, above and on the outside of the charges. Lines curve in the correct direction. <i>/Korrekte vorm van die elektriese veldlyne, tussen, bo en aan die buitekant van die ladings. Lyne buig in die regte rigting.</i>	✓
No field lines crossing each other. Field lines touch the charge, start at an angle perpendicular to the charge, do not go inside the charge. <i>/Geen veldlyne wat mekaar kruis nie. Veldlyne raak aan die ladings, begin by 'n hoek loodreg op die lading, gaan nie binne die lading nie.</i>	✓

8.5 A ✓

The field is strongest closest ✓ to the charged sphere. Point A is closer to sphere X than point B. The electric field is inversely proportional to the distance squared. OR $E \propto \frac{1}{r^2}$ ✓/

Die veld is die sterkste, naaste aan die gelaaiete sfeer. Punt A is nader aan sfeer X as punt B. Die elektriese veld is omgekeerd eweredig aan die afstand kwadraat. OF $E \propto \frac{1}{r^2}$

(3)

8.6

$$\begin{aligned}
 E &= \frac{kQ_x}{r^2} \quad \checkmark \\
 &= \frac{9 \times 10^9 (2 \times 10^{-9})}{(0,03)^2} \quad \checkmark \\
 &= 20\,000 \text{ N} \cdot \text{C}^{-1} \text{ left / links } \quad \checkmark
 \end{aligned}$$

(3)

8.7 8.7.1

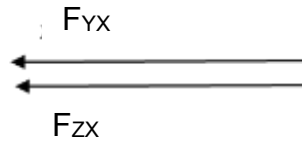

Marking criteria/Nasienkriteria:	Marks/Punte
Line and arrow with label//Lyn en pyl met byskrif	✓
Line and arrow with label//Lyn en pyl met byskrif	✓

(2)

8.7.2 **Marking criteria/Nasienriglyne**

- Correct formula for Coulombs law/Korrekte formule vir Coulomb wet
- Correct substitution for F_{YX} /Korrekte vervanging vir F_{YX}
- Correct substitution for F_{ZX} /Korrekte vervanging vir F_{ZX}
- Addition of forces/Optel van kragte
- Correct final answer/Korrekte finale antwoord

$$\begin{aligned}
 F_{\text{net}} &= \frac{kQ_Y Q_X}{r^2} + \frac{kQ_Z Q_X}{r^2} \quad \checkmark \\
 &= \frac{9 \times 10^9 (2,8 \times 10^{-9})(2 \times 10^{-9})}{(0,03)^2} \checkmark + \checkmark \frac{(9 \times 10^9)(3,2 \times 10^{-9})(2 \times 10^{-9})}{(0,01)^2} \checkmark \\
 &= 6,32 \times 10^{-4} \text{ N} \quad \checkmark
 \end{aligned}$$

(5)
[22]

QUESTION/VRAAG 9

9.1 **Marking criteria/Nasienkriteria**

If any of the underlined key words/phrases in the **correct context** is omitted, deduct 1 mark.//Indien enige van die onderstreepte sleutel woorde/frases in die **korrekte konteks** uitgelaat is, trek 1 punt af.

The potential difference across a conductor is directly proportional to the current in the conductor at constant temperature. ✓✓

Die potensiaalverskil oor 'n geleier is direk eweredig aan die stroom in die geleier by konstante temperatuur.

(2)

9.2 Lamp ✓ or bulb/gloeilamp of lamp

(1)

9.3 12 V ✓

(1)

9.4 12 V ✓

(1)

9.5 0 V ✓

(1)

9.6 Stays the same/Bly dieselfde ✓

(1)

9.7 Stays the same/Bly dieselfde ✓

(1)

[8]

TOTAL/TOTAAL: 150