



education

Department of
Education
FREE STATE PROVINCE



MARKS: 100

TIME: 2 HOURS

INSTRUCTIONS

1. This paper consists of TWO sections and TWELVE questions.
SECTION A: 20 marks
SECTION B: 80 marks
2. Number ALL your answers correctly according to the numbering system used in this question paper.
3. In the case of calculations, show ALL steps.
4. Round answers to TWO decimal places, where applicable.
5. Write neatly and legibly.
6. SKIP A LINE between sub-questions e.g., 4.1.1 and 4.1.2.



This question paper consists of 16 pages.

SECTION A

QUESTION 1

Various options are provided as possible answers to the following questions. Choose the answer and write only the letter (A – D) next to the question number (1.1 – 1.10), e.g., 1.11 B.

1.1 A force is defined as ...

- A a push or a pull
- B a pull, not a push.
- C a push, not a pull.
- D neither a push nor a pull. (1)

Use the following diagrams to answer questions 1.2 AND 1.3.

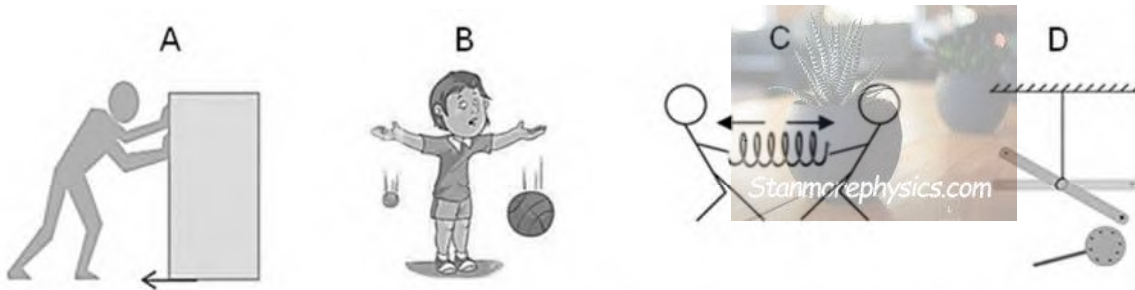

<https://www.sciencefacts.net/contact-and-non-contact-forces.html>

1.2 Which diagram illustrates a tension force?

- A A
- B B
- C C
- D D (1)

1.3 Which diagrams illustrate contact forces?

- A A and B
- B B and C
- C C and D
- D A and C (1)



1.4 Identify the force-pair when the soccer player's foot hits the ball.



<https://www.clipartmax.com/so/kicking-soccer-ball-clip-art/>

- A Force of the ground on the ball; Force of the ball on the ground.
- B Force of the foot on the ball; Force of the ball on the foot.
- C Force of the earth on the ball; Force of the ball on the earth.
- D Weight downwards; Normal force upwards. (1)

1.5 An electrical component which converts chemical energy into electrical energy.

- A Resistor
- B Buzzer
- C Bulb
- D Cell (1)

1.6 The function of a resistor in an electric circuit.

- A To provide energy for the current to flow.
- B To control the flow of current.
- C To measure the strength of the current.
- D To open or close a circuit. (1)

1.7 A series circuit ...

- A is a circuit in which the bulbs are connected in parallel.
- B provides more than one pathway for the current to flow through.
- C provides only one pathway for the current to flow through.
- D divides the current between the resistors. (1)

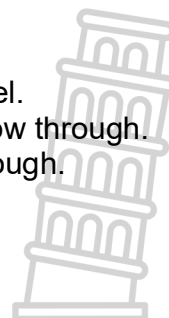

1.8 Two identical bulbs are connected in parallel in the circuit, shown below.

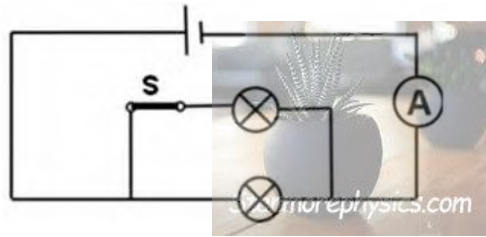

What will happen to the ammeter reading when switch S is opened?

- A The reading will not be affected.
- B The reading will increase (become higher).
- C The reading will decrease (become lower).
- D The reading will be 0 A. (1)

1.9 Which one of the following circuit components measures potential difference?

- A
- B
- C
- D (1)

1.10 Identical light bulbs and cells are used in the following circuits. In which circuit will the light bulb glow the brightest?

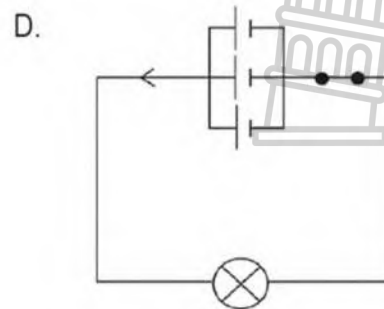
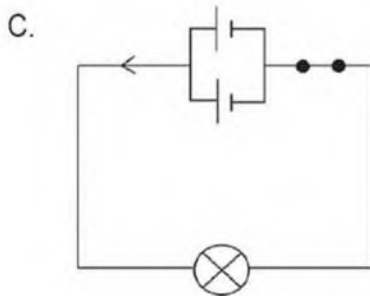
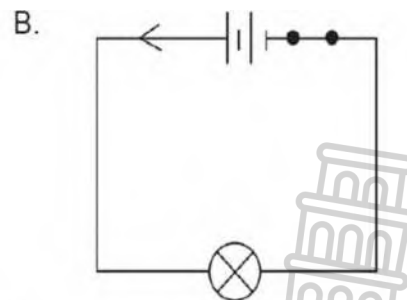
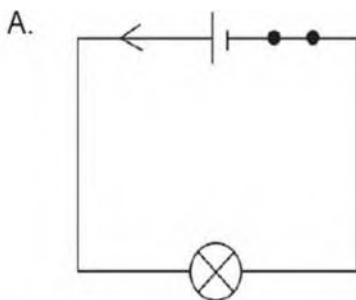

(1)
[10]

QUESTION 2

Give the SCIENTIFIC TERM (CORRECT WORD) for each of the following descriptions. Write ONLY the correct word next to the question number (2.1 – 2.5) in your answer book.

- 2.1 The rate of electrical energy supply. (1)
 - 2.2 The name of the nuclear power station near Cape Town. (1)
 - 2.3 The type of electricity generated by falling water. (1)
 - 2.4 The device used to step down or step up the voltage. (1)
 - 2.5 The green-and-yellow wire in a three-pin plug. (1)
- [5]**

QUESTION 3

Choose a word from COLUMN B that matches the description in COLUMN A. Write only the letter (A – J) next to the question number (3.1 – 3.5) in your answer book.

COLUMN A		COLUMN B	
3.1	The layer of the atmosphere where weather occurs.	A	Crust
3.2	The layer of the earth which consists of magma (molten rock).	B	Troposphere
3.3	Molten (liquid) rock which comes out of a volcano.	C	Magma
3.4	Earth's interconnected web of life, including all living organisms and their environments.	D	Ecosystem
3.5	A sedimentary rock.	E	Mantle
		F	Stratosphere
		G	Lava
		H	Biosphere
		I	Sandstone
		J	Granite

[5]

TOTAL SECTION A: 20

SECTION B

QUESTION 4

4.1 The diagrams below illustrate magnetic force, gravitational force, and electrostatic force.

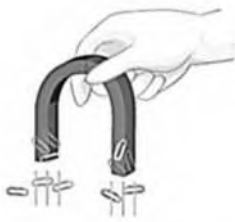
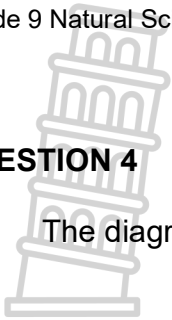

Magnetic Force



Gravitational Force



Electrostatic Force

<https://www.geeksforgeeks.org/contact-and-non-contact-forces/>

- 4.1.1 Explain why all these forces are classified as field forces or non-contact forces. (1)
- 4.1.2 What should the paper clips be made of to be attracted by the magnet? (1)
- 4.1.3 The balloon used to demonstrate the electrostatic force of attraction between the balloon and the pieces of paper, has an EXCESS OF ELECTRONS.
 - (a) What is the charge on the balloon? Choose between POSITIVE, NEGATIVE or NEUTRAL. (1)
 - (b) What is the charge on the pieces of paper? Choose between POSITIVE, NEGATIVE or NEUTRAL. (1)
- 4.2 An investigation is conducted to determine the relationship between the mass of an object and the gravitational force exerted by the Earth on it.
 - 4.2.1 Name the two factors that affect the magnitude (strength) of gravitational force. (2)
 - 4.2.2 Explain the difference between MASS and WEIGHT. (2)

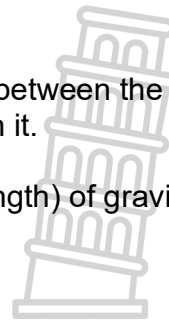

4.2.3 The mass and the weight of different objects are measured. The following graph represents the results of the investigation:

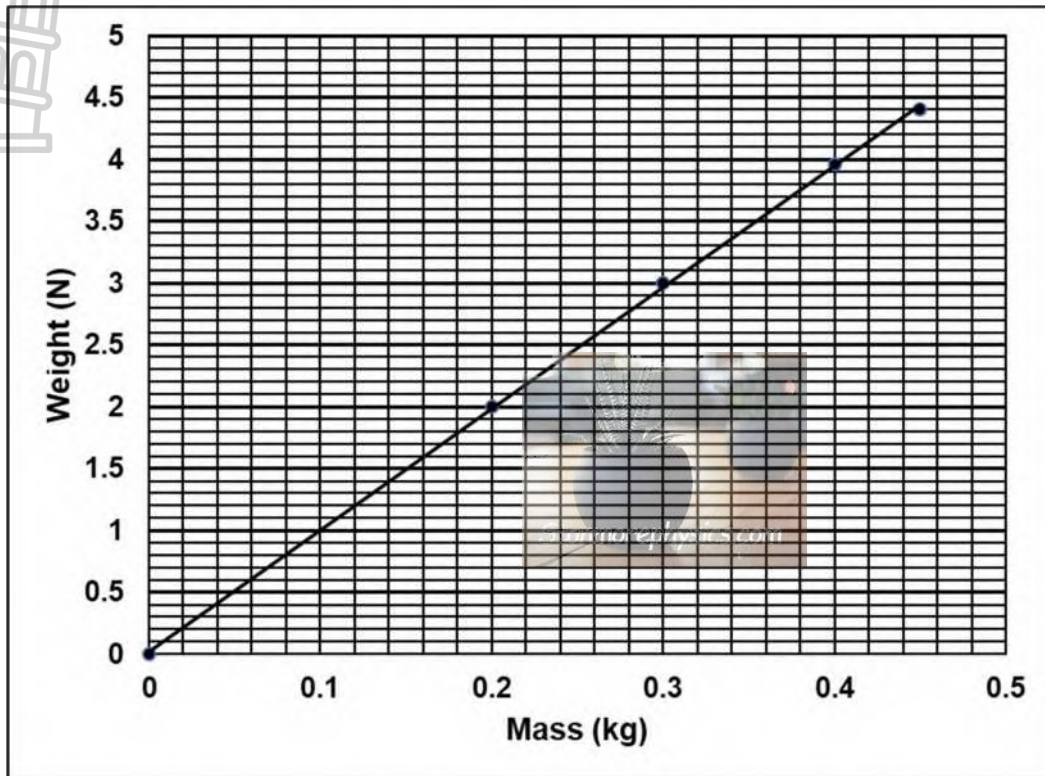

- (a) What is the weight of the object when its mass is 0,1 kg? (1)
- (b) What is the mass of the object when its weight is 4,4 N? (1)
- (c) What is the relationship between mass and weight? (2)
- (d) Mention one variable that must be controlled to make this a fair test. (1)

4.3 A learner was instructed to sketch the magnetic field lines between the opposite poles of two bar magnets facing each other.



The learner produced the following INCORRECT drawing.

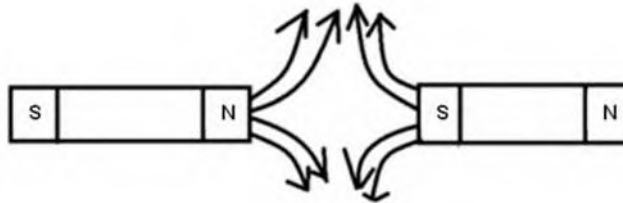

Copy the two bar magnets in your answer book. Redraw the field lines to illustrate the correct magnetic field existing between the two bar magnets. (2)

4.4 A wooden box is placed on a ROUGH (coarse) inclined surface. The wooden box remains in one position and does not slide down the inclined surface.

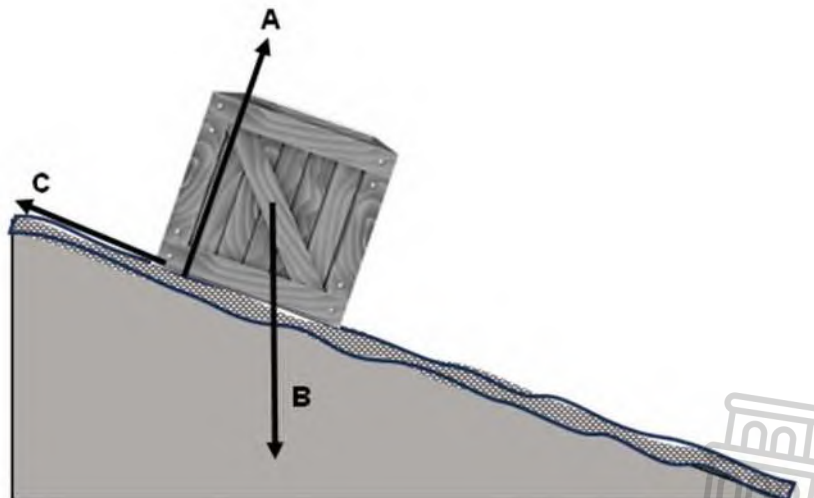

4.4.1 NAME the force preventing the box from sliding down the incline. (1)

4.4.2 In the diagram above, identify the force that is preventing the box from sliding down the surface. Choose between A, B, or C. (1) [17]

QUESTION 5

5.1 An LED is connected to a cell, made from one lemon, a zinc nail and a copper coin.

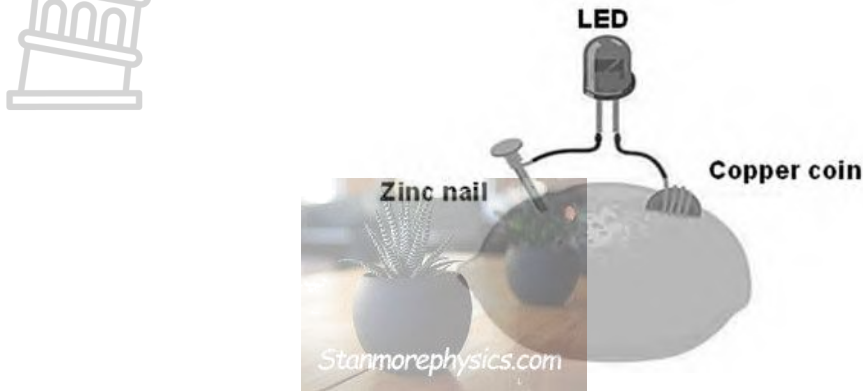

5.1.1 What is the function of an electric cell? (1)

5.1.2 The LED does NOT light up. Suggest a practical solution to resolve this problem. (2)

5.2 When a resistor in an electric circuit heats up, the resistance of the resistor increases.

5.2.1 Name AND discuss two OTHER factors that can also affect the resistance of a resistor. (4)

5.2.2 The following circuits are set up.

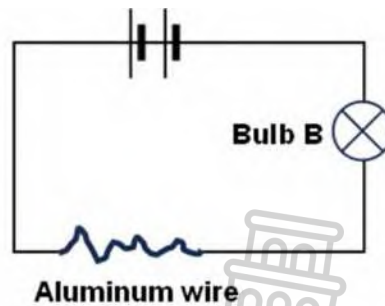
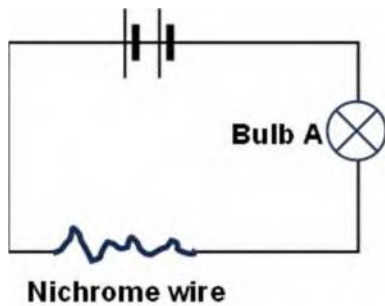

Bulb A glows much dimmer than bulb B.

(a) Which resistor, nichrome or aluminium, has the highest resistance? (1)

(b) What will happen to the brightness of bulb A if the nichrome wire is disconnected from the circuit, cut in half, and one of the halves is then reconnected to the circuit? (1)

(c) Name one example of the use of resistors in every day life. (1)

[10]

QUESTION 6

6.1 Three circuits are connected as shown below. All the bulbs, cells and ammeters are identical.

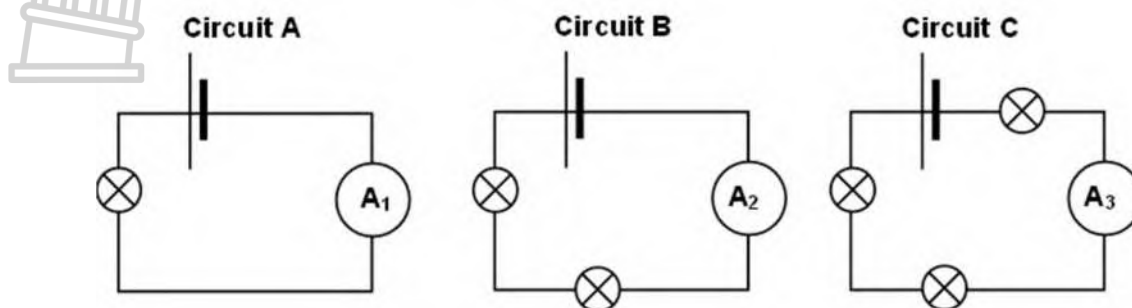

6.1.1 How does circuits A, B and C differ from each other? (1)

6.1.2 Explain why the reading on ammeter A₃ will be less than the ammeter reading on A₁. (2)

6.2 Study the circuit diagram below. The readings on voltmeters V₁, V₃, and V₄, are 2 V, 7 V, and 12 V, respectively.

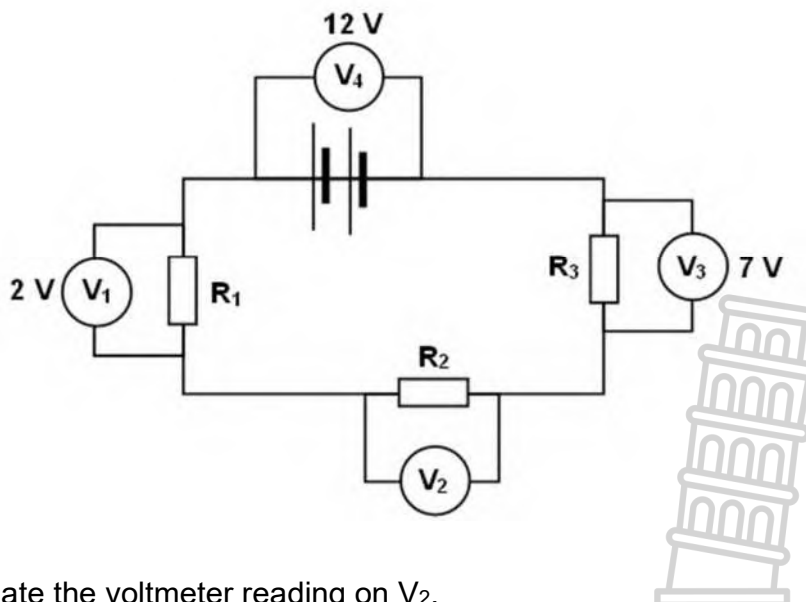

6.2.1 Calculate the voltmeter reading on V₂. (2)

6.2.2 Which resistor, R₁, R₂ or R₃ has the lowest resistance? (1) [6]

QUESTION 7

Circuit 1 and circuit 2 are connected as shown below. All the bulbs and cells are identical.

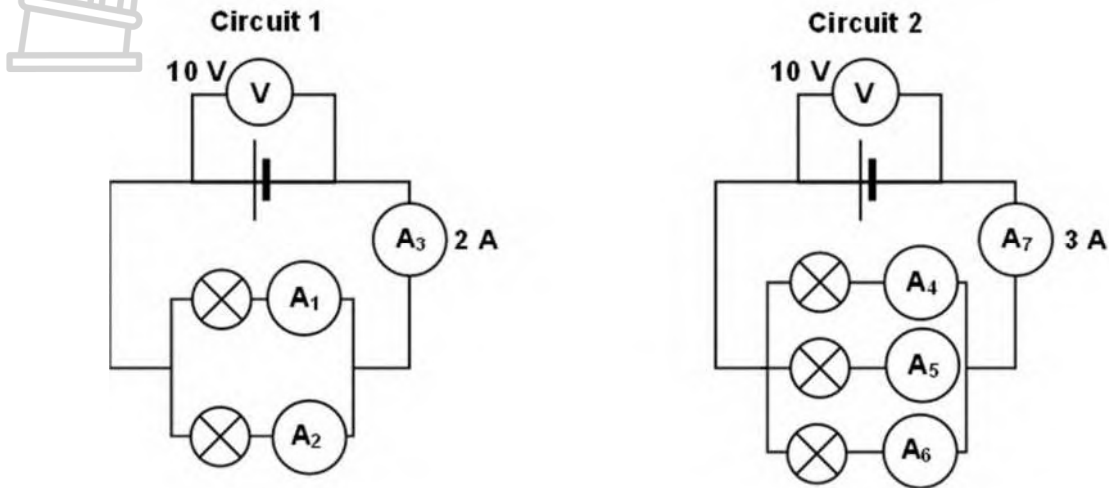

- 7.1 Explain why the voltmeter readings across all the bulbs will be the same. (1)
- 7.2 Explain why the total current in circuit 1 is less than the total current in circuit 2. (2)
- 7.3 Determine the readings on A_1 and A_2 . (1)
- 7.4 Determine the readings on A_4 , A_5 and A_6 . (1)
- 7.5 How does the brightness of the bulbs in circuit 1 compare to that of the bulbs in circuit 2? (1)

[6]



QUESTION 8

The diagram below shows an old-fashioned fridge and a modern energy-saving fridge.



- 8.1 What is the power rating of the old-fashioned fridge? (1)
- 8.2 Convert 380 W to kW. (1)
- 8.3 Electricity is bought and sold in units of electrical energy. Explain what one unit of electrical energy is. (1)

Use the following formula where necessary:

Cost = Power rating of the appliance x Time used x Unit price of electricity

- 8.4 Calculate the cost to use the 800 W old-fashioned fridge for 10 hours if the unit price of electricity is R 3,00. (2)
- 8.5 Calculate the cost to use the modern 380 W fridge for 10 hours if the unit price of electricity is R 3,00. (2)
- 8.6 Mention two advantages of using energy-saving devices. (2)

[9]

QUESTION 9

The diagram below shows how electricity can be generated.

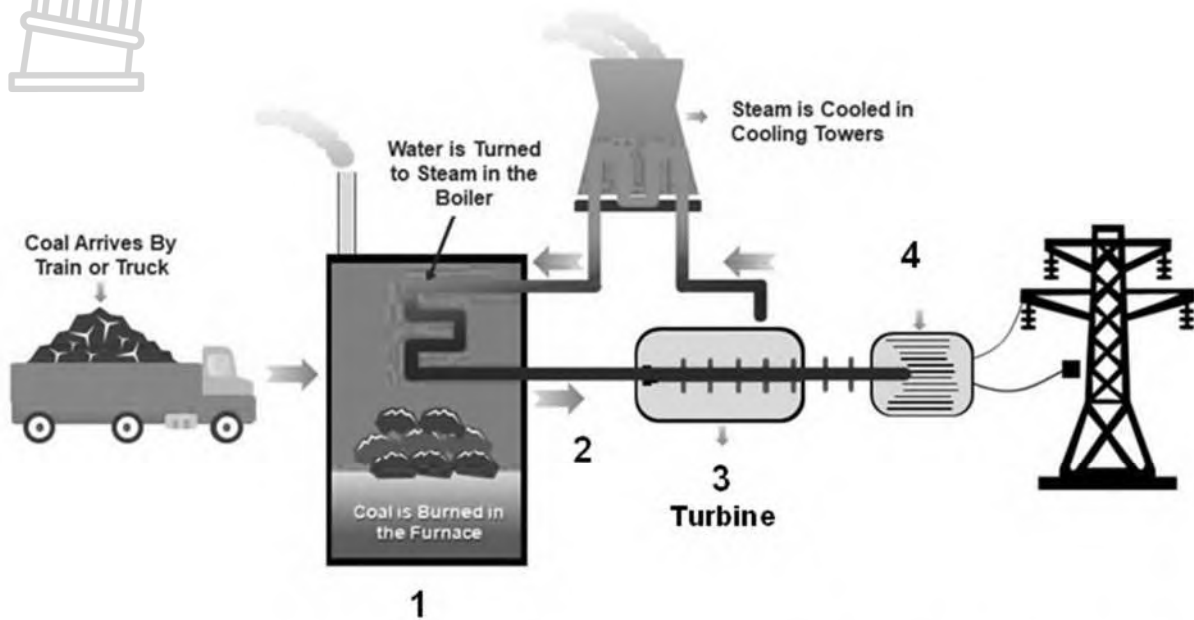

<https://www.slideteam.net/coal-power-plan-diagram-showing-power-station.html>

- 9.1 Provide a suitable heading for the diagram. (1)
- 9.2 What fuel is used to boil the water? (1)
- 9.3 What is used to make the turbine rotate (turn)? (1)
- 9.4 Label part 4 in the diagram. (1)
- 9.5 Give a reason why this method of generating electricity is NOT sustainable. (1)
- 9.6 Suggest three alternative methods that can be used to generate electricity which is sustainable with very little impact on the environment. (3)

[8]

QUESTION 10

Shown below is a tree growing in the soil. Answer the questions that follow.



- 10.1 Name the Earth's sphere composed of soil, rock and various minerals. (1)
 - 10.2 What role does the Earth's solid surface play in supporting the tree? (1)
 - 10.3 Water in the ground is really important for trees to grow. Of which sphere is groundwater a part of? (1)
 - 10.4 Explain how the air (part of the atmosphere) around the tree is involved in its life processes. (2)
- [5]**

QUESTION 11

The diagram below represents the structure of the Earth.

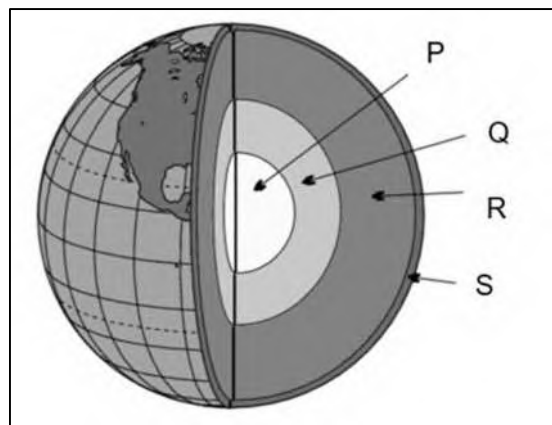

- 11.1 Provide labels for the layers marked P, R and S (3)

11.2 Consider the picture of a volcano.

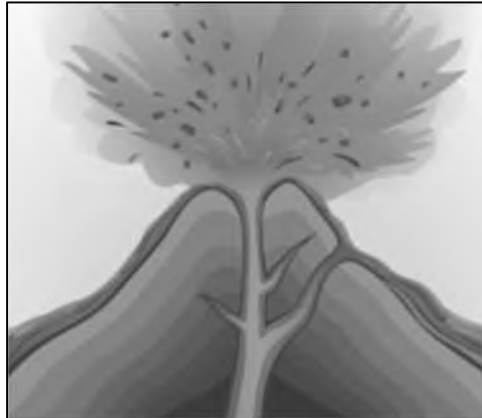

- 11.2.1 What is molten rock called when found on the inside of a volcano? (1)
- 11.2.2 What type of rock is formed when molten rock from a volcano cools down and solidifies (crystallizes) on the Earth's surface? (1)
- 11.2.3 Explain why fossils are not found in igneous rocks. (1)
- 11.2.4 Explain how metamorphic rocks are formed. (2)
- 11.2.5 Which one of the rock types mentioned below is an example of a sedimentary rock?

Marble	Basalt	Coal
--------	--------	------

(1)
[9]



QUESTION 12

The graph below indicates the average temperature of the earth's atmosphere at different heights above the surface of the Earth. Letters A, B, C and D represent the different atmospheric layers.

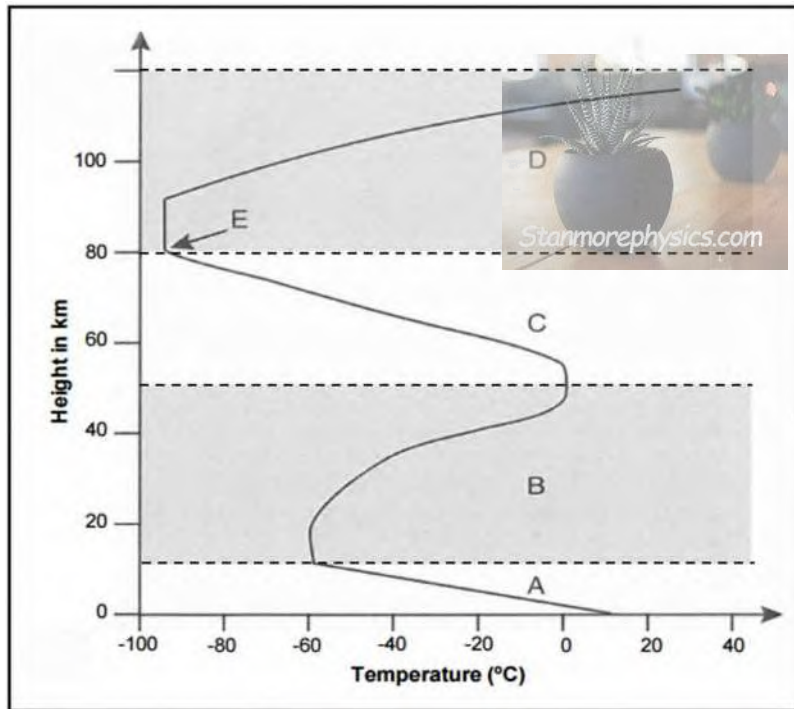

- 12.1 Provide the names of the atmospheric layers labelled A, B, C and D shown in the graph. Write down the letters A to D, followed by the name of the correct atmospheric layer. (4)
- 12.2 Write down the temperature of atmospheric layer B at a height of 20 km above the surface of the earth. (1)
- 12.3 Write down the relationship between the height above the Earth's surface and the temperature in layer B when moving upward from 20 km to 50 km above the Earth's surface. (2)
- 12.4 Write down the name of the thin layer of gas found in B which is responsible for protecting living organisms on the surface of the Earth against the harmful radiation from the Sun. (1)
- 12.5 Give TWO negative consequences of the phenomenon known as global warming. (2)

[10]

TOTAL SECTION B: 80
GRAND TOTAL: 100



education

Department of
Education
FREE STATE PROVINCE

GRADE 9

NATURAL SCIENCES

NOVEMBER 2023

Stanmorephysics.com

MEMORANDUM

MARKS: 100

This memorandum consists of 8 pages



SECTION A

QUESTION 1

- 1.1 A ✓ (1)
- 1.2 C ✓ (1)
- 1.3 D ✓ (1)
- 1.4 B ✓ (1)
- 1.5 D ✓ (1)
- 1.6 B ✓ (1)
- 1.7 C ✓ (1)
- 1.8 C ✓ (1)
- 1.9 D ✓ (1)
- 1.10 B ✓ (1)

[10]

QUESTION 2

- 2.1 (Electrical) power ✓ (1)
- 2.2 Koeberg ✓ (1)
- 2.3 Hydroelectricity ✓ (1)
- 2.4 Transformer ✓ (1)
- 2.5 Earth ✓ (wire) (1)

[5]

QUESTION 3

- 3.1 B ✓ (1)
- 3.2 E ✓ (1)
- 3.3 G ✓ (1)
- 3.4 H ✓ (1)
- 3.5 I ✓ (1)

[5]

TOTAL SECTION A: 20

SECTION B

QUESTION 4

4.1.1 The objects are not in contact with each other, and the forces are exerted (work) over a distance. ✓ (1)

4.1.2 Iron, cobalt, nickel, a ferromagnetic substance ✓ (ANY ONE) (1)

4.1.3 (a) Negative ✓ (1)

(b) Positive **OR** Neutral ✓ (1)

4.2.1 Mass ✓ (of the objects)
Distance ✓ (between the centers of the two objects) (2)

4.2.2 Mass is the amount of matter an object consists of. ✓
Weight is the gravitational force the earth exerts on an object. ✓ (2)

4.2.3 (a) 1 N ✓ (1)

(b) 0,45 kg ✓ (1)

(c) As mass increases, weight also increases.
OR
Weight is directly proportional to mass.

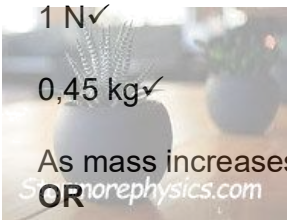

Marking criteria	Marks
Both variables are mentioned: mass and weight	1
The relationship between the variables is indicated.	1

(d) The distance from the (center) of the earth. ✓ (1)

4.3

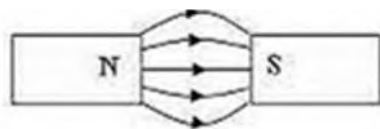

Marking criteria:

- ✓ Shape of the magnetic field.
- ✓ Direction indicated from N to S.

(2)

4.4.1 Friction / Frictional force ✓ (1)

4.4.2 C ✓ (1)

[17]

QUESTION 5

5.1.1 To provide energy for the current to flow. ✓

OR

A cell is a source of energy. ✓

(1)

5.1.2 Connect more (lemon) cells ✓ in series. ✓

(2)

5.2.1 **Length** ✓ of the resistor:

The longer a resistor, the higher the resistance. ✓

OR

The shorter a resistor, the lower the resistance. ✓

Thickness ✓ of the resistor:

The thinner the resistor, the higher the resistance. ✓

OR

The thicker the resistor, the lower the resistance. ✓

Type of resistor: ✓

Some metals have a lower/higher resistance than others. ✓

Marking criteria:

✓Thickness; ✓Discussion

✓Length; ✓Discussion

✓Type; ✓Discussion

(ANY TWO) (4)

5.2.2 (a) Nichrome ✓

(1)

(b) The bulb will glow brighter. ✓

(1)

(c) Elements in kettles, geysers, heaters, toasters, stove plates ✓

Bulb filaments ✓

Rheostats (variable resistors) ✓

Motors ✓

Light sensitive diodes, light emitting diodes/LEDs ✓

(ANY ONE) (1)

[10]

QUESTION 6

6.1.1 The number of bulbs in series increases from circuit A to B to C. ✓ (1)

6.1.2 More bulbs/resistors in series ✓ in circuit C.
Higher overall resistance. ✓
Lower current / Smaller ammeter reading. (Given; no mark awarded.) (2)

6.2.1 $V_2 = 12\text{ V} - (2\text{ V} + 7\text{ V})$ ✓
 $= 3\text{ V}$ ✓ (2)

6.2.2 R_1 ✓ (1)
[6]

QUESTION 7

7.1 The bulbs are connected in parallel ✓ (to batteries with the same potential difference).
OR
Bulbs connected in parallel are NOT potential dividers, ✓ but current dividers. (1)

7.2 Circuit 1 has less bulbs connected in parallel. ✓
Overall resistance is higher ✓ than in circuit 2.
The overall current in circuit 1 is therefore less than the current in circuit 2.
OR
Circuit 2 has more bulbs connected in parallel. ✓
Overall resistance is lower ✓ than in circuit 2.
The overall current in circuit 2 is therefore more than the current in circuit 1. (2)

7.3 $A_1 = A_2 = 2\text{ A} \div 2 = 1\text{ A}$ ✓ (1)

7.4 $A_4 = A_5 = A_6 = 3\text{ A} \div 3 = 1\text{ A}$ ✓ (1)

7.5 All bulbs will have the same brightness. ✓ (1)
[6]



QUESTION 8

- 8.1 800 W ✓ (1)
- 8.2 $380 \text{ W} \div 1000 = 0,38 \text{ kW}$ ✓ (1)
- 8.3 1 kW used for 1 hour ✓ **OR** 1 kWh ✓ (1)
- 8.4 Cost = Power rating of the appliance x Time used x Unit price of electricity
= $0,8 \times 10 \times 3$ ✓
= R 24,00 ✓ (Accept: R 24; answer with unit) (2)
- 8.5 Cost = Power rating of the appliance x Time used x Unit price of electricity
= $0,38 \times 10 \times 3$ ✓
= R 11,40 ✓ (Rounded to 2 decimals) (2)
- 8.6 It saves money / is cheaper / costs less to use energy-saving devices. ✓
Less electricity must be generated, therefore less fossil fuel is used. ✓
Smaller negative impact on the environment / less greenhouse gases are emitted /
less pollution. ✓
Reduces the demand for electricity and can lead to less loadshedding. ✓

(ANY TWO) (2)
[9]

QUESTION 9

- 9.1 Power station / Coal-fired power station ✓ (1)
- 9.2 Coal ✓ (1)
- 9.3 Steam ✓ (1)
- 9.4 Generator ✓ (1)
- 9.5 Coal is a fossil fuel and cannot be replaced / replenished. ✓ (1)
- 9.6 Solar energy ✓
Wind energy ✓
Hydro-energy ✓
Wave energy ✓
Biomass ✓
(Accept: Nuclear energy ✓)



(ANY THREE) (3)
[8]

QUESTION 10

- 10.1 Lithosphere✓ (1)
- 10.2 The roots of the tree are anchored by the soil and keep the tree upright.✓ (1)
- 10.3 Hydrosphere✓ (1)
- 10.4 The leaves of the tree absorb carbon dioxide from the atmosphere for photosynthesis✓ and releases oxygen which supports the respiration of other organisms.✓ (2)
- [5]**



QUESTION 11

- 11.1 P – inner core✓
R - mantle✓
S - crust✓ (3)
- 11.2.1 Magma✓ (1)
- 11.2.2 Igneous rock✓ (1)
- 11.2.3 Fossils are not found in igneous rock because plant and animal remain trapped in lava/igneous rock will be burnt off (incinerated) due to the extreme heat. ✓ (1)
- 11.2.4 When igneous / sedimentary rocks are subjected to high pressure✓ and high temperatures, ✓ they change into metamorphic rock. (2)
- 11.2.5 Coal✓ (1)
- [9]**



QUESTION 12

- 12.1 A - Troposphere✓
B - Stratosphere✓
C - Mesosphere✓
D - Thermosphere✓ (4)

12.2 -60°C✓ (1)

12.3 As the height increases, temperature also increases.

OR

Temperature increases with the increase in height.

Marking criteria	Marks
Both variables are mentioned: height and temperature	1
The relationship between the variables is indicated.	1

(2)

12.4 Ozone✓ (1)

12.5 Global warming can lead to:

- climate change / severe storms / severe droughts✓
- rising sea levels / warming oceans✓
- food shortages✓
- mass extinction✓
- health risks✓
- poverty / displacements✓

(ANY TWO) (2)
[10]

TOTAL SECTION B: 80
GRAND TOTAL: 100

