



education
MPUMALANGA PROVINCE
REPUBLIC OF SOUTH AFRICA

**NATIONAL
SENIOR CERTIFICATE**

GRADE 12

MATHEMATICS P1

SEPTEMBER 2024

Stanmorephysics.com

MARKS: 150

TIME: 3 hours

This question paper consists of 9 pages, including an information sheet.

INSTRUCTIONS AND INFORMATION

Read the following instructions carefully before answering the questions.

1. The question paper consists of 9 questions.
2. Answer ALL the questions.
3. Clearly show ALL calculations, diagrams, graphs, etc. which you have used in determining the answers.
4. Answers only will NOT necessarily be awarded full marks.
5. You may use an approved scientific calculator (non-programmable and non-graphical) unless stated otherwise.
6. If necessary, round off answers to TWO decimal places, unless stated otherwise.
7. Diagrams are NOT necessarily drawn to scale.
8. Write neatly and legibly.



QUESTION 1

1.1 Solve for x :

1.1.1 $(2-x)(x+3) = 0$ (2)

1.1.2 $3x^2 - 4x = 5$ (4)

1.1.3 $\sqrt{5-x} - x = 1$ (5)

1.1.4 $x(x-5) < 0$ (2)

1.2 Solve for x and y simultaneously:

$$-2y + x = -1$$

$$x^2 - 7 - y^2 = -y$$

(6)

1.3 Prove that the roots of the following equation are non-real for all real values of a and b , $a \neq 0$ and $b \neq 0$.

$$a^2x^2 + abx + b^2 = 0$$

(3)

[22]

QUESTION 2

2.1 Consider the following quadratic sequence: $6; x; 26; 45; y; \dots$
Determine the values of x and y .

(6)

2.2 Given the following series: $220 + 213 + 206 + \dots - 11$

2.2.1 Calculate the sum of the series.

(5)

2.2.2 Write the series in sigma-notation.

(3)

2.3 A ball is dropped from a height of 15 m. It bounces back and loses 10% of its previous height on each bounce. Show that the total distance the ball will bounce cannot exceed 290m.

(4)

2.4 Given: $25\left(\frac{1-t}{3}\right) + 5\left(\frac{1-t}{3}\right)^2 + \left(\frac{1-t}{3}\right)^3 + \dots$

2.4.1 For which value(s) of t will the series converge?

(3)

2.4.2 If $t = 15$, calculate the sum to infinity of the series if it exists.

(4)

2.5 The sum of the first n terms of a sequence is $S_n = 2^{n-5} + 3$.

Determine the 70th term. Leave your answer in the form $a \cdot b^p$ where a , b and p are all integers.

(4)

[29]

QUESTION 3

3.1 The sketch below shows the graph of $f(x) = \frac{a}{x+p} + q$ and $g(x) = b^x + c$. The x -intercept is at $(-6; 0)$, and the y -intercepts of f and g is at $(0; -3)$. The point $(2; 5)$ lies on the graph of g .

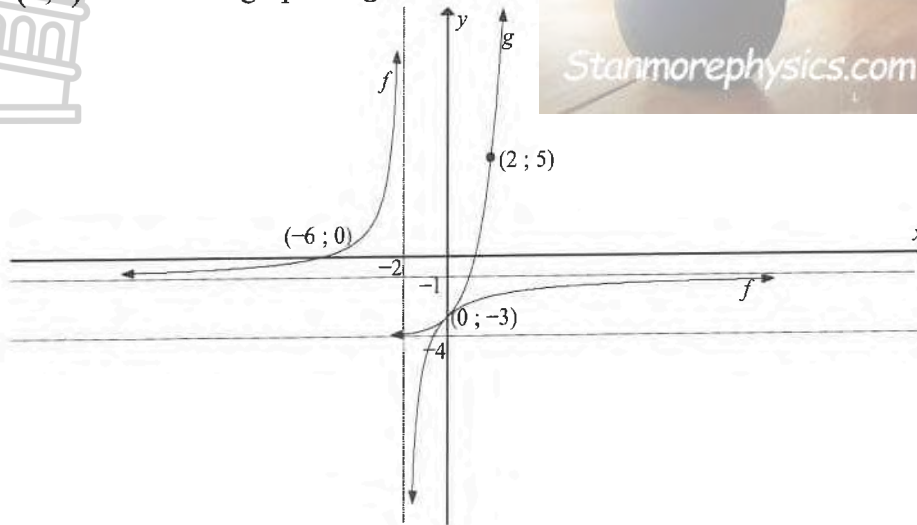
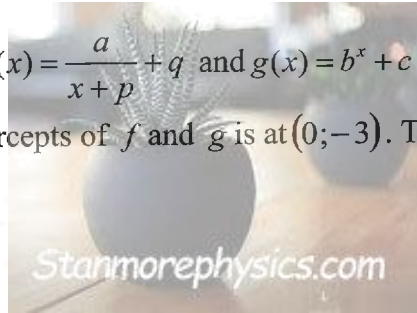
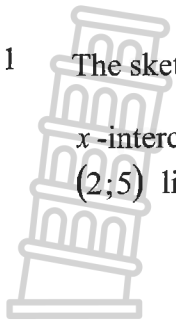

- 3.1 For which value(s) of x is $f(x) = g(x)$. (1)
- 3.2 Write down the equation of the asymptotes of f . (2)
- 3.3 Hence determine the equation of g . (4)
- 3.4 Write down the range of f . (2)
- 3.5 Determine the equation of k if $k(x)$ is the reflection of g along the x -axis followed by a translation 4 units down. (2)
- 3.6 Determine the equation of $p(x)$, the axis of symmetry of f , if $p'(x) < 0$. (3)
- 3.7 For which values of x is $x \cdot g'(x) \geq 0$? (2)

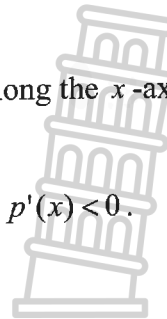

[16]

QUESTION 4

The graphs of $f(x) = -x^2 + x + 6$ and $g(x) = 3x + 10$ are drawn below. C and D are the x -intercepts of f . A is a point on f and B is a point on g such that AB is parallel to the y -axis.

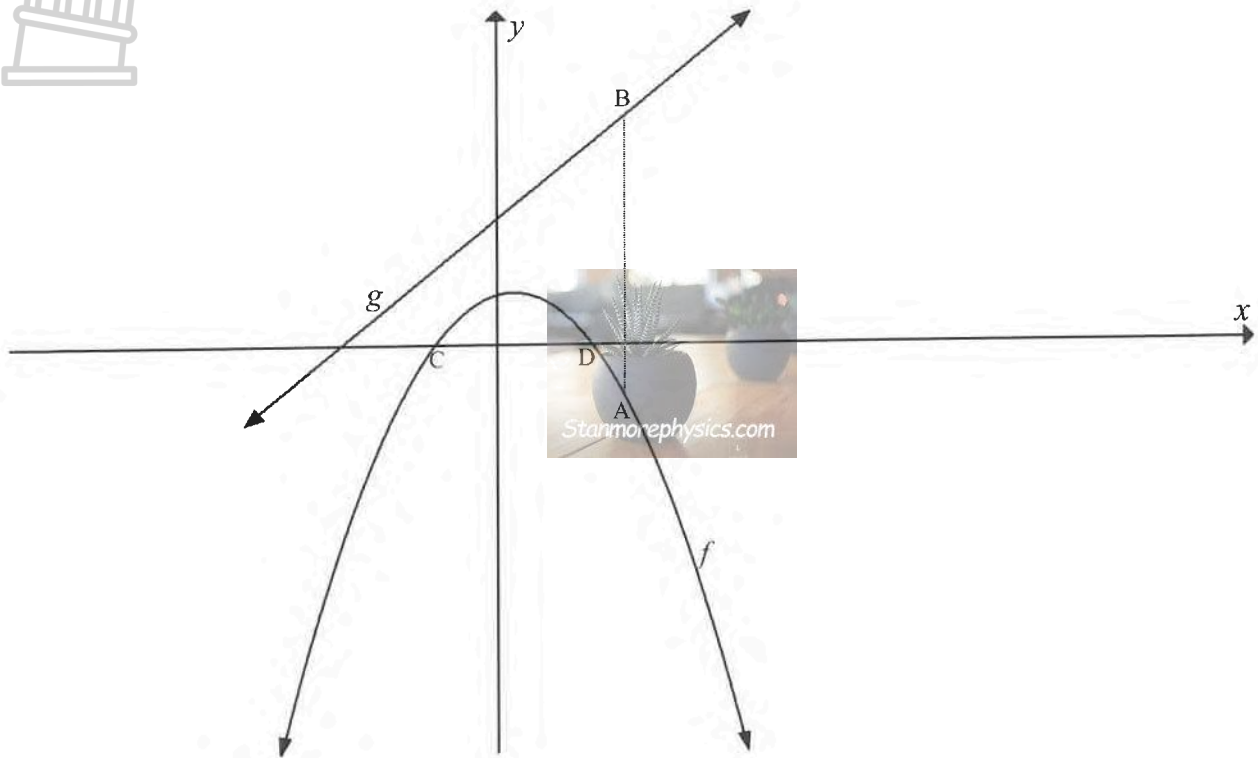

- 4.1 Calculate the coordinates of the turning point of f . (3)
- 4.2 Calculate the distance of CD. (2)
- 4.3 Calculate the vertical distance of AB in terms of x . (2)
- 4.4 Calculate the smallest distance of AB between f and g . (4)
- 4.5 Write the values of x for which $f(x) \cdot g(x) > 0$ (3)
- 4.6 If $f(x) + 2 = k$ has two distinct roots, determine the value(s) of k . (3)

[17]

QUESTION 5

- 5.1 How long will it take an item to depreciate to one quarter of its initial value if it does so at a rate of 11,84% p.a. on the reducing balance-method? (3)
- 5.2 Daniel wishes to purchase a bike for R72 000. He takes out a loan at a rate of 9,8% per annum compounded monthly. Calculate:
- 5.2.1 the monthly instalment if the loan is to be paid back over 5 years. He makes his first payment one month after the loan is granted. (4)
- 5.2.2 the outstanding balance after 3,5 years. (3)
- 5.2.3 the amount that would be saved by settling the loan after 3,5 years instead of 5 years. (3)
- 5.3 After making the 6th-payment, Kgosi has an outstanding balance of R793749,25 from a loan of R800 000. He then missed the 7th, 8th and 9th payment due to financial difficulties. He resumed payments at the end of 10th month onwards. Calculate his increased monthly payments in order to settle the loan within the stipulated 20 years, if interest was 10,25% per annum, compounded monthly. (5)

Stanmorephysics.com

[18]

QUESTION 6

- 6.1 Given $f(x) = -\frac{2}{x}$
Determine $f'(x)$ from first principles. (5)
- 6.2 Determine:
- 6.2.1 $\frac{dy}{dx}$ if $xy - 2y = x^2 - 4$ (3)
- 6.2.2 $D_x \left[\sqrt[5]{\frac{32}{x^3}} \right]$ (3)

[11]



QUESTION 7

Given: $f(x) = 1 - 125x^3$

7.1 Determine the coordinates of the:

7.1.1 stationary point(s) (2)

7.1.2 point of inflection if it exists. (2)

7.2 Draw the graph of f . Show all the intercepts with the axes as well as stationary points if any. (3)

7.3 Give the values of x for which the graph is concave up. (1)

7.4 Determine the equation of the tangent to the graph at $x = \frac{1}{10}$. (4)

[12]

QUESTION 8

The radius of the base of a cylindrical cold drink can is x cm, and its volume 440 cm^3 .

$$A = \pi r^2, C = 2\pi r, V = \pi r^2 h$$

8.1 Determine the height of the can in terms of x . (2)

8.2 Show that the area of the material needed to manufacture the can is $2\pi x^2 + \frac{880}{x}$. (2)

8.3 Determine the value of x (correct to two decimals) for which the least amount of material is needed to manufacture such a can. (4)

[8]



QUESTION 9

9.1 Events A and B are mutually exclusive. It is given that:

- $P(B) = 2P(A)$
- $P(A \text{ or } B) = 0,57$

Calculate $P(B)$.

(4)

9.2 There are 5 loaves of brown bread (B) and 7 loaves of white (W) bread on a shelf at the local supermarket. Two clients, one followed by the other, each randomly select a loaf of bread from their shelf and put it their basket.

9.2.1 Determine the probability that the first client takes a loaf of white bread.

(1)

9.2.2 Assume that the owner of the shop does not replace any of the loaves of bread on the shelf after a client has taken a loaf of bread.

Determine the probability that both clients take a loaf of brown bread.

(3)

9.2.3 If the first client takes a loaf of white bread, the owner of the shop places a loaf of brown bread with the other loaves on the shelf. If the first client takes a loaf of brown bread, the owner of the shop places a loaf of white bread with the other loaves on the shelf.

Determine the probability that a loaf of white bread and a loaf of brown bread is sold to the two clients.

(4)

9.3 Every morning a father has to drop his children off at school on his way to work and pick them up again on his way home from work. There are 3 different roads from home to school and 5 different roads from school to work.

In how many ways can the father:

9.3.1 travel from his home to work?

(1)

9.3.2 travel from his home to work and back to his home?

(2)

9.3.3 travel from his home to work and back home if he does not use the same road twice?

(2)

[17]

TOTAL MARKS = 150

INFORMATION SHEET

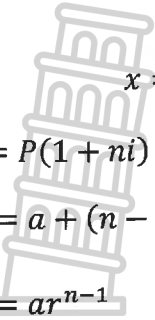

$$x = \frac{-b \pm \sqrt{b^2 - 4ac}}{2a}$$

$$A = P(1 + ni)$$

$$A = P(1 - ni)$$

$$A = P(1 - i)^n$$

$$A = P(1 + i)^n$$

$$T_n = a + (n - 1)d$$

$$S_n = \frac{n}{2}[2a + (n - 1)d]$$

$$T_n = ar^{n-1}$$

$$S_n = \frac{a(r^n - 1)}{r - 1}; r \neq 1$$

$$S_\infty = \frac{a}{1 - r}; -1 < r < 1$$

$$F = \frac{x[(1 + i)^n - 1]}{i}$$

$$P = \frac{x[1 - (1 + i)^{-n}]}{i}$$

$$f'(x) = \lim_{h \rightarrow 0} \frac{f(x + h) - f(x)}{h}$$

$$d = \sqrt{(x_2 - x_1)^2 + (y_2 - y_1)^2}$$

$$M\left(\frac{x_1 + x_2}{2}; \frac{y_1 + y_2}{2}\right)$$

$$y = mx + c \quad y - y_1 = m(x - x_1)$$

$$m = \frac{y_2 - y_1}{x_2 - x_1} \quad m = \tan \theta$$

$$(x - a)^2 + (y - b)^2 = r^2$$

$$\text{In } \triangle ABC: \frac{a}{\sin A} = \frac{b}{\sin B} = \frac{c}{\sin C}$$

$$a^2 = b^2 + c^2 - 2bc \cdot \cos A$$

$$\text{area } \triangle ABC = \frac{1}{2}ab \cdot \sin C$$

$$\sin(\alpha + \beta) = \sin \alpha \cdot \cos \beta + \cos \alpha \cdot \sin \beta$$

$$\sin(\alpha - \beta) = \sin \alpha \cdot \cos \beta - \cos \alpha \cdot \sin \beta$$

$$\cos(\alpha + \beta) = \cos \alpha \cdot \cos \beta - \sin \alpha \sin \beta$$

$$\cos(\alpha - \beta) = \cos \alpha \cdot \cos \beta + \sin \alpha \sin \beta$$

$$\cos 2\alpha = \cos^2 \alpha - \sin^2 \alpha$$

$$\sin 2\alpha = 2 \sin \alpha \cos \alpha$$

$$= 1 - 2\sin^2 \alpha$$

$$= 2\cos^2 \alpha - 1$$

$$\bar{x} = \frac{\sum fx}{n}$$

$$\sigma^2 = \frac{\sum_{i=1}^n (x_i - \bar{x})^2}{n}$$



$$P(A) = \frac{n(A)}{n(S)}$$

$$P(A \text{ of } B) = P(A) + P(B) - P(A \text{ en } B)$$

$$\hat{y} = a + bx$$

$$b = \frac{\sum(x - \bar{x})(y - \bar{y})}{\sum(x - \bar{x})^2}$$



education

MPUMALANGA PROVINCE
REPUBLIC OF SOUTH AFRICA

**NATIONAL
SENIOR CERTIFICATE**

GRADE 12

MATHEMATICS P1/WISKUNDE V1

SEPTEMBER 2024

MARKING GUIDELINES / NASIENRIGLYNE

MARKS / PUNTE: 150

The marking guidelines consist of 12 pages.

Die nasienriglyne bestaan uit 12 bladsye.

TAKE NOTE:

- If a candidate answered a question TWICE, mark only the FIRST attempt.
- If a candidate crossed out an answer and did not redo it, mark the crossed-out answer.
- Consistent accuracy applies to ALL aspects of the marking guidelines.
- Assuming values/answers in order to solve a problem is unacceptable.

LET WEL:

- As 'n kandidaat 'n vraag TWEE keer beantwoord het, sien slegs die EERSTE poging na.
- As 'n kandidaat 'n antwoord deurgehaal en nie oorgedoen het nie, sien die deurgehaalde antwoord na.
- Volgehoue akkuraatheid is op ALLE aspekte van die nasienriglyn van toepassing.
- Dit is onaanvaarbaar om waardes/antwoorde te veronderstel om 'n probleem op te los.

QUESTION 1

1.1.1	$x = 2$ or $x = -3$	✓ $x = 2$ ✓ $x = -3$	(2)
1.1.2	$3x^2 - 4x - 5 = 0$ $x = \frac{-(-4) \pm \sqrt{(-4)^2 - 4(3)(-5)}}{2(3)}$ $x = 2,12$ or $x = -0,79$	✓ standard form ✓ substitution ✓✓ x -values	(4)
1.1.3	$\sqrt{5-x} = 1+x$ $5-x = (1+x)^2$ $5-x = 1+2x+x^2$ $x^2+3x-4=0$ $(x+4)(x-1)=0$ $x \neq -4$ or $x = 1$	✓ isolating surd ✓ squaring both sides ✓ standard form ✓ factoring ✓ $x \neq -4$ or $x = 1$	(5)
1.1.4	$0 < x < 5$	✓✓ answer	(2)

1.2	$x = -1 + 2y$ $(-1 + 2y)^2 - 7 - y^2 = -y$ $3y^2 - 3y - 6 = 0$ $y^2 - y - 2 = 0$ $(y - 2)(y + 1) = 0$ $y = 2 \text{ or } y = -1$ $x = -1 + 2(2) \text{ or } x = -1 + 2(-1)$ $= 3 \qquad = -3$ OR $y = \frac{1+x}{2}$ $x^2 - 7 - \left(\frac{1+x}{2}\right)^2 = -\left(\frac{1+x}{2}\right)$ $x^2 - 7 - \frac{1+2x+x^2}{4} = -\left(\frac{1+x}{2}\right)$ $4x^2 - 28 - x^2 - 2x - 1 = -2 - 2x$ $x^2 - 9 = 0$ $(x-3)(x+3) = 0$ $x = 3 \text{ or } x = -3$ $y = \frac{1+3}{2} \text{ or } y = \frac{1-3}{2}$ $= 2 \qquad = -1$	✓ $x = -1 + 2y$ ✓ substitution of x ✓ standard form ✓ factors ✓ both y -values ✓ both x -values (6) ✓ $y = \frac{1+x}{2}$ ✓ substitution ✓ standard form ✓ factors ✓ both x -values ✓ both y -values (6)
1.3	$\Delta = (ab)^2 - 4(a^2)(b^2)$ $= -3a^2b^2$ $-3a^2b^2 < 0$ <p>∴ roots are non-real for all real values of a and $b \neq 0$</p>	✓ substitution ✓ $-3a^2b^2$ ✓ $-3a^2b^2 < 0$ + conclusion (3) [22]

QUESTION 2

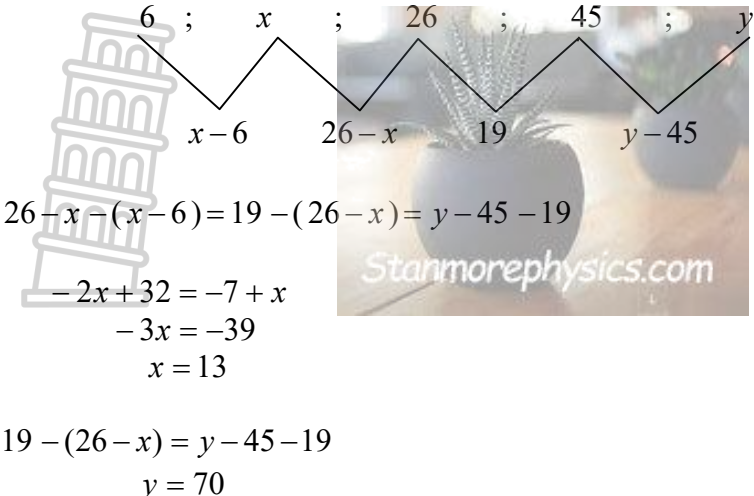
<p>2.1</p>	 <p> $26 - x - (x - 6) = 19 - (26 - x) = y - 45 - 19$ $-2x + 32 = -7 + x$ $-3x = -39$ $x = 13$ </p> <p> $19 - (26 - x) = y - 45 - 19$ $y = 70$ </p>	<ul style="list-style-type: none"> ✓ 1st differences ✓ 2nd differences ✓ equate 2nd differences ✓ value of x ✓ substitute ✓ value of y (6)
<p>2.2.1</p>	<p> $220 + 213 + 206 + \dots - 11$ $d = -7$ </p> <p> $T_n = 220 + (n - 1)(-7) = -11$ $-7n + 227 = -11$ $-7n = -238$ $n = 34$ </p> <p> $S_{34} = \frac{34}{2} [2(220) + (34 - 1)(-7)]$ OR $S_{34} = \frac{34}{2} [220 + (-7)]$ $= 3\ 553$ </p>	<ul style="list-style-type: none"> ✓ substitution in T_n ✓ equate to -11 ✓ value of n ✓ substitution in S_n ✓ answer (5)
<p>2.2.2</p>	<p> $\sum_{n=1}^{34} (-7n + 227)$ </p>	<ul style="list-style-type: none"> ✓ $\sum_{n=1}^{34}$ ✓ ✓ $(-7n + 227)$ (3)
<p>2.3</p>	<p> $S_n = 15 + 2\left(\frac{13,5}{1 - 0,9}\right)$ $= 285$ < 290 </p> <p style="text-align: center;">OR</p> <p> $S_n = \frac{15}{1 - 0,9} + \frac{13,5}{1 - 0,9}$ $= 285$ < 290 </p>	<ul style="list-style-type: none"> ✓ 15 ✓ 2 ✓ $\frac{13,5}{1 - 0,9}$ ✓ 285 (4) <p style="text-align: center;">OR</p> <ul style="list-style-type: none"> ✓ $\frac{15}{1 - 0,9}$ ✓ $\frac{13,5}{1 - 0,9}$ ✓ sum ✓ 285 (4)
<p>2.4.1</p>	<p> $r = \frac{1}{5}\left(\frac{1-t}{3}\right)$ and the series converges for $-1 < r < 1$ </p>	<ul style="list-style-type: none"> ✓ r

	$-1 < \frac{1}{5} \left(\frac{1-t}{3} \right) < 1$ $-15 < 1-t < 15$ $-16 < -t < 14$ $-14 < t < 16$	✓ substitution ✓ answer (3)
2.4.2	$r = \frac{1}{5} \left(\frac{1-15}{3} \right) = \frac{-14}{15}$ $\therefore S_n \text{ exists}$ $a = 25 \left(\frac{1-15}{3} \right) = \frac{-350}{3}$ $S_\infty = \frac{-350}{1 - \left(\frac{-14}{15} \right)}$ $= \frac{-1750}{29}$	✓ value of r ✓ value of a ✓ substitution into S_∞ ✓ answer (4)
2.5	$S_{70} = 2^{70-5} + 3 = 2^{65} + 3$ $S_{69} = 2^{69-5} + 3 = 2^{64} + 3$ $\therefore T_{70} = S_{70} - S_{69}$ $= 2 \cdot 2^{64} - 2^{64}$ $= 1 \cdot 2^{64}$	✓ S_{70} ✓ S_{69} ✓ substitution in T_{70} ✓ $1 \cdot 2^{64}$ (4)
		[29]

QUESTION 3

3.1	$x = 0$	✓ answer (1)
3.2	$x = -2$ $y = -1$	✓ ✓ equations (2)
3.3	$g(x) = b^x + c$ $y = b^x - 4$ $5 = b^2 - 4$ $9 = b^2$ $3^2 = b^2$ $b = 3$ $g(x) = 3^x - 4$	✓ substitution of asymptote ✓ substitution of (2 ; 5) ✓ value of b ✓ equation (4)

3.4	$y \in (-\infty; -1) \cup (-1; \infty)$ OR $y < -1$ or $y > -1$ OR $y \in R, y \neq -1$	✓ critical points ✓ notation (2)
3.5	$k(x) = -(3^x - 4) - 4$ $= -3^x + 4 - 4$ $= -3^x$	✓ $-g(x) - 4$ ✓ answer (2)
3.6	$y = -x + c$ $-1 = -(-2) + c$ OR $y = -(x + 2) - 1$ $-3 = c$ OR $= -x - 3$ $\therefore y = -x - 3$	✓ negative gradient ✓ substitution ✓ answer (3)
3.7	$x \in [0; \infty)$ OR $x \geq 0$	✓ ✓ answer (2)
		[16]

QUESTION 4

4.1	$x = -\frac{1}{2(-1)}$ OR $f'(x) = -2x + 1 = 0$ $x = \frac{1}{2}$ OR $x = \frac{1}{2}$ $y = -\left(\frac{1}{2}\right)^2 + \frac{1}{2} + 6$ $= \frac{25}{4}$ $\therefore T.P\left(\frac{-1}{2}; \frac{25}{4}\right)$	✓ $x = \frac{1}{2}$ ✓ y-value ✓ answer (3)
4.2	$-x^2 + x + 6 = 0$ $x^2 - x - 6 = 0$ $(x - 3)(x + 2) = 0$ $x = 3$ or $x = -2$ $\therefore CD = 5$ units	✓ factors ✓ answer (2)
4.3	$AB(x) = 3x + 10 - (-x^2 + x + 6)$ $= x^2 + 2x + 4$	✓ subtracting ✓ answer (2)
4.4	$AB'(x) = 2x + 2 = 0$ $x = -1$ Minimum of AB = $(-1)^2 + 2(-1) + 4$ $= 3$	✓ $AB' = 0$ ✓ x-value ✓ substitution ✓ answer (4)
4.5	$x < -\frac{10}{3}$ or $-2 < x < 3$	✓ $x < -\frac{10}{3}$ ✓ ✓ $-2 < x < 3$ (3)

4.6	$k = f(x) + 2 = -x^2 + x + 8$ TP: $f(x) + 2 = -\left(\frac{1}{2}\right)^2 + \frac{1}{2} + 8$ $y = \frac{33}{4}$ $\therefore k < \frac{33}{4}$	$\checkmark -x^2 + x + 8$ $\checkmark y = \frac{33}{4}$ $\checkmark \therefore k < \frac{33}{4}$ (3)
		[17]

QUESTION 5

5.1	$A = P(1 - i)^n$ $\frac{1}{4}P = P(1 - 0,1184)^n$ $\frac{1}{4} = (1 - 0,1184)^n$ $\log \frac{1}{4} = \log(1 - 0,1184)^n$ $\therefore n = \log_{(1-0,1184)} \frac{1}{4}$ $= 11$	$\checkmark A = \frac{1}{4}P$ \checkmark use of logarithms \checkmark answer (3)
5.2.1	$72000 = \frac{x \left[1 - \left(1 + \frac{0,098}{12} \right)^{-5 \times 12} \right]}{\frac{0,098}{12}}$ $x = \frac{72000 \left(\frac{0,098}{12} \right)}{\left[1 - \left(1 + \frac{0,098}{12} \right)^{-60} \right]}$ $= R1\ 522,71$	$\checkmark n = 60$ $\checkmark i = \frac{0,098}{12}$ \checkmark substitution of P \checkmark answer (4)
5.2.2	$OB = \frac{1522,71 \left[1 - \left(1 + \frac{0,098}{12} \right)^{-1,5 \times 12} \right]}{\frac{0,098}{12}}$ $= R25\ 393,30$	\checkmark substitution of x $\checkmark n = 1,5 \times 12 = 18$ \checkmark answer (3)

<p>5.2.3</p>	$R1522,71 \times (1,5 \times 12)$ $= R27408,78$ $\therefore R27408,78 - R25393,30$ $= R2015,48$ <p>Therefore by settling the amount he will save R2 015,48.</p>	<p>✓ R27408,78</p> <p>✓ R27408,78 – R25393,30</p> <p>✓ answer (3)</p>
<p>5.3</p>	$A = R793\,749,25 \left[1 + \frac{0,1025}{12} \right]^3$ $= R814\,263,3052$ <p>New instalments will therefore be calculated as follows:</p> $P = \frac{x[1 - (1 + i)^{-n}]}{i}$ $R814263,3052 = \frac{x \left[1 - \left(1 + \frac{0,1025}{12} \right)^{-231} \right]}{\frac{0,1025}{12}}$ $x = R8089,20$	<p>✓ R814 263,3052</p> <p>✓ substitution into P</p> <p>✓ $n = 231$</p> <p>✓ $\frac{0,1025}{12}$</p> <p>✓ answer (5)</p>
		<p>[18]</p>



QUESTION 6

<p>6.1</p>	$f(x+h) = -\frac{2}{x+h}$ $f'(x) = \lim_{h \rightarrow 0} \frac{-\frac{2}{x+h} - \left[-\frac{2}{x}\right]}{h}$ $= \lim_{h \rightarrow 0} \frac{-\frac{2}{x+h} + \frac{2}{x}}{h}$ $= \lim_{h \rightarrow 0} \frac{\frac{-2x + 2x + 2h}{x(x+h)}}{h}$ $= \lim_{h \rightarrow 0} \frac{2h}{x^2 + xh}$ $= \lim_{h \rightarrow 0} \frac{2}{x^2 + xh}$ $= \frac{2}{x^2}$	<p>✓ $f(x+h)$</p> <p>✓ substitution of $f(x+h)$</p> <p>✓ simplification</p> <p>✓ factoring h</p> <p>✓ answer (5)</p>
<p>6.2.1</p>	$y(x-2) = x^2 - 4$ $y(x-2) = (x-2)(x+2)$ $y = x+2$ $\frac{dy}{dx} = 1$	<p>✓ factors</p> <p>✓ $y = x+2$</p> <p>✓ answer (3)</p>
<p>6.2.2</p>	$D_x \left[\frac{2}{x^{\frac{3}{5}}} \right]$ $D_x \left[2x^{-\frac{3}{5}} \right]$ $= -\frac{6}{5} x^{-\frac{8}{5}}$	<p>✓ $\frac{2}{x^{\frac{3}{5}}}$</p> <p>✓ $2x^{-\frac{3}{5}}$</p> <p>✓ $\frac{6}{5} x^{-\frac{8}{5}}$</p> <p>(3)</p>
		<p>[11]</p>

QUESTION 7

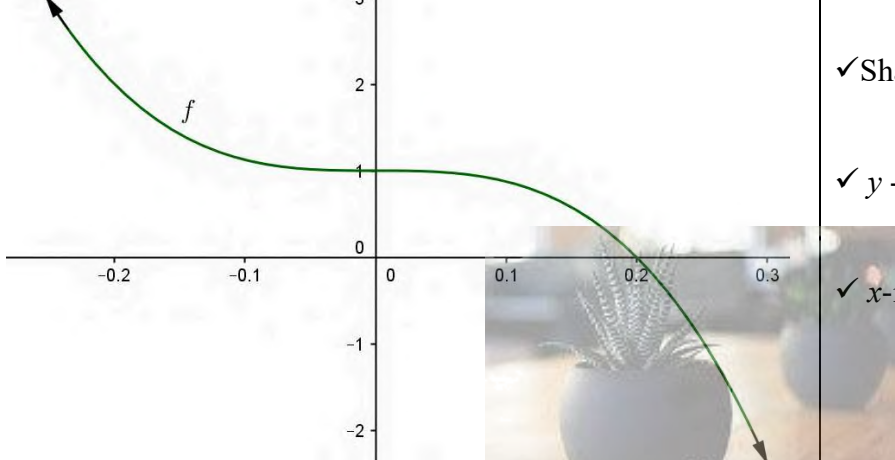
7.1	$f'(x) = 0$ $-3x^2 = 0$ $x = 0$ $\therefore y = 1$	✓ $f'(x) = 0$ ✓ (0;1) (2)
7.2	$f''(x) = 0$ $-750x = 0$ $x = 0$ $y = 1$ <p>Stationary point and point of inflection in this instance occur at same point.</p>	✓ $f''(x) = 0$ ✓ (0;1) (2)
7.2		✓ Shape ✓ y - intercept ✓ x-intercept (3)
7.3	$x < 0, x \in R$	✓ answer (1)
7.4	$f\left(\frac{1}{10}\right) = 1 - 125\left(\frac{1}{10}\right)^3$ $= \frac{7}{8}$ $f'\left(\frac{1}{10}\right) = -375\left(\frac{1}{10}\right)^2$ $= -\frac{15}{4}$ $y - \frac{7}{8} = -\frac{15}{4}\left(x - \frac{1}{10}\right)$ $y = -\frac{15}{4}x + \frac{5}{4}$	✓ $\frac{7}{8}$ ✓ $-\frac{15}{4}$ ✓ substitution ✓ equation (4)
		[12]

QUESTION 8

8.1	$V = \pi x^2 h = 440$ $\therefore h = \frac{440}{\pi x^2}$	✓ equated to 440 ✓ $h = \frac{440}{\pi x^2}$ (2)
8.2	$SA = 2\pi x^2 + 2\pi x h$ $SA = 2\pi x^2 + 2\pi x \left(\frac{440}{\pi x^2} \right)$ $= 2\pi x^2 + \frac{880}{x}$	✓ correct formula ✓ substitution of h (2)
8.3	$SA'(x) = 0$ $4\pi x - 880x^{-2} = 0$ $4\pi x = \frac{880}{x^2}$ $4\pi x^3 = 880$ $\therefore x = 4,12 \text{ cm}$	✓ $SA'(x) = 0$ ✓ derivative ✓ simplification ✓ answer (4) [8]



QUESTION 9

9.1	$P(A \text{ or } B) = P(A) + P(B) - P(A \text{ and } B)$ $0,57 = \frac{1}{2}P(B) + P(B) - 0$ $0,57 = \frac{3}{2}P(B)$ $P(B) = 0,38$	✓ $P(A \text{ and } B) = 0$ ✓ $P(A) = \frac{1}{2}P(B)$ ✓ substitute into addition rule ✓ answer (4)
9.2.1	$P(\text{First client takes a loaf of white bread}) = \frac{7}{12}$	✓ answer (1)
9.2.2	$P(BB) = \frac{5}{12} \times \frac{4}{11}$ $= \frac{20}{132} = \frac{5}{33}$	✓ $\frac{4}{11}$ ✓ multiplication ✓ $\frac{20}{132}$ (3)
9.2.3	<p style="text-align: center;">Branch 1 Branch 2</p> <p style="text-align: center;">$P(WB) \text{ or } P(BW) = \left(\frac{7}{12} \times \frac{6}{12}\right) + \left(\frac{5}{12} \times \frac{8}{12}\right) = \frac{41}{72}$</p>	✓ branch 1 ✓ branch 2 ✓ $\frac{7}{12} \times \frac{6}{12}$ and $\frac{5}{12} \times \frac{8}{12}$ ✓ answer (4)
9.3.1	$3 \times 5 = 15$	✓ answer (1)
9.3.2	$3 \times 5 \times 5 \times 3 = 225$	✓ $3 \times 5 \times 5 \times 3$ ✓ answer (2)
9.3.3	$3 \times 5 \times 4 \times 2 = 120$	✓✓ $3 \times 5 \times 4 \times 2$ (2)
		[17]

TOTAL MARKS: 150