



**education**

Department of  
Education  
FREE STATE PROVINCE

**EXAMINATION**

**GRADE 10**

**PHYSICAL SCIENCES**

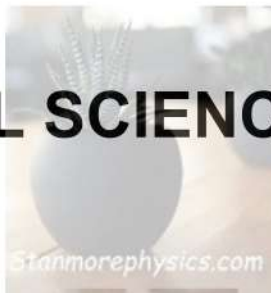

**JUNE 2026**

**MARKS: 150**

*Stanmorephysics.com*

**TIME: 3 HOURS**

**This paper consists of 17 pages and three information sheets.**

## INSTRUCTIONS AND INFORMATION

1. Write your name and other information in the appropriate spaces on the ANSWER BOOK.
2. This question paper consists of 11 questions. Answer ALL questions in the ANSWER BOOK.
3. Start EACH question on a NEW page in the ANSWER BOOK.
4. Number the answers correctly according to the numbering system used in this question paper.
5. Leave one line between two sub-questions, for example between QUESTION 2.1 and QUESTION 2.2.
6. You may use a non-programmable pocket calculator.
7. You may use appropriate mathematical instruments.
8. You are advised to use the attached DATA SHEETS.
9. Show ALL formulae and substitutions in ALL calculations.
10. Round off your FINAL numerical answers to a minimum of TWO decimal places where applicable.
11. Give brief motivations, discussions, et cetera where required.
12. Write neatly and legibly.



**QUESTION 1: MULTIPLE-CHOICE QUESTIONS**

Four options are provided as possible answers to the following questions. Each question has only ONE correct answer. Choose the answer and write down only the letter A, B, C or D next to the question number (1.1–1.10) in your ANSWER BOOK.

1.1 A single disturbance in a medium is called a ...

- A transposition.
- B wavefront.
- C amplitude.
- D pulse.

(2)

1.2 A sound wave moves at a speed of  $340 \text{ m}\cdot\text{s}^{-1}$  for  $t$  s. The correct wavelength and frequency of the wave is ...

	WAVELENGTH	FREQUENCY
A	$340t$	$\frac{1}{t}$
B	$\frac{340}{t}$	$t$
C	$340$	$\frac{1}{t}$
D	$340t$	$t$

(2)

1.3 The correct order of increasing penetrating ability of electromagnetic radiation is ...

- A gamma rays, ultraviolet, x-rays, microwaves.
- B microwaves, ultraviolet, x-rays, gamma rays.
- C ultraviolet, microwaves, gamma rays, x-rays.
- D microwaves, x-rays, ultraviolet, gamma rays.

(2)

- 1.4 Two identical metal spheres are brought into contact. Sphere **M** has a charge of **+P** and sphere **T** is neutral. The statement that best describes their charges after contact and separation is ...
- A each sphere has charge  $+\frac{1}{2}P$ .
- B sphere **T** becomes negatively charged.
- C sphere **M** loses all its charge to sphere **T**.
- D sphere **M** remains with **+P** and sphere **T** with zero. (2)

- 1.5 The correct equivalent unit for one volt is ...
- A  $C \cdot J^{-1}$ .
- B  $J \cdot C$ .
- C  $A \cdot \Omega^{-1}$ .
- D  $A \cdot \Omega$ . (2)

- 1.6 Learners want to investigate the effect of adding IDENTICAL resistors in parallel. They measure the resulting current each time. The graph indicating the correct relationship between the NUMBER OF RESISTORS ADDED IN PARALLEL (**Z**) and the current strength is ...

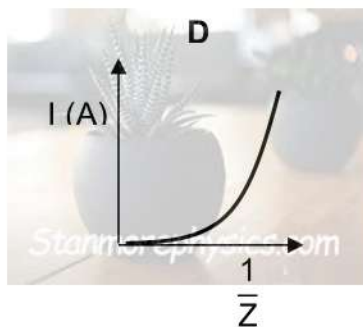
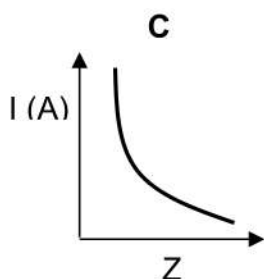
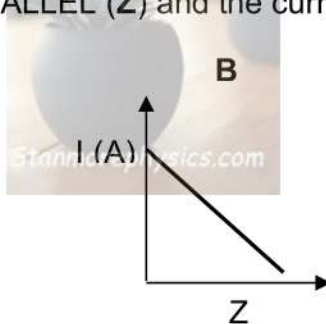
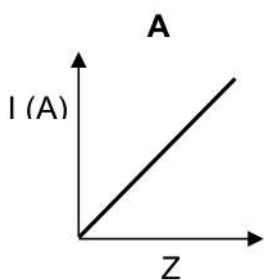

(2)

- 1.7 A sealed balloon filled with air is placed in a freezer. The volume of the balloon will ...
- A become the volume of the freezer container.  
B remain the same.  
C decrease.  
D increase. (2)

- 1.8 Element **Z** has an electron configuration as follows:  $1s^22s^22p^1$ . The element that is NOT an isotope of element **Z** is ...
- A  $X_5^{10}$   
B  $X_5^9$   
C  $X_4^5$   
D  $X_5^{12}$  (2)

- 1.9 The particle that identifies an ion of an element is a/an ...
- A electron.  
B positron.  
C neutron.  
D proton. (2)



- 1.10 Consider the following incomplete equation for a chemical reaction:

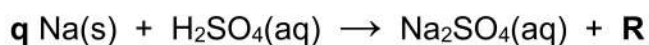

Letter **R** represents one of the products and letter **q** represents a numerical value which make the chemical equation correctly balanced.

The combination that COMPLETES the above chemical equation is...

	VALUE OF <b>q</b>	FORMULA OF <b>R</b>
A	2	2H
B	1	H <sub>2</sub> O
C	2	H <sub>2</sub>
D	1	H <sub>2</sub>

(2)  
[20]

**QUESTION 2**

Three waves, **A**, **B** and **C** are produced in a water tank. The possible frequency and wavelength of each is provided below. All three of the wave segments complete in  $t$  seconds and have an amplitude of  $x$  metres.

POSSIBLE FREQUENCY	POSSIBLE WAVELENGTH
12 Hz, 3 Hz, 6 Hz	10 cm, 20 cm, 5 cm

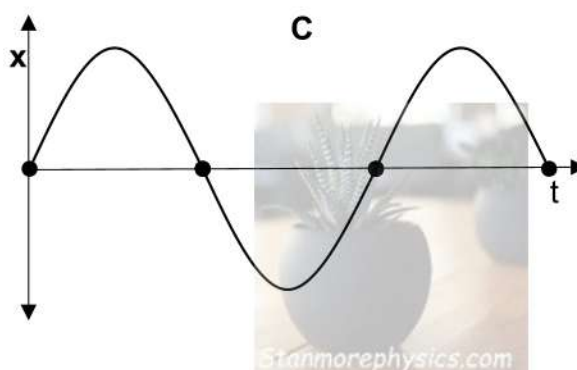
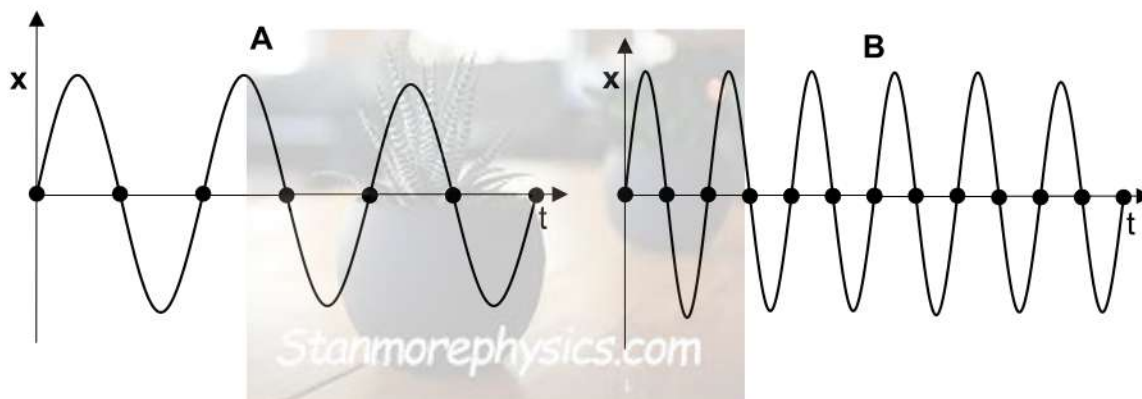

- 2.1 Name the type of wave represented by waves **A**, **B** and **C**. (1)
  - 2.2 Give a reason for the answer to QUESTION 2.1. (1)
  - 2.3 From the table above, choose the most suitable wavelength for wave **B**. Give a reason for the answer. (3)
  - 2.4 Calculate the speed of wave **A**, if it has frequency of 6 Hz and a wavelength 10 cm. (3)
  - 2.5 Sketch a labelled diagram of a longitudinal wave indicating the area of rarefaction and compression. (2)
- [10]**

### QUESTION 3

A car sounds a hooter near a standing learner. The distance between the car and learner is  $d$ . The sound reaches the learner after 1,6 s. Take the speed of sound in air as  $340 \text{ m}\cdot\text{s}^{-1}$ .

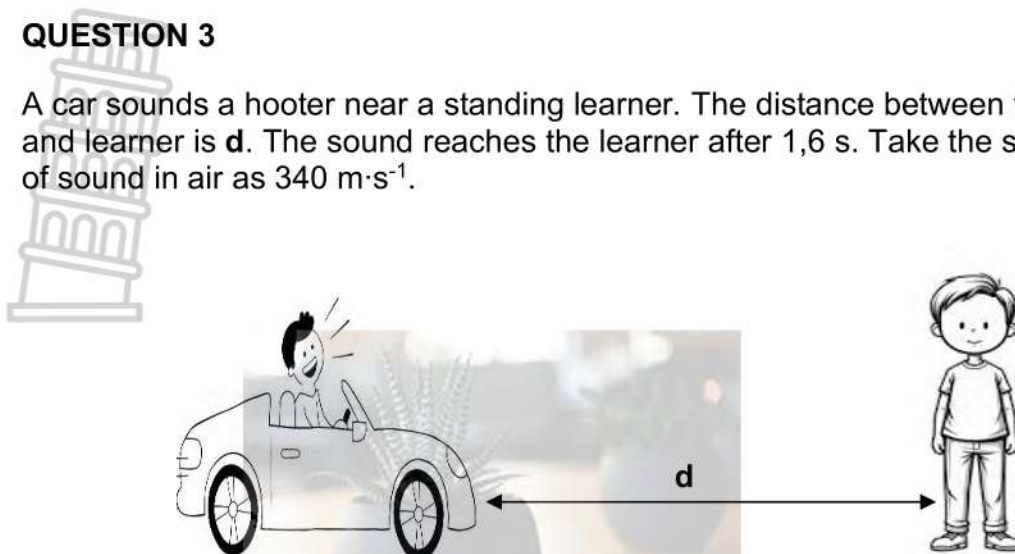

- 3.1 Calculate the distance,  $d$ . (3)
- 3.2 How would the speed of sound in water compare to that in air? Write down only HIGHER THAN, LOWER THAN or EQUAL TO. (1)

Ultrasound refers to sound with high frequencies and short wavelengths. These sounds are above the range of human hearing.

- 3.3 What is the highest value of the frequency that can be heard by the human ear. (1)
- 3.4 Give one medical application of ultrasound. (1)
- [6]**

**QUESTION 4**

The table below provides different types of electromagnetic radiation and their frequencies.



TYPE OF RADIATION	FREQUENCY (Hz)
X-ray	$2,5 \times 10^{18}$
Microwave	$7,0 \times 10^{10}$
Visible light	$7,5 \times 10^{14}$

- 4.1 Describe the dual nature of electromagnetic radiation. (2)
- 4.2 From the table above, write down the type of radiation with the most energy. (1)
- 4.3 Write down the reason for the answer in QUESTION 4.2. (2)

A radiologist sets a wavelength of 550 nm and identifies it as a green light wave.

- 4.4 Using calculations, determine by how much the radiologist must decrease the wavelength of green light in order to reach the wavelength of x-ray. (DO NOT ROUND OFF THE FINAL ANSWER.) (4)
- 4.5 X-ray and visible light are compared. How is the speed of visible light compared to that of x-ray. Write only (GREATER THAN, EQUAL TO or LESS THAN) (1)

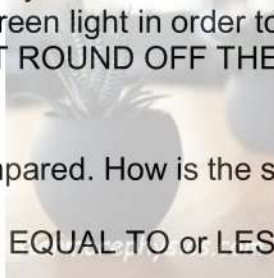

The three electromagnetic waves in the table above could be dangerous to humans with overexposure.

- 4.6 Identify the type of radiation that is MOST dangerous AND explain why this radiation is dangerous to the skin. (2)
- [12]**

**QUESTION 5**

A small neutral sphere **M** acquires a charge of  $-1,95 \times 10^{-6} \text{ C}$ .

5.1 Were electrons ADDED TO or REMOVED FROM the sphere? (1)

5.2 Calculate the number of electrons which were added or removed. (3)

An identical sphere **N** of unknown charge is placed next to the sphere of charge  $-1,95 \times 10^{-6} \text{ C}$ . The two spheres are allowed to touch as shown.

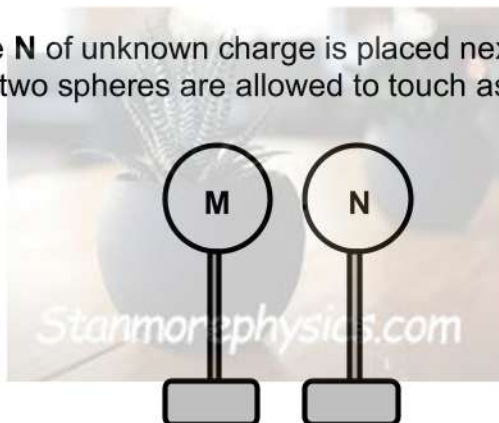

After separation, it is found that each sphere has a charge of  $+1,53 \times 10^{-6} \text{ C}$ .

5.3 State the principle of conservation of charge in words. (2)

Calculate the:

5.4 Charge of the unknown sphere **N**. (4)

5.5 Charge gained or lost by the spheres ( $\Delta Q$ ). (2)

**[12]**

**QUESTION 6**

Consider the circuit diagram below. The battery is connected to an ammeter  $A_1$ , a switch  $S_1$ , a  $2\ \Omega$  light bulb and two IDENTICAL resistors,  $R_1$  and  $R_2$ , as shown. The EMF of the battery is  $24\ V$ .

Ammeter  $A_2$  reads the current passing through  $R_2$ .

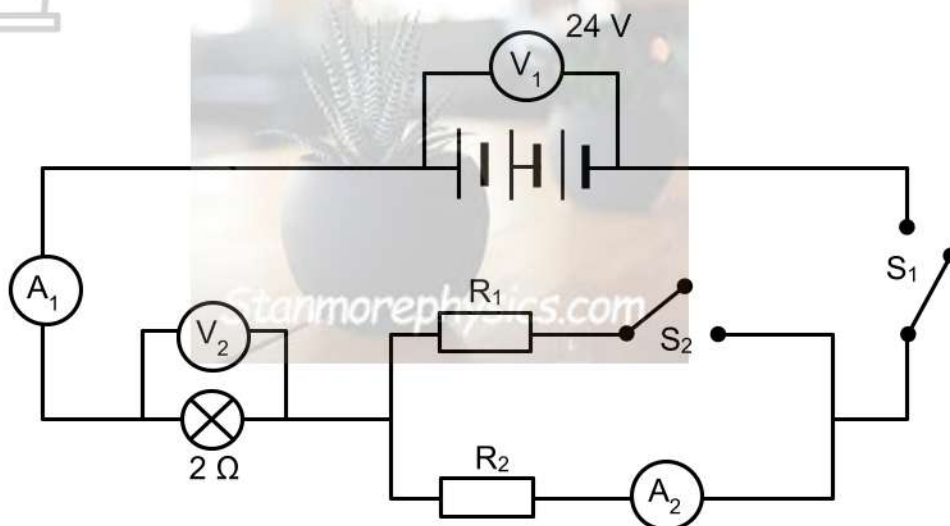

- 6.1 Define the term *EMF*. (2)
- 6.2 What is the EMF of one individual cell? (2)
- 6.3 Switch  $S_1$  is closed while  $S_2$  REMAINS OPEN. If the value of  $V_2$  is known, show how you would calculate the potential difference across resistor  $R_2$ . (1)

It is then further known that ammeter  $A_1$  has an initial reading of  $3\ A$  when ONLY switch  $S_1$  is closed,  $S_2$  REMAINS OPEN and the circuit runs for 4 minutes.

Calculate the following:

- 6.4 The reading on  $V_2$  (3)
- 6.5 The energy used by the  $2\ \Omega$  bulb. (4)
- 6.6 The resistance of  $R_2$  (4)

The circuit on the previous page is REDRAWN for easy reference.

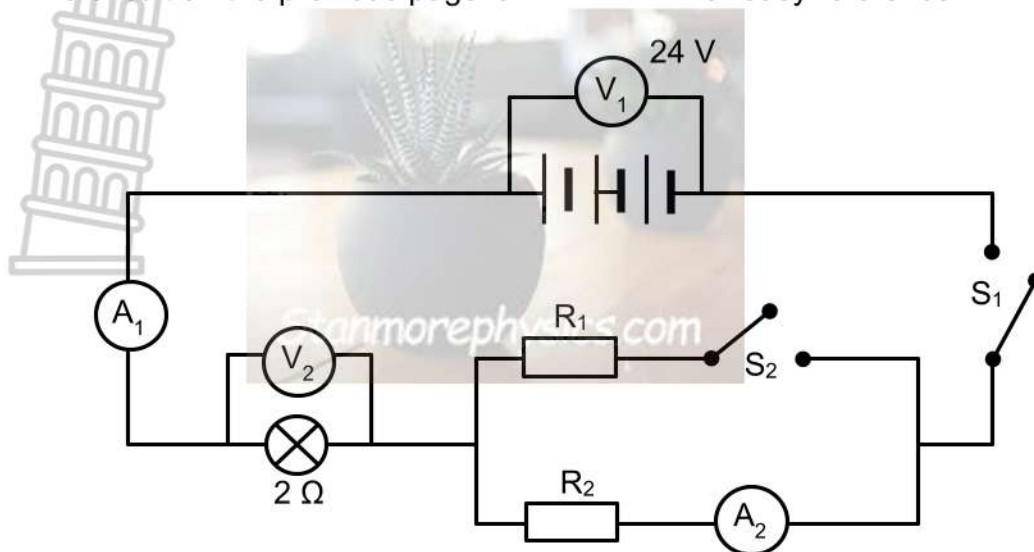

Switch  $S_2$  is now ALSO CLOSED.

- 6.7 What would be the effect on the reading of ammeter  $A_1$ ? Write down only INCREASES, DECREASES or REMAINS THE SAME. Explain the answer. (3)
- 6.8 Calculate the total resistance of the circuit. (4)
- 6.9 Learners investigate how the connection of resistors affect the main current. Circuit **A** has two bulbs connected in series. Circuit **B** has two bulbs connected in parallel. All bulbs have equal resistance,  $X$ . The EMF of both batteries is 12 V.

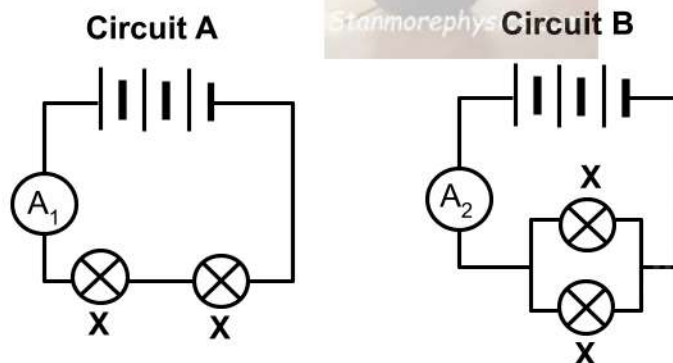

Determine the **ratio** of current  $A_1:A_2$  (4)  
**[27]**

### QUESTION 7

7.1 The table below shows the boiling and melting points of substances **W** to **Z**.

SUBSTANCE	MELTING POINT (°C)	BOILING POINT (°C)
<b>W</b>	-39	357
<b>X</b>	-210	-196
<b>Y</b>	801	1413
<b>Z</b>	-95	65

7.1.1 Define the term *melting point*. (2)

7.1.2 From the table above, write down the physical state of:

(a) Substance **W** at  $-50\text{ }^{\circ}\text{C}$ ? (1)

(b) Substance **Z** at  $60\text{ }^{\circ}\text{C}$ ? (1)



7.2 The heating curve of a substance is shown below

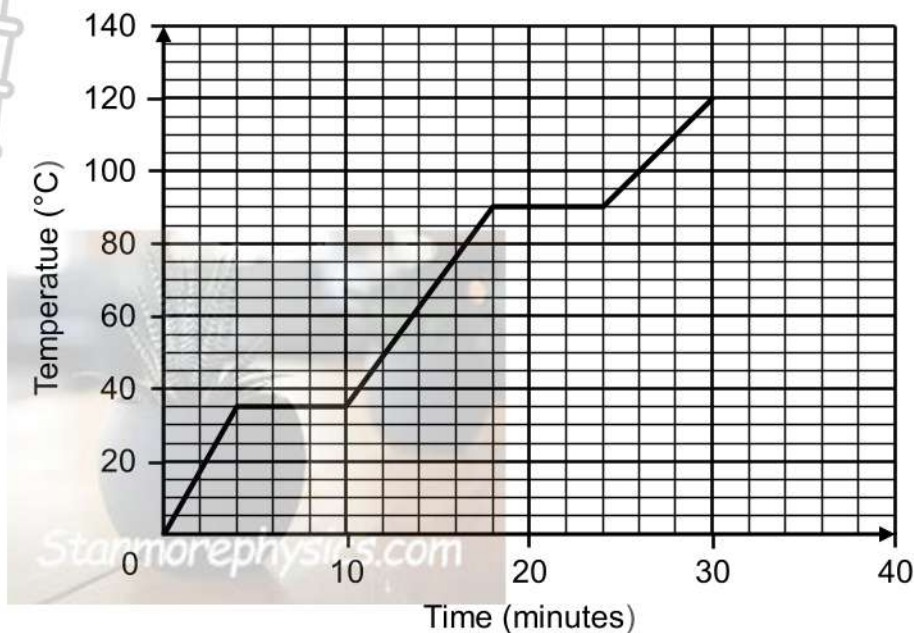

7.2.1 Write down the boiling point of the above substance. (1)

7.2.2 What will happen to the average kinetic energy of the substance's particles during the time intervals below?

Write down only INCREASES, DECREASES or REMAINS THE SAME.

(a)  $t = 0$  minutes and  $t = 4$  minutes (1)

(b)  $t = 5$  minutes and  $t = 10$  minutes (1)

7.2.3 Use the kinetic molecular theory to fully explain the answer to QUESTION 7.2.2(a). Refer to the energy, movement and forces between particles in the explanation. (3)  
**[10]**

**QUESTION 8**

The bar graph below represents three elements in the periodic table, with their subatomic particles.

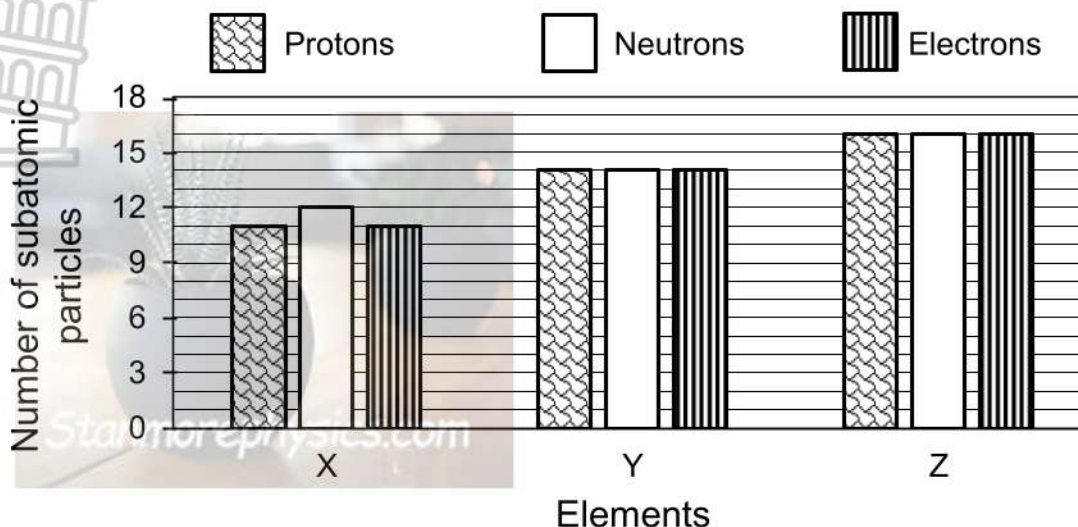

8.1 Define the term *atomic number*. (2)

8.2 Consider element **Y**.

8.2.1 Write down its chemical NAME or SYMBOL. (1)

8.2.2 Draw its Aufbau diagram. (3)

8.3 Write down a term used for the most probable region in space where electrons are found. (1)

8.4 Write down the number of valence electrons in element **Z**. (2)

8.5 Below is a representation of the periodic table with positions **1 to 7** indicated.

			4		6	
1	2		3	5	7	

Which ONE of the three positions resembles the actual position of element **X**? Explain the answer. (3)

8.6 Element **X** and **Z** form a chemical bond. Write down the chemical formula of this compound. (2)

8.7 Element **X** has two isotopes. In a sample, **X-23** has 78,9% abundance and **X-24** has 21,1% abundance. Calculate the relative atomic mass of the element **X**. (3)

[17]

### QUESTION 9

The diagrams below represent two elements in the periodic table, with the same number of valence electrons. Element **A** has 15 protons while element **B** has 7 protons.

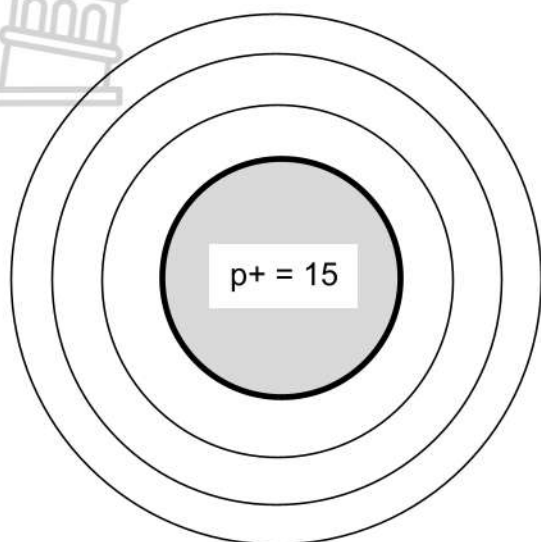

**Element A**

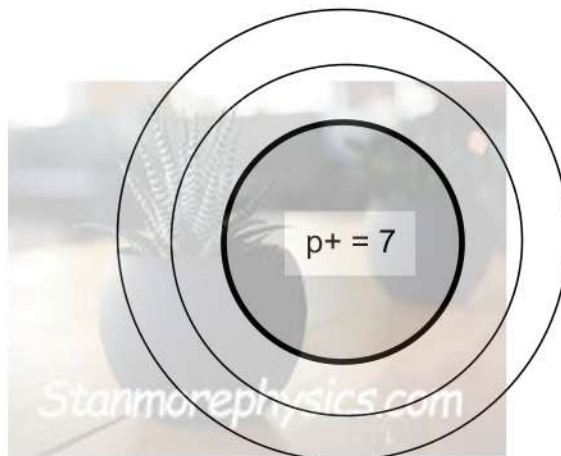

**Element B**

- 9.1 Define the term *ionisation energy*. (2)
- 9.2 Which of the two elements, **A** or **B**, has a greater ionisation energy? (1)
- 9.3 Explain the answer to QUESTION 9.2. (2)
- 9.4 Write down the group number to which these elements belong. (1)
- 9.5 Write down the CHEMICAL FORMULA for the ION of element **A**. (2)
- 9.6 Is the ion referred to in QUESTION 9.5 an ANION or a CATION? Explain the answer in term of electron transfer. (2)
- [10]**

### QUESTION 10

Five substances (**A-E**) are shown in the table below.

A	B	C	D	E
Sodium chloride	Oxygen gas	Cobalt	Water	$\text{Fe}_2(\text{SO}_4)_3$

10.1 Which kind of bond exists between the atoms of the following substances?

10.1.1 A (1)

10.1.2 B (1)

10.1.3 C (1)

10.2 Write down the letter (**A-E**) of the substance that...

10.2.1 CANNOT conduct electricity. (1)

10.2.2 is magnetic. (1)

10.3 Atoms of substance **D** are bonded by covalent bonds.

10.3.1 Define the term *covalent bond*. (2)

10.3.2 Draw the Lewis diagram for substance **D**. (2)

10.4 Consider substance **E**.

10.4.1 Write down its full chemical name. (2)

10.4.2 How many atoms of each element are present in one formula unit of  $\text{Fe}_2(\text{SO}_4)_3$  (3)

10.4.3 Write down the formulae of iron and sulphate ions that form  $\text{Fe}_2(\text{SO}_4)_3$ . (2)

**[16]**

### QUESTION 11

Study the following reactions and answer the questions that follow.

<b>Reaction A</b>	hydrochloric acid + magnesium → salt <b>X</b> + gas <b>Y</b>
<b>Reaction B</b>	$2\text{NH}_3(\text{g}) \rightarrow \text{N}_2(\text{g}) + 3\text{H}_2(\text{g})$
<b>Reaction C</b>	$\text{CO}_2(\text{s}) \rightarrow \text{CO}_2(\text{g})$
<b>Reaction D</b>	$\text{CH}_4(\text{g}) + \text{O}_2(\text{g}) \rightarrow \text{CO}_2(\text{g}) + 2\text{H}_2\text{O}(\text{g})$

- 11.1 Reaction **A** is an exothermic chemical reaction.
- 11.1.1 Define the term *chemical change*. (2)
- 11.1.2 Write down ONE way that you would observe that this reaction is a chemical change. (1)
- 11.2 Use the Law of conservation of mass, with appropriate calculations, to prove that reaction **B** is correctly balanced. (3)
- 11.3 During reaction **C**, carbon dioxide undergoes a change.
- 11.3.1 Is it a PHYSICAL or CHEMICAL change? (1)
- 11.3.2 Is this reaction an example of CONDENSATION, SUBLIMATION or PRECIPITATION? (1)
- 11.3.3 Would this reaction require MORE or LESS energy to take place compared to reaction **D**? Write down the reason for the answer. (2)
- [10]**

**GRAND TOTAL: 150**

**DATA FOR PHYSICAL SCIENCES GRADE 10 (PHYSICS)  
 JUNE EXAMINATION - TERM 2**

**GEGEWENS VIR FISIESE WETENSAPPE GRAAD 10 (FISIKA)  
 JUNIE-EKSAMEN - KWARTAAL 2**

**TABLE 1: PHYSICAL CONSTANTS / TABEL 1: FISIESE KONSTANTES**

NAME / NAAM	SYMBOL / SIMBOOL	VALUE / WAARDE
Acceleration due to gravity <i>Swaaartekragversnelling</i>	g	9,8 m·s <sup>-1</sup>
Speed of light in a vacuum <i>Spoed van lig in 'n vakuum</i>	c	3,0 x 10 <sup>8</sup> m·s <sup>-1</sup>
Planck's constant <i>Planck se konstante</i>	h	6,63 x 10 <sup>-34</sup> J·s
Charge on electron <i>Lading op elektron</i>	e	-1,6 x 10 <sup>-19</sup> C
Electron mass <i>Elektronmassa</i>	m <sub>e</sub>	9,11 x 10 <sup>-31</sup> kg

**TABLE 2: FORMULAE / TABEL 2: FORMULES**

**WAVES, SOUND AND LIGHT / GOLWE, KLANK EN LIG**

$v = f\lambda$	$f = \frac{1}{T}$ OR/OR $T = \frac{1}{f}$
$v = \frac{\Delta x}{\Delta t}$	OF/OR $E = hf$ OR/OR $E = h\frac{c}{\lambda}$
speed = $\frac{\text{distance}}{\text{tyd}}$	
spoed = $\frac{\text{afstand}}{\text{tyd}}$	

**ELECTROSTATICS / ELEKTROSTATIKA**

$n = \frac{Q}{e}$	$Q = \frac{Q_1 + Q_2}{2}$
-------------------	---------------------------

**ELECTRIC CIRCUITS/ ELEKTRIESE STROOMBANE**

$I = \frac{Q}{\Delta t}$	$R = \frac{V}{I}$
$V = \frac{W}{Q}$	$R_s = R_1 + R_2 + \dots$
$\frac{1}{R_p} = \frac{1}{R_1} + \frac{1}{R_2} + \dots$	



**DATA FOR PHYSICAL SCIENCES GRADE 10 (CHEMISTRY)  
 JUNE EXAMINATION - TERM 2**

**GEGEWENS VIR FISIESTE WETENSKAPPE GRAAD 10 (CHEMIE)  
 JUNIE-EKSAMEN - KWARTAAL 2**

**TABLE 1: PHYSICAL CONSTANTS / TABEL 1: FISIESTE KONSTANTES**

NAME / NAAM	SYMBOL / SIMBOOL	VALUE / WAARDE
Standard temperature <i>Standaarddruk</i>	$p^\theta$	$1,013 \times 10^5 \text{ Pa}$
Molar gas volume at STP <i>Molêre gasvolume by STD</i>	$V_m$	$22,4 \text{ dm}^3 \cdot \text{mol}^{-1}$
Standard temperature <i>Standaardtemperatuur</i>	T	273 K
Charge on electron <i>Lading op elektron</i>	e	$-1,6 \times 10^{-19} \text{ C}$
Avogadro's constant <i>Avogadro-konstante</i>	$N_A$	$6,02 \times 10^{23} \text{ mol}^{-1}$

**TABLE 2: FORMULAE / TABEL 2: FORMULES**

$n = \frac{m}{M}$		$n = \frac{N}{N_A}$
$c = \frac{n}{V}$ OR/OF $c = \frac{m}{MV}$		$n = \frac{V}{V_m}$

TABLE 3: THE PERIODIC TABLE OF ELEMENTS/TABEL 3: DIE PERIODIEKE TABEL VAN ELEMENTE

1 (I)	2 (II)	3	4	5	6	7	8	9	10	11	12	13 (III)	14 (IV)	15 (V)	16 (VI)	17 (VII)	18 (VIII)
1 2,1 1 <b>H</b>																	2 He 4
3 1,0 7 <b>Li</b>	4 1,5 9 <b>Be</b>											5 2,0 11 <b>B</b>	6 2,5 12 <b>C</b>	7 3,0 14 <b>N</b>	8 3,5 16 <b>O</b>	9 4,0 19 <b>F</b>	10 Ne 20
11 0,9 23 <b>Na</b>	12 1,2 24 <b>Mg</b>											13 1,5 27 <b>Al</b>	14 1,8 28 <b>Si</b>	15 2,1 31 <b>P</b>	16 2,5 32 <b>S</b>	17 3,0 35,5 <b>Cl</b>	18 Ar 40
19 0,8 39 <b>K</b>	20 1,0 40 <b>Ca</b>	21 1,3 45 <b>Sc</b>	22 1,5 48 <b>Ti</b>	23 1,6 51 <b>V</b>	24 1,6 52 <b>Cr</b>	25 1,5 55 <b>Mn</b>	26 1,8 56 <b>Fe</b>	27 1,8 59 <b>Co</b>	28 1,8 59 <b>Ni</b>	29 1,9 63,5 <b>Cu</b>	30 1,6 65 <b>Zn</b>	31 1,6 70 <b>Ga</b>	32 1,8 73 <b>Ge</b>	33 2,0 75 <b>As</b>	34 2,4 79 <b>Se</b>	35 2,8 80 <b>Br</b>	36 Kr 84
37 0,8 86 <b>Rb</b>	38 1,0 88 <b>Sr</b>	39 1,2 89 <b>Y</b>	40 1,4 91 <b>Zr</b>	41 92 <b>Nb</b>	42 1,8 96 <b>Mo</b>	43 1,9 96 <b>Tc</b>	44 2,2 101 <b>Ru</b>	45 2,2 103 <b>Rh</b>	46 2,2 106 <b>Pd</b>	47 1,9 108 <b>Ag</b>	48 1,7 112 <b>Cd</b>	49 1,7 115 <b>In</b>	50 1,8 119 <b>Sn</b>	51 1,9 122 <b>Sb</b>	52 2,1 128 <b>Te</b>	53 2,5 127 <b>I</b>	54 Xe 131
55 0,7 133 <b>Cs</b>	56 0,9 137 <b>Ba</b>	57 139 <b>La</b>	72 1,6 179 <b>Hf</b>	73 181 <b>Ta</b>	74 184 <b>W</b>	75 186 <b>Re</b>	76 190 <b>Os</b>	77 192 <b>Ir</b>	78 195 <b>Pt</b>	79 197 <b>Au</b>	80 201 <b>Hg</b>	81 1,8 204 <b>Tl</b>	82 1,8 207 <b>Pb</b>	83 1,9 209 <b>Bi</b>	84 2,0 209 <b>Po</b>	85 2,5 209 <b>At</b>	86 Rn 222
87 0,7 Fr	88 0,9 226 Ra	89 Ac															
			58 140 <b>Ce</b>	59 141 <b>Pr</b>	60 144 <b>Nd</b>	61 <b>Pm</b>	62 150 <b>Sm</b>	63 152 <b>Eu</b>	64 157 <b>Gd</b>	65 159 <b>Tb</b>	66 163 <b>Dy</b>	67 165 <b>Ho</b>	68 167 <b>Er</b>	69 169 <b>Tm</b>	70 173 <b>Yb</b>	71 175 <b>Lu</b>	
			90 232 <b>Th</b>	91 <b>Pa</b>	92 238 <b>U</b>	93 <b>Np</b>	94 <b>Pu</b>	95 <b>Am</b>	96 <b>Cm</b>	97 <b>Bk</b>	98 <b>Cf</b>	99 <b>Es</b>	100 <b>Fm</b>	101 <b>Md</b>	102 <b>No</b>	103 <b>Lr</b>	

KEY/SLEUTEL

Atomic number  
Atoomgetal

Electronegativity  
Elektronegatiwiteit

Symbol  
Simbool

Approximate relative atomic mass  
Benaderde relatiewe atoommassa



# education

Department of  
Education  
FREE STATE PROVINCE

**EXAMINATION/EKSAMEN**

**GRADE/GRAAD 10**

**PHYSICAL SCIENCES/  
FISIESE WETENSKAPPE**

**JUNE/JUNIE 2026**

**MARKING GUIDELINE/  
NASIENRIGLYNE**

**MARKS/PUNTE: 150**

This marking guideline consists of 13 pages.

*Hierdie nasienriglyn beslaan 13 bladsye.*

**QUESTION 1: MULTIPLE-CHOICE QUESTIONS**  
**VRAAG 1: VEELVULDIGE KEUSEVRAE**

- 1.1 D ✓✓ (2)
- 1.2 A ✓✓ (2)
- 1.3 B ✓✓ (2)
- 1.4 A ✓✓ (2)
- 1.5 D ✓✓ (2)
- 1.6 A ✓✓ (2)
- 1.7 C ✓✓ (2)
- 1.8 C ✓✓ (2)
- 1.9 A ✓✓ (2)
- 1.10 C ✓✓ (2)
- [20]**

**QUESTION 2**

- 2.1 Transverse (wave) / *Transversale (golf)* ✓ (1)
- 2.2 The particles of the medium vibrate at right angles to the direction of motion of the wave ✓ / *Die deeltjies van die medium vibreer loodreg op die bewegingsrigting van die golf.*  
**Accept/Aanvaar:**  
The disturbance is at right angles to the direction of propagation (motion) of the wave. / *Die versteuring is loodreg op die rigting van voortplanting (beweging) van die golf.* (1)
- 2.3 5 cm ✓  
It has the highest frequency/smallest period ✓ and shortest wavelength ✓ / *Dit het die hoogste frekwensie/kleinste periode ✓ en kortste golflengte ✓*
- OR/OF**  
5cm ✓,  $f \propto \frac{1}{\lambda}$  ✓✓ (3)

2.4

OPTION/OPSIE 1	OPTION/OPSIE 2
$v = f\lambda \checkmark$ $= 6(0,1) \checkmark$ $= 0,6 \text{ m}\cdot\text{s}^{-1} \checkmark$  <b>IF:</b> $c = f\lambda$ is used, max. $\frac{2}{3}$	$T = \frac{1}{f}$ $= \frac{1}{6}$ $= 0,167 \text{ s}$ $\text{speed} = \frac{\text{distance}}{\text{time}} \checkmark$ $= \frac{0,1}{0,167} \checkmark$ $= 0,6 \text{ m}\cdot\text{s}^{-1} \checkmark$ $\text{spoed} = \frac{\text{afstand}}{\text{tyd}}$

(3)

2.5

**MARKING CRITERIA/ MERKRIGLYNE**

- ✓ correct shape/ korrekte vorm  
(**Accept:** straight lines in the drawing. / **Aanvaar:** reguitlynskets.)
- ✓ correct labelling/ korrekte ettiketering

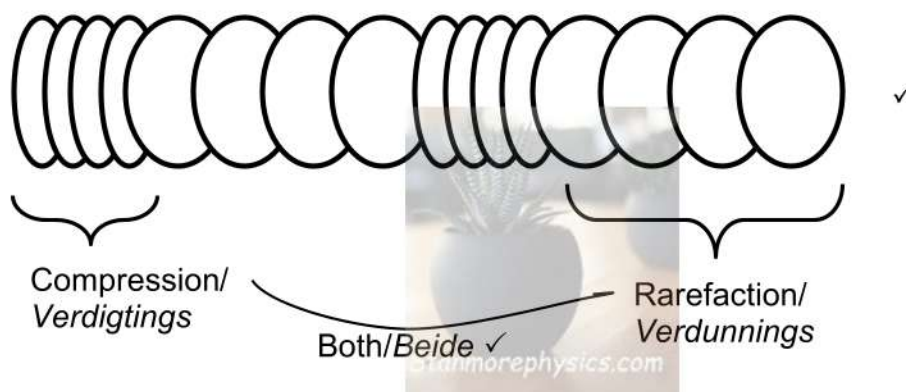

(2)  
[10]

**QUESTION/VRAAG 3**

- 3.1  $v = \frac{\Delta x}{\Delta t} \checkmark$  **OR/OF** speed =  $\frac{\text{distance}}{\text{time}}$  / spoed =  $\frac{\text{afstand}}{\text{tyd}}$   
 $340 = \frac{\Delta x}{1,6} \checkmark$   
 $\Delta x = 544 \text{ m} \checkmark$  (3)
- 3.2 HIGHER THAN  $\checkmark$  / HOËR AS (1)
- 3.3 20 kHz  $\checkmark$  **OR/OF** 20 000 Hz (1)
- 3.4 **(Accept any ONE relevant application)/ (Aanvaar enige EEN toepassing.)**  
 Sonar image of an unborn baby. / Sonar van 'n ongebore baba.  $\checkmark$   
 To measure the rate of blood flow. / Om bloedvloei te meet.  
 To break down gallstones and kidney stones. / Om galstene en nierstene te breek.  
 Used by dentists to clean teeth. / Word deur tandartse gebruik om tande skoon te maak. (1)
- [6]**

**QUESTION/ VRAAG 4**

- 4.1 Behaves as both particle  $\checkmark$  and wave  $\checkmark$   
 Dit het deeltjie sowel as golfgeaardheid. (2)
- 4.2 X-ray/ X-straal  $\checkmark$  (1)
- 4.3 According to/ Volgens:  $E = hf$   
 $E \propto f \checkmark \checkmark$  **OR/OF**  
 The higher the frequency, the higher the energy.  $\checkmark \checkmark$   
 Hoe hoër die frekwensie, hoe hoër die energie (2)
- 4.4  $c = f\lambda \checkmark$   
 $3 \times 10^8 = 2,5 \times 10^{18} \lambda \checkmark$   
 $\lambda = 1,2 \times 10^{-10} \text{ m for x-ray (0,12 nm)}$   
 Adjustment/ Verstelling:  
 $= 550 \times 10^{-9} - 1,2 \times 10^{-10} \checkmark$  **OR/OF**  $550 \text{ nm} - 0,12 \text{ nm}$   
 $= 549,88 \times 10^{-9} \text{ m} \checkmark$  **OR/OF**  $= 549,88 \text{ nm}$  (4)
- 4.5 EQUAL TO/ GELYK AAN  $\checkmark$  (1)
- 4.6 X-ray/ X-strale.  $\checkmark$   
 It could cause severe skin/ tissue damage  $\checkmark$  /  
 Dit kan erge vel/weefsel skade aanrig. (2)
- [12]**

**QUESTION/VRAAG 5**

5.1 Added / By gevoeg ✓ (1)

5.2  $n = \frac{Q}{q_e} \checkmark$   
 $= \frac{1,95 \times 10^{-6}}{1,6 \times 10^{-19}} \checkmark$   
 $= 1,22 \times 10^{13} e^- \checkmark$  (3)

5.3 The net charge of an isolated system remains constant during any physical process. ✓✓ (2 or 0)

**ACCEPT:**

Charge cannot be created or destroyed but can only be transferred from one object to another.

*Die nettolading in 'n geïsoleerde sisteem bly konstant tydens enige fisiese proses.*

**AANVAAR:**

Lading kan nie geskep of vernietig word nie, maar slegs van een voorwerp na 'n ander oorgedra word. (2)

5.4

$$Q_{\text{new}} = \frac{Q_1 + Q_2}{2} \checkmark$$

$$1,53 \times 10^{-6} \checkmark = \frac{-1,95 \times 10^{-6} + Q_N}{2} \checkmark$$

$$Q_N = 5,01 \times 10^{-6} \text{ C} \checkmark \quad (\text{Accept } 5,01 \mu\text{C})$$

**AFRIKAANS VERSION:**

$$Q_{\text{new}} = \frac{Q_1 + Q_2}{2} \checkmark$$

$$1,53 \times 10^{-6} \checkmark = \frac{-1 \times 10^{-6} + Q_N}{2} \checkmark$$

$$Q_N = 4,06 \times 10^{-6} \text{ C} \checkmark \quad (\text{Accept } 4,06 \mu\text{C}) \quad (4)$$

5.5 POSITIVE MARKING FROM QUESTION 5.4 /  
POSITIEWE NASIEN VANAF VRAAG 5.4



OPTION 1	OPTION 2
$\Delta Q = Q_f - Q_i$ $= 1,53 \times 10^{-6} - 5,01 \times 10^{-6} \checkmark$ $= -3,48 \times 10^{-6} \text{ C } \checkmark$ <b>Accept: -3,48 <math>\mu\text{C}</math></b>	$\Delta Q = Q_f - Q_i$ $= 1,53 \times 10^{-6} - (-1,95 \times 10^{-6}) \checkmark$ $= 3,48 \times 10^{-6} \text{ C } \checkmark$ <b>Accept: 3,48 <math>\mu\text{C}</math></b>
<b>AFRIKAANS VERSION</b> $\Delta Q = Q_f - Q_i$ $= 1,53 \times 10^{-6} - 4,06 \times 10^{-6} \checkmark$ $= -2,53 \times 10^{-6} \text{ C } \checkmark$ <b>Accept: -2,53 <math>\mu\text{C}</math></b>	$\Delta Q = Q_f - Q_i$ $= 1,53 \times 10^{-6} - (-1 \times 10^{-6}) \checkmark$ $= 2,53 \times 10^{-6} \text{ C } \checkmark$ <b>Accept: 2,53 <math>\mu\text{C}</math></b>

(2)  
[12]

QUESTION/VRAAG 6

6.1 The (total) work done per unit charge (by the battery).  $\checkmark\checkmark$  (2 or 0)  
Die (totale) arbeid verrig per eenheid lading (deur die battery). (2)

6.2  $24 \text{ V} \div 3 \checkmark = 8 \text{ V } \checkmark$  (2)

6.3  $V_{R_2} = \underline{24 - V_2} \checkmark$  (1)

6.4  $V = IR \checkmark$   
 $= 3 (2) \checkmark$   
 $= 6 \text{ V } \checkmark$  (3)

6.5 POSITIVE MARKING FROM QUESTION 6.4 /  
POSITIEWE NASIEN VANAF VRAAG 6.4

OPTION/ OPSIE 1	OPTION/ OPSIE 2
$Q = I\Delta t$ $= 3 (4 \times 60) \checkmark$ $= 720 \text{ C}$ $W = VQ \checkmark$ $= 6 (720) \checkmark$ $= 4\,320 \text{ J } \checkmark$	$W = VI\Delta t \checkmark$ $= 6 (3) \checkmark (4 \times 60 \checkmark)$ $= 4\,320 \text{ J } \checkmark$

(4)

6.6 **POSITIVE MARKING FROM QUESTION 6.3 & 6.4 /  
POSITIEWE NASIEN VANAF 6.3 & 6.4**



OPTION/ OPSIE 1	OPTION/ OPSIE 2
$R_{\text{tot}} = \frac{V_{\text{tot}}}{I} \checkmark$ $= \frac{24}{3} \checkmark$ $= 8 \Omega$ $R_{\text{tot}} = R_{\text{bulb}} + R_2$ $8 = 2 + R_2 \checkmark$ $R_2 = 6 \Omega \checkmark$	$V_{R_2} = V_{\text{tot}} - V_2$ $= 24 - 6 \checkmark$ $= 18 \text{ V}$ $R_2 = \frac{V}{I} \checkmark$ $= \frac{18}{3} \checkmark$ $= 6 \Omega \checkmark$

(4)

6.7 Increases / *Toeneem* ✓

Total resistance decreases, ✓ the EMF remains the same ✓ so total current therefore increases.

*Totale weerstand neem af, EMK verander nie, totale stroom neem toe.*

(3)

6.8 **POSITIVE MARKING FROM QUESTION 6.6 /  
POSITIEWE NASIEN VANAF VRAAG 6.6**

$$\frac{1}{R_p} = \frac{1}{R_1} + \frac{1}{R_2} \checkmark$$

$$\frac{1}{R_p} = \frac{1}{6} + \frac{1}{6} \checkmark$$

$$R_p = 3 \Omega$$

$$\downarrow$$

$$R_{\text{tot}} = 3 + 2 \checkmark$$

$$= 5 \Omega \checkmark$$



(4)

6.9 Series:

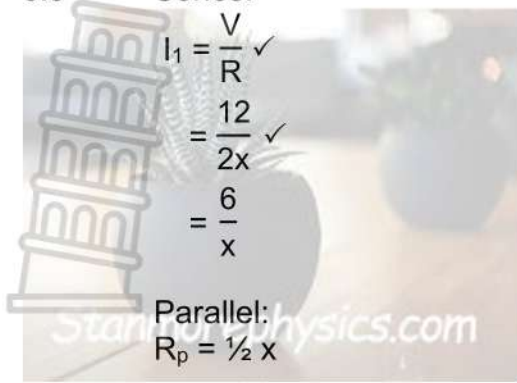

Parallel:

$$R_p = \frac{1}{2} x$$

$$I_2 = \frac{12}{\frac{1}{2} x} \checkmark$$
$$= \frac{24}{x}$$

Ratio/Verhouding:  $I_{\text{series}} : I_{\text{Parallel}}$

$$\frac{6}{x} : \frac{24}{x}$$
$$1 : 4 \checkmark$$

(4)  
[27]



**QUESTION 7**

7.1.1 The temperature at which a solid, given sufficient heat, becomes a liquid. ✓✓ / Die temperatuur waarteen 'n vaste stof, met voldoende hitte, 'n vloeistof word.

**OR**

The temperature at which the solid and liquid phases of a substance are at equilibrium. / Die temperatuur waarteen die vastestof en vloeistoffases van 'n stof in ewewig is. (2)

7.1.2 (a) Solid/ Vatstestof ✓.com (1)

(b) Liquid/ Vloeistof ✓ (1)

7.2.1 90 (°C) ✓ (1)

7.2.2 (a) INCREASES/ TOENEEM ✓ (1)

(b) REMAINS THE SAME/ BLY DIESELFDE ✓ (1)

7.2.3 As a substance is heated, its particles absorb energy. ✓  
The particles move faster. ✓  
The forces of attraction between the particles become weaker. ✓

Soos wat 'n stof verwarm word, absorber deeltjies energie.  
Die deeltjies beweeg vinniger.  
Die aantrekkingskragte tussen deeltjies verswak.

(3)  
**[10]**

**QUESTION/VRAAG 8**

8.1 Number of protons in an atom of an element. ✓✓ (2 or 0) (2)  
 Die aantal protone in 'n atom van 'n element.

8.2.1 Silicon/ Si ✓ (1)

8.2.2 **MARKING CRITERIA/ MERKRIGLYNE**

- Correct labelling of energy levels: 1s 2s 2p 3s 3p ✓  
 Korrekte benoeming van energievlakke: 1s 2s 2p 3s 3p
- Correct filling of 1<sup>st</sup> and 2<sup>nd</sup> energy levels ✓  
 Korrekte opvul van 1ste en 2de energievlakke.
- Correct filling of 3<sup>rd</sup> energy level ✓  
 Korrekte vul van 3de energievlak

**IF: Not using opposite spins (1↓) when filling electrons: deduct 1 mark**  
**Indien teenoorgestelde spinrigtings nie in orbitale sigbaar is nie: trek 1 punt af.**

3p	1	1	
3s	1↓		
2p	1↓	1↓	1↓
2s	1↓		
1s	1↓		

8.3 (Atomic) orbital/ (Atoom-)orbitaal ✓ (1)

8.4 6 ✓✓ (2)

8.5 1 ✓ (3)  
 Element X/sodium is in group/groep 1(I) **OR/OF**  
 has the atomic number of 11/ het atoomgetal 11 **OR/OF**  
 has 11 protons/ het 11 protone ✓✓

8.6 Na<sub>2</sub>S **OR/OF** X<sub>2</sub>Z ✓✓ (2)

8.7 Relative atomic mass/ Relatiewe atoommassa:  

$$= \frac{(23 \times 78,9) + (24 \times 21,1)}{100} \checkmark$$

$$= 23,21 \text{ (amu)} \checkmark$$
 (3)  
**[17]**

QUESTION/VRAAG 9

9.1 Energy needed per mole to remove an electron(s) from (a neutral) atom in the gaseous phase. ✓✓ (2 or 0)  
*Energie wat per mol benodig word om 'n elektron(e) uit ('n neutrale) atoom in die gasfase te verwyder.* (2)

9.2 B ✓ (1)

9.3 **Explanation based on diagram B/ Verduideliking gebaseer op diagram B**

- B/nitrogen has a smaller atomic radius/ the valence electrons are closer to the nucleus. ✓ /*Stikstof het 'n kleiner atoomradius/ die valenselektrone is nader aan die kern*
- More energy is required to remove (valence) electrons of B/nitrogen. ✓ /*Meer energie is nodig om (valens) elektrone van B/stikstof te verwyder.*

OR/OF

**Explanation based on diagram A/ Verduideliking gebaseer op diagram A**

- A/phosphorus has a larger atomic radius/ the valence electrons further from the nucleus. / *Fosfor het 'n groter atoomradius/ die valenselektrone verder van die kern af.*
- Less energy is required to remove (valence) electrons of A/phosphorus. / *Less energy is required to remove (valence) electrons of A/phosphorus.* (2)

9.4 Group 15/ V ✓ (1)

9.5  $P^{3-}$  /  $A^{3-}$  ✓✓ (2)

9.6 Anion/Anioon ✓  
Electrons were transferred to element A/it gained electrons/  
*Elektrone is na element A oorgedra/dit het elektrone ontvang* ✓. (2)

[10]

**QUESTION/VRAAG 10**

10.1.1 Ionic/Ionies ✓ (1)

10.1.2 Covalent/Kovalent ✓ (1)

10.1.3 Metallic/Metaal(binding) ✓ (1)

10.2.1 B ✓  
(Accept: oxygen, water, H<sub>2</sub>O) / (Aanvaar: suurstof, water, H<sub>2</sub>O) (1)

10.2.2 C ✓  
(Accept: cobalt, Fe<sub>2</sub>(SO<sub>4</sub>)<sub>3</sub>, Iron(III) sulphate)  
(Aanvaar: kobalt, Fe<sub>2</sub>(SO<sub>4</sub>)<sub>3</sub>, yster(III)sulfaat) (1)

10.3.1 The sharing of electrons between atoms ✓ (of non-metals) to form molecules ✓  
Die deel van elektrone tussen atome ✓ (van nie-metale) om molekules te vorm (2)

10.3.2  $\text{H} \times \overset{\circ\circ}{\underset{\circ\circ}{\text{O}}} \times \text{H}$  (Accept angular shape/ Aanvaar hoekige vorm)

✓ Two bonding pair of electrons between H and O  
Twee bindingspaar-elektrone tussen H en O

✓ Two lone pair of electrons on oxygen/  
Twee alleenpaar-elektrone op suurstof

(2)

10.4.1 Iron(III) sulphate / yster(III)sulfaat ✓✓  
**IF:** only iron sulphate (without (III)): Max. 1/2  
**INDIEN:** slegs yster sulfaat (sonder (III)): Maks. 1/2 (2)

10.4.2 Fe – 2 ✓  
S – 3 ✓  
O – 12 ✓ (3)

10.4.3 Cation/Katioon: Fe<sup>3+</sup> ✓  
Anion/Anioon: SO<sub>4</sub><sup>2-</sup> ✓ (2)

**[16]**

**QUESTION 11**

11.1.1 (Change in which) new chemical substances are formed. ✓✓  
 (Verandering waarin) nuwe chemiese stowwe gevorm word

**OR/OF**

Energy changes are much larger than those of physical changes.  
 Energieveranderinge is baie groter as dié van fisiese veranderinge.

**OR/OF**

Mass of atoms are conserved, but the number of molecules is not. / Die massa van atome word bewaar, maar die aantal molekules is nie

(2)

11.1.2 **Any ONE** applicable OBSERVATION. / **Enige EEN** toepaslike WAARNEMING.

- Bubbles ✓ /  
 Bubbles

- Dissolving of magnesium ribbon/powder /  
 Oplosing van magnesiumlint/poeier

- Change in temperature – container getting warm /  
 Verandering in temperatuur – houer word warm

(1)

11.2. Total mass reactants/ *Totale massa van reaktante:*

$$= m[2\text{NH}_3]$$

$$= 2[(14+3(1))] \checkmark = 34 \text{ g}$$

Total mass products/ *Totale massa van produkte:*

$$= m(\text{N}_2) + m(3\text{H}_2)$$

$$= 2(14) + 3(2 \times 1) \checkmark = 34 \text{ g}$$

Total mass reactants = total mass products

*Totale massa van reaktante = totale massa van produkte*

(3)

11.3.1 Physical (change) / *fisiese (verandering)* ✓

(1)

11.3.2 Sublimation / *sublimation*

(1)

11.3.3 Less (energy) / *Less (energy)* ✓

- There are no new substances formed ✓ / *Geen nuwe stowwe vorm nie*

- physical change requires less energy than chemical change / *Fisiese verandering verg minder energie as chemiese verandering/*

- phase change requires less energy than breaking of old bonds and formation of new bonds. / *Faseverandering verg minder energie as die breek van ou bindings en die vorming van nuwe bindings.*

(2)

[10]

**GRAND TOTAL: [150]**