



LIMPOPO

PROVINCIAL GOVERNMENT
REPUBLIC OF SOUTH AFRICA

DEPARTMENT OF
EDUCATION

**NATIONAL
SENIOR CERTIFICATE**

GRADE 12

MATHEMATICS P1

JUNE 2026

Stanmorephysics.com

MARKS: 150

TIME: 3 hours

This question paper consists of 8 pages and 1 information sheet.

INSTRUCTIONS AND INFORMATION

Read the following instructions carefully before answering the questions.

1. This question paper consists of 8 questions.
2. Answer ALL the questions.
3. Number your answers correctly according to the numbering system used in this question paper.
4. Clearly show ALL calculations, diagrams and graphs that you have used in determining your answers.
5. Answers only will NOT necessarily be awarded full marks.
6. An approved scientific calculator (non-programmable and non-graphical) may be used, unless stated otherwise.
7. If necessary, answers should be rounded off to TWO decimal places, unless stated otherwise.
8. Diagrams are NOT necessarily drawn to scale.
9. Information sheet with formulae is included at the end of the question paper.
10. Write neatly and legibly.

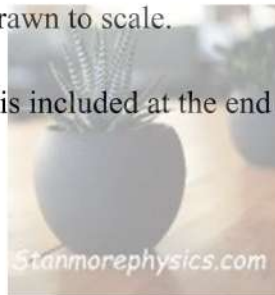

QUESTION 1

1.1 Solve for x :

1.1.1 $x^2 - x = 12$ (3)

1.1.2 $4x^2 - 12x - 6 = 0$ (correct to **TWO** decimal digits) (3)

1.1.3 $2x - \sqrt{x+4} = 7$ (4)

1.1.4 $(3x-2)^2 > 3x$ (4)

1.1.5 $2^{\frac{2x}{3}} + 2^{\frac{x}{3}} - 6 = 0$ (3)

1.2 Solve for x and y simultaneously, where:

$6y = x^2 - 2x - 6$ and $\sum_{n=3}^4 x(n-2)^2 = 10y$ (6)

1.3 Without the use of a calculator, prove that $(x+x^{-1})^2 - (x-x^{-1})^2 = 4$ (4)
[27]

QUESTION 2

Given an arithmetic sequence $x+4 ; 2x ; x+8 ; \dots$

2.1 Calculate the value of x . (2)

2.2 Write down the first three terms of the sequence. (1)

2.3 Calculate the 100th term. (2)

2.4 Determine the term of the sequence which is equal to 48. (3)

2.5 Calculate the sum of the first 21 terms. (2)
[10]

QUESTION 3

3.1 The distance an object travelled (in meters) from a starting point at a particular time (in seconds) is recorded in the table below:

Time in seconds (t)	1	2	3	4	5	6
Distance from starting point (d)	4	10	18			

3.1.1 Complete the table for the next three seconds. (3)

3.1.2 The relationship between the distance (d) travelled by the object in a particular time (t) is modelled by the equation $d = mt^2 + nt$
Determine the values of m and n . (2)

3.1.3 Determine the distance travelled by the object after 10 seconds. (2)

3.2 A rubber ball dropped from a height of 30m loses 20% of its previous height on each rebound.

3.2.1 Calculate the height the ball will reach after the second bounce. (2)

3.2.2 Show that the series converges. (2)

3.2.3 Calculate the sum to infinity. (2)

3.2.4 Determine the number of times the ball will rise to a height of more than 4m. (6)

3.2.5 Calculate the total distance the ball will travel before it comes to rest. (3)

[22]

QUESTION 4

- 4.1 The sketch below shows the hyperbola $g(x) = \frac{1}{x+3} - 1$. The y -intercept of the straight line h is 3 and the line passes through the point of intersection of the asymptotes of g . Line h cuts the x -axis at F and the y -axis at G respectively.

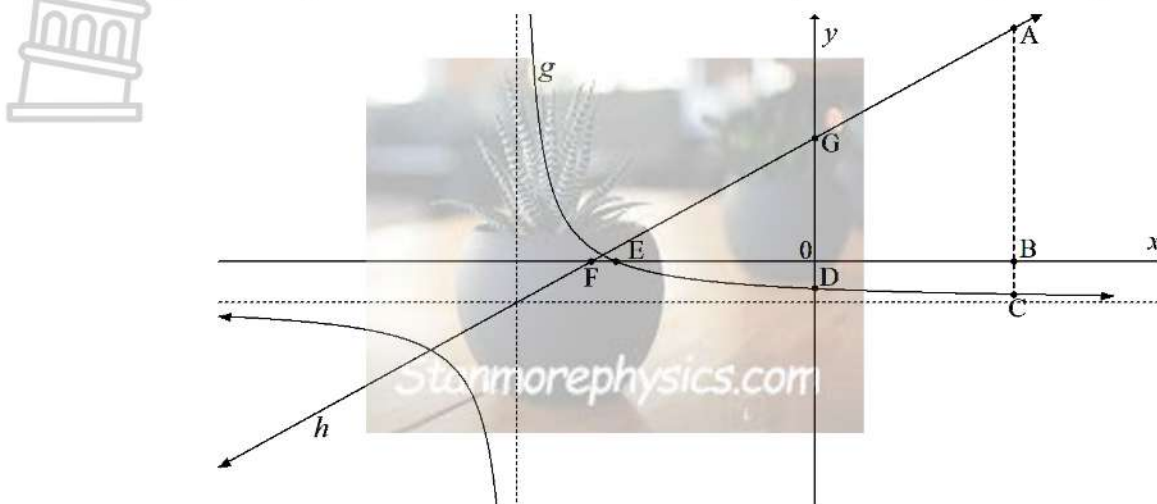

- 4.1.1 Write down the equations of the asymptotes of g . (2)
- 4.1.2 Determine the domain of g . (1)
- 4.1.3 Determine the equation of h . (3)
- 4.1.4 Write down the equation of the **axis of symmetry of g with the negative gradient**. (2)
- 4.1.5 Determine the equations of the asymptotes of $f(x) = g(x-2) + 4$. (2)
- 4.1.6 If $ABC \parallel y$ -axis and $AC = 6\frac{7}{15}$ **units**, **calculate** the length of OB . (4)
- 4.1.7 Calculate the area of $ABOG$. (4)
- 4.2 Given: $f(x) = x^2 - 2x - 3$
- 4.2.1 Calculate the coordinates of the x -intercepts of the graph of f . (2)
- 4.2.2 Calculate the coordinates of the turning point of the graph of f . (2)
- 4.2.3 Draw a sketch graph of f . Indicate the turning point and the intercepts with the axes on the sketch. (4)
- 4.2.4 Write down the equation of the tangent that passes through the turning point of the graph of f . (1)
- 4.2.5 Use the graph of f to determine value(s) for x if $2x^2 - 4x - 6 < 0$. (2)
- [29]**

QUESTION 5

The graph of $f(x) = a\sqrt{x}$, $x \geq 0$ and is sketched below. The point $P(4; 2)$ lies on the graph of f .

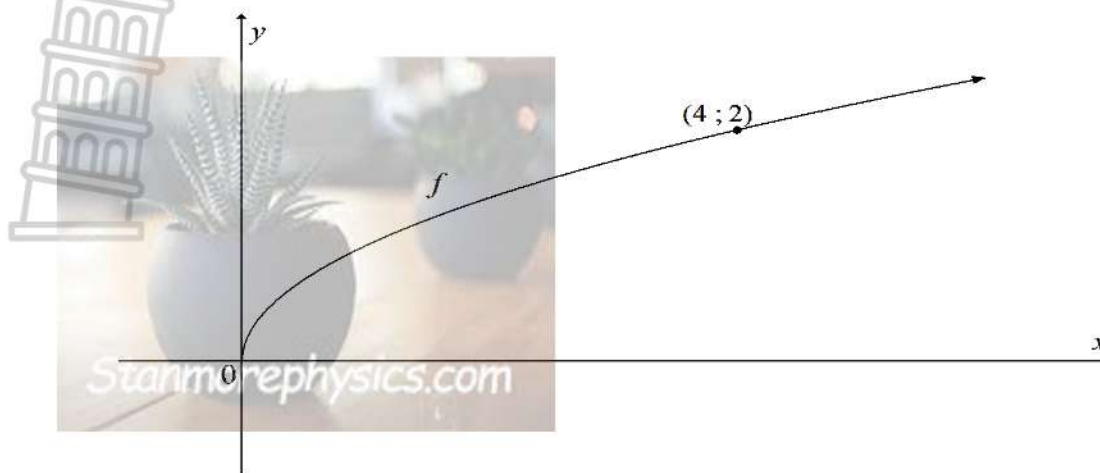

- 5.1 Calculate the value of a . (2)
 - 5.2 Determine the equation of f^{-1} , in the form $y = \dots$. (2)
 - 5.3 Write down the range of f^{-1} . (1)
 - 5.4 Draw the graph of f^{-1} for $x \geq 0$ and clearly indicates the coordinates of the reflecting point. (3)
 - 5.5 The graph of f is reflected across the line $y = x$ and thereafter it is reflected across the x -axis. Determine the equation of the new function in the form $y = \dots$. (3)
- [11]**

QUESTION 6

- 6.1 Given: $f(x) = x - x^2$
 - 6.1.1 Determine $f'(x)$ from first principles. (4)
 - 6.1.2 Hence, calculate $f'(2)$. (1)
 - 6.2 Differentiate the following with respect to x :
 - 6.2.1 $y = \frac{2x^2 - 11x + 15}{3 - x}$ ($x \neq 3$) (3)
 - 6.2.2 $y = (x^2 - \sqrt{x})^2$ (4)
 - 6.3 The equation of a tangent to the curve of $f(x) = ax^3 + bx$ is $y = x + 4$. If the point of contact is $(-1; 3)$, calculate the values of a and b . (6)
- [18]**

QUESTION 7

7.1 Given: $f(x) = x^3 - 6x^2 + 9x - 4$

7.1.1 Show that $(x - 1)$ is a factor of $f(x)$. (2)

7.1.2 Determine the **coordinates** of the x -intercepts of f . (4)

7.1.3 Determine the **coordinates** of the turning points of f . (4)

7.1.4 Draw a neat sketch graph of f indicating the **coordinates** of the turning points as well as the x -intercepts. (4)

7.1.5 Hence, or otherwise, solve: $(x - 2)^3 - 6(x - 2)^2 + 9(x - 2) = 4$ (2)

7.1.6 Determine the coordinates of the point of inflection of $f(x)$. (3)

7.2 The measurements of a rectangular dam are as follows:

length (l) = $60 - 2x$, width (w) = $2x$ and depth (d) = $\frac{x}{2}$.



7.2.1 Determine the volume of the dam in terms of x . (2)

7.2.2 Determine **the** value of x for which the volume of the dam is a maximum. (3)

7.2.3 Calculate the maximum volume of the dam. (2)

[26]

QUESTION 8

Just after birth the **weight** of a baby drops for a few days and then starts to increase again.

The average **weight** of a baby in its first 30 days of life can be approximated by the following equation:

$$m(t) = 0,02t^3 - 0,2t^2 + 3200, \quad 0 \leq t \leq 30$$

where t is the time in days and $m(t)$ is the **weight** in grams.

8.1 Calculate the **weight** of the baby at birth. (1)

8.2 Calculate on what day the **weight** reaches a minimum. (4)

8.3 Calculate the maximum **weight** of the baby in the 30-day period. (2)

[7]

TOTAL: 150



INFORMATION SHEET

$$x = \frac{-b \pm \sqrt{b^2 - 4ac}}{2a}$$

$$A = P(1 + ni)$$

$$A = P(1 - ni)$$

$$A = P(1 - i)^n$$

$$A = P(1 + i)^n$$

$$T_n = a + (n - 1)d$$

$$S_n = \frac{n}{2} [2a + (n - 1)d]$$

$$T_n = ar^{n-1}$$

$$S_n = \frac{a(r^n - 1)}{r - 1}; \quad r \neq 1$$

$$S_\infty = \frac{a}{1 - r}; \quad -1 < r < 1$$

$$F = \frac{x[(1 + i)^n - 1]}{i}$$

$$P = \frac{x[1 - (1 + i)^{-n}]}{i}$$

$$f'(x) = \lim_{h \rightarrow 0} \frac{f(x + h) - f(x)}{h}$$

$$d = \sqrt{(x_2 - x_1)^2 + (y_2 - y_1)^2}$$

$$M\left(\frac{x_1 + x_2}{2}, \frac{y_1 + y_2}{2}\right)$$

$$y = mx + c$$

$$y - y_1 = m(x - x_1)$$

$$m = \frac{y_2 - y_1}{x_2 - x_1}$$

$$m = \tan \theta$$

$$(x - a)^2 + (y - b)^2 = r^2$$

In ΔABC :

$$\frac{a}{\sin A} = \frac{b}{\sin B} = \frac{c}{\sin C}$$

$$a^2 = b^2 + c^2 - 2bc \cos A$$

$$\text{area } \Delta ABC = \frac{1}{2} ab \sin C$$

$$\sin(\alpha + \beta) = \sin \alpha \cos \beta + \cos \alpha \sin \beta$$

$$\sin(\alpha - \beta) = \sin \alpha \cos \beta - \cos \alpha \sin \beta$$

$$\cos(\alpha + \beta) = \cos \alpha \cos \beta - \sin \alpha \sin \beta$$

$$\cos(\alpha - \beta) = \cos \alpha \cos \beta + \sin \alpha \sin \beta$$

$$\cos 2\alpha = \begin{cases} \cos^2 \alpha - \sin^2 \alpha \\ 1 - 2\sin^2 \alpha \\ 2\cos^2 \alpha - 1 \end{cases}$$

$$\sin 2\alpha = 2\sin \alpha \cos \alpha$$

$$\bar{x} = \frac{\sum fx}{n}$$

$$\sigma^2 = \frac{\sum_{i=1}^n (x_i - \bar{x})^2}{n}$$

$$P(A) = \frac{n(A)}{n(S)}$$

$$P(A \text{ or } B) = P(A) + P(B) - P(A \text{ and } B)$$

$$y = a + bx$$

$$b = \frac{\sum (x - \bar{x})(y - \bar{y})}{\sum (x - \bar{x})^2}$$

 LIMPOPO PROVINCIAL GOVERNMENT REPUBLIC OF SOUTH AFRICA <hr/> DEPARTMENT OF EDUCATION	NSC Answer Book <i>NSS-antwoordboek</i>
---	---

National Senior Certificate/*Nasionale Senior Sertifikaat* (Grade 12/*Graad 12*) JUNE/*JUNIE* 2026

CENTRE NAME/ <i>SENTRUM NAAM</i>	
-------------------------------------	--

CANDIDATE NAME/ <i>KANDIDAAT NAAM</i>	
--	--

DATE/ <i>DATUM</i>	
--------------------	--

SUBJECT/ <i>VAK</i>	MATHEMATICS/ <i>WISKUNDE</i>	PAPER/ <i>VRAESTEL</i>	1
---------------------	------------------------------	------------------------	---



MATHEMATICS/*WISKUNDE*

MODERATOR'S INITIALS IN RELEVANT BLOCK											
Educator			Dept Head				Subj Advisor			Prov Mod	
Question	Marks		DH	Marks		SA	Marks		PM	Marks	
1											
2											
3											
4											
5											
6											
7											
8											
TOTAL											

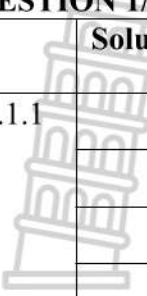

This answer book consists of 21 pages/*Hierdie antwoordboek bestaan uit 21 bladsye*

PLEASE FOLLOW THESE INSTRUCTIONS CAREFULLY	VOLG ASSEBLIEF HIERDIE INSTRUKSIES NOUKEURIG
<ol style="list-style-type: none">1. Clearly write your Name and School in the space provided and attach your barcode label in the space provided.2. Answer ALL questions in the spaces provided.3. No pages may be torn from this answer book.4. Read the instructions printed on your timetable carefully as well as any other instructions which may be given in each examination paper.5. Candidates may not retain an answer book or remove it from the examination room.6. Answers must be written in black/blue ink as distinctly as possible. Do not write in the margins.7. Write the numbers of the questions you have answered on the front cover of the answer book where marks are to be recorded.8. If you require additional space for your answers:<ul style="list-style-type: none">- Use the additional space provided at the end of the answer book.- When answering a question in the additional space, indicate clearly the question number in the column on the LHS.- Rule off after each answer.9. Draw a neat line through any work/rough work that must not be marked.	<ol style="list-style-type: none">1. Skryf jou naam en skool in die ruimtes soos verskaf en plak jou stafieskodeplakker in die ruimte soos verskaf.2. Beantwoord ALLE vrae in die ruimtes wat voorsien is.3. Geen bladsye mag uit hierdie antwoordeboek geskeur word nie.4. Lees die instruksies wat op jou eksamenrooster gedruk is, sorgvuldig deur, asook enige ander instruksies wat op elke eksamenvraestel gegee word.5. Geen antwoordeboek mag deur die kandidaat behou of uit die eksamenlokaal verwyder word nie.6. Skryf die antwoorde so duidelik moontlik met swart/blou ink. Laat die kantlyne oop.7. Skryf die nommers van die vrae wat jy beantwoord het op die voorblad van die antwoordeboek waar die punte aangebring word.8. In geval jy addisionele ruimte benodig vir jou antwoorde:<ul style="list-style-type: none">- Gebruik die addisionele ruimte wat aan die einde van die antwoordeboek voorsien word.- As 'n vraag in die addisionele ruimte beantwoord word, dui duidelik die vraagnommer in die kolom aan die LK aan.- Trek 'n lyn na elke antwoord.9. Trek 'n netjiese lyn deur enige werk/rofwerk wat nie nagesien moet word nie.

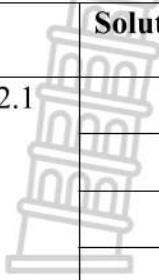

QUESTION 1/VRAAG 1

	Solutions / Oplossing	Marks Punte
1.1.1		(3)
1.1.2	 Stanmorephysics.com	(3)
1.1.3	 Stanmorephysics.com	(4)
1.1.4		

QUESTION 2/VRAAG 2

	Solutions / Oplossing	Marks Punte
2.1		(2)
2.2		(1)
2.3		(2)
2.4	 Stanmorephysics.com	(3)
2.5		(2)
		[10]

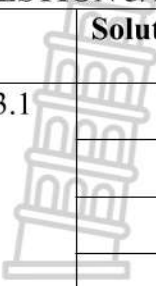

QUESTION 3/VRAAG 3



	Solutions / Oplossing	Marks Punte
3.1		(3)
3.1.2	 Stanmorephysics.com	(2)
3.1.3		(2)
3.2.1		

		(3)
3.2.2		(2)
3.2.3		(2)
3.2.4		(6)
3.2.5		(2)
		[22]

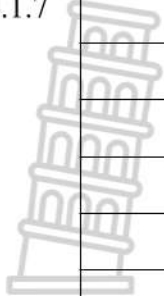
QUESTION 4/VRAAG 4

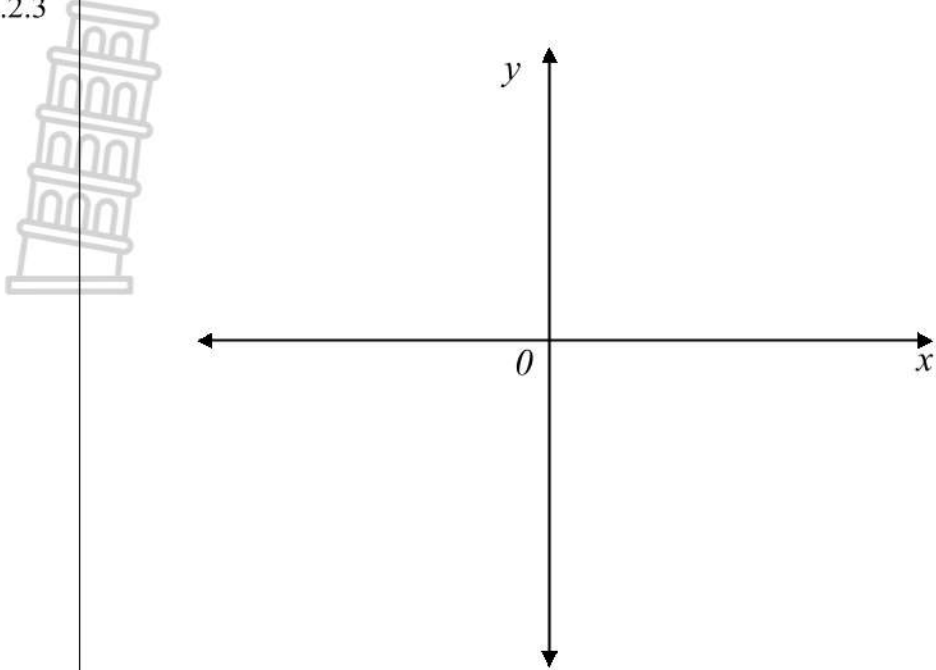

Solutions / Oplossing		Marks Punte
4.1.1		(2)
4.1.2		
4.1.3		(4)
4.1.4		(3)
4.1.5		(2)
4.1.6		(2)

4.1.7		(4)
4.2.1	 Stanmorephysics.com	(2)
4.2.2		(2)

4.2.3		(4)
4.2.4		(1)
4.2.5		(2)
		[29]

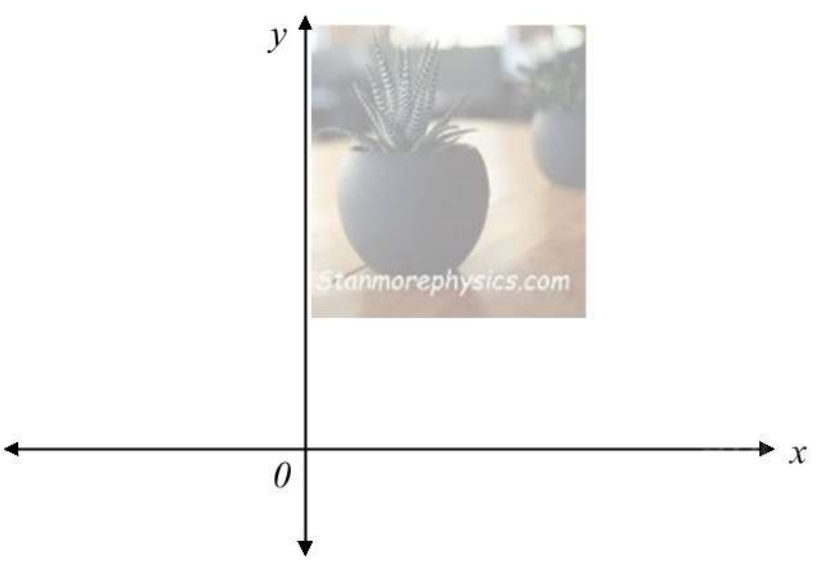
QUESTION 5/VRAAG 5

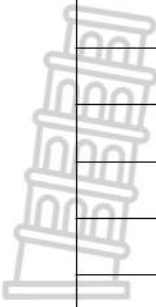
Solutions / Oplossing		Marks Punte
5.1		(2)
5.2		(2)
5.3		(1)
5.4		(3)
5.5		(3)
		[11]

		(4)
6.2.3	 Stanmorephysics.com	(6)
		[18]

QUESTION 7/VRAAG 7

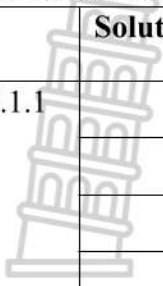

Solutions / Oplossing	Marks Punte
7.1.1	(2)
7.1.2	(4)
7.1.3	(4)

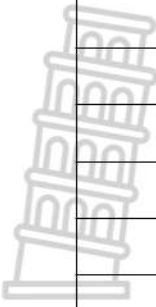

		
		(3)
7.2.3		
		(2)
		[26]



QUESTION 8/VRAAG 8

Solutions / Oplossing		Marks Punte
8.1		(1)
8.2		(4)
8.3		(2)
		[7]

Additional space / Bykomende ruimte	Marks Punte
	



Additional space / <i>Bykomende ruimte</i>	Marks Punte
	



Additional space / <i>Bykomende ruimte</i>	Marks Punte
	





LIMPOPO

PROVINCIAL GOVERNMENT
REPUBLIC OF SOUTH AFRICA

DEPARTMENT OF
EDUCATION

**NATIONAL SENIOR CERTIFICATE /
NASIONALE SENIOR SERTIFIKAAT**

GRADE/GRADE 12

MATHEMATICS P1/WISKUNDE V1
© Stanmorephysics.com
MARKING GUIDELINES/NASIENRIGLYNE
JUNE/JUNIE 2026

Stanmorephysics.com

MARKS/PUNTE: 150



This marking guidelines consists of 17 pages/ Hierdie nasienriglyne bestaan uit 17 bladsye

NOTE/NOTA:

- If a candidate answers a question TWICE, only mark the FIRST attempt/ *As 'n kandidaat 'n vraag TWEE keer beantwoord, merk slegs die EERSTE poging*
- Consistent accuracy applies in ALL aspects of the marking guidelines/ *Konsekwente akkuraatheid is van toepassing in ALLE aspekte van die nasienriglyne*

QUESTION 1/VRAAG 1

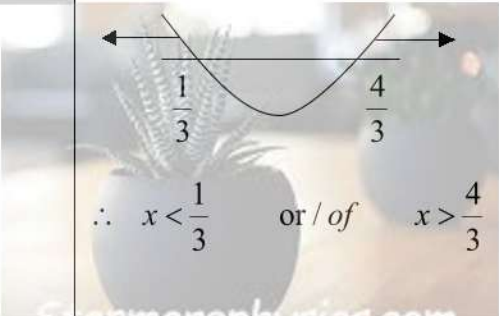
1.1	1.1.1	$x^2 - x = 12$ $x^2 - x - 12 = 0$ $(x - 4)(x + 3) = 0$ $x = 4$ or / of $x = -3$	✓ standard form/ <i>standaardvorm</i> ✓ $x = 4$ ✓ $x = -3$	(3)
	1.1.2	$4x^2 - 12x - 6 = 0$ $x = \frac{-(-12) \pm \sqrt{(-12)^2 - 4(4)(-6)}}{2(4)}$ $x = \frac{12 \pm \sqrt{240}}{8}$ $x = -0,44$ or / of $x = 3,44$	✓ substitution/ <i>vervanging</i> ✓ answer/ <i>antwoord</i> ✓ answer/ <i>antwoord</i>	(3)
	1.1.3	$2x - \sqrt{x+4} = 7$ $2x - 7 = \sqrt{x+4}$ $(2x - 7)^2 = (\sqrt{x+4})^2$ $4x^2 - 28x + 49 = x + 4$ $4x^2 - 29x + 45 = 0$ $(4x - 9)(x - 5) = 0$ $x \neq \frac{9}{4}$ or / of $x = 5$	✓ isolating the surd/ <i>isoleer wortel</i> ✓ squaring both sides/ <i>kwadreer albei kante</i> ✓ standard form/ <i>standaardvorm</i> ✓ answer with selection/ <i>antwoord met seleksie</i>	(4)

	<p>1.1.4 $(3x-2)^2 > 3x$ $9x^2 - 12x + 4 > 3x$ $9x^2 - 15x + 4 > 0$ $(3x-4)(3x-1) > 0$ CV $x = \frac{4}{3}$ or / of $x = \frac{1}{3}$</p>  <p>$\therefore x < \frac{1}{3}$ or / of $x > \frac{4}{3}$</p>	<p>✓ standard form/<i>standaardvorm</i> ✓ critical values/<i>kritieke waardes</i> ✓✓ answer/<i>antwoord</i> (4)</p>
	<p>1.1.5 $\frac{2x}{2^{\frac{x}{3}}} + 2^{\frac{x}{3}} - 6 = 0$ $\left(2^{\frac{x}{3}}\right)^2 + 2^{\frac{x}{3}} - 6 = 0$ let / <i>stel</i> $2^{\frac{x}{3}} = k$ $k^2 + k - 6 = 0$ $(k-2)(k+3) = 0$ $k = 2$ or / of $k = -3$ $2^{\frac{x}{3}} = 2$ or / of $2^{\frac{x}{3}} = -3$ $\frac{x}{3} = 1$ N/A $x = 3$</p> 	<p>✓ substitution/<i>vervanging</i> ✓ both equations/<i>beide vergelykings</i> ✓ answer/<i>antwoord</i> (3)</p>

<p>1.2</p>	$6y = x^2 - 2x - 6 \quad \dots\dots\dots (1)$ $\sum_{n=3}^4 x(n-2)^2 = 10y \quad \dots\dots\dots (2)$ <p>from (2): $x(3-2)^2 + x(4-2)^2 = 10y$ $x + 4x = 10y$ $5x = 10y$ $x = 2y$</p> $6y = (2y)^2 - 2(2y) - 6$ $4y^2 - 10y - 6 = 0$ $2y^2 - 5y - 3 = 0$ $(2y+1)(y-3) = 0$ $y = -\frac{1}{2} \quad \text{or / of} \quad y = 3$ $x = -1 \quad \text{or / of} \quad x = 6$	<p>✓ expansion/uitbreiding</p> <p>✓ simplification/vereenvoudig</p> <p>✓ substitution/vervanging</p> <p>✓ standard form/standaardvorm</p> <p>✓ both y values/ beide y waardes</p> <p>✓ both x values/ beide x waardes (6)</p>
	<p style="text-align: center;">OR/OF</p> $6y = x^2 - 2x - 6 \quad \dots\dots\dots (1)$ $\sum_{n=3}^4 x(n-2)^2 = 10y \quad \dots\dots\dots (2)$ <p>from (2): $x(3-2)^2 + x(4-2)^2 = 10y$ $x + 4x = 10y$ $5x = 10y$ $y = \frac{x}{2}$</p> $6\left(\frac{x}{2}\right) = x^2 - 2x - 6$ $x^2 - 2x - 6 = 3x$ $x^2 - 5x - 6 = 0$ $(x+1)(x-6) = 0$ $x = -1 \quad \text{or / of} \quad x = 6$ $y = \frac{1}{2} \quad \text{or / of} \quad y = 3$	<p style="text-align: center;">OR/OF</p> <p>✓ expansion/uitbreiding</p> <p>✓ simplification/vereenvoudig</p> <p>✓ substitution/vervanging</p> <p>✓ standard form/standaardvorm</p> <p>✓ both x values/ beide x waardes</p> <p>✓ both y values/beide y waardes (6)</p>

<p>1.3</p>	$(x+x^{-1})^2 - (x-x^{-1})^2 = 4$ <p>LHS: $(x+x^{-1})^2 - (x-x^{-1})^2$</p> $= \left(x + \frac{1}{x}\right)^2 - \left(x - \frac{1}{x}\right)^2$ $= \left(\frac{x^2+1}{x}\right)^2 - \left(\frac{x^2-1}{x}\right)^2$ $= \frac{(x^4+2x^2+1) - (x^4-2x^2+1)}{x^2}$ $= \frac{4x^2}{x^2}$ <p>\therefore LHS = RHS</p>	<p>✓ changing to fractions/<i>verander na breuk</i></p> <p>✓ simplification/<i>vereenvoudig</i></p> <p>✓ simplification/<i>vereenvoudig</i></p> <p>✓ simplification/<i>vereenvoudig</i> (4)</p>
		<p>[27]</p>



QUESTION/VRAAG 2

2.1	$2x - (x + 4) = x + 8 - 2x$ $2x - x - 4 = 8 - x$ $2x = 12$ $x = 6$	✓ common difference/ <i>konstante verskil</i> ✓ answer/ <i>antwoord</i> (2)
2.2	10 ; 12 ; 14;.....	✓ answer/ <i>antwoord</i> (1)
2.3	$T_{100} = 10 + 99(2)$ $= 208$	✓ substitution/ <i>vervanging</i> ✓ answer/ <i>antwoord</i> (2)
2.4	$a + (n - 1)d = 48$ $10 + 2(n - 1) = 48$ $2n + 8 = 48$ $2n = 40$ $n = 20$	✓ $T_n = 48$ ✓ substitution/ <i>vervanging</i> ✓ answer/ <i>antwoord</i> (3)
2.5	$S_{21} = \frac{21}{2} [2(10) - (21 - 1)(2)]$ $= 630$	✓ substitution/ <i>vervanging</i> ✓ answer/ <i>antwoord</i> (2)
		[10]

	<p>3.2.4 24 ; 19,2 ;.....</p> $r = \frac{19,2}{24}$ $r = \frac{4}{5}$ $T_n = 24 \left(\frac{4}{5}\right)^{n-1}$ $T_n > 4$ $24 \left(\frac{4}{5}\right)^{n-1} > 4$ $\left(\frac{4}{5}\right)^{n-1} > \frac{1}{6}$ $(n-1) \log\left(\frac{4}{5}\right) > \log\left(\frac{1}{6}\right)$ $n-1 < 8,0296.....$ $n < 9,0296.....$ <p>9 times / keer</p>	<p>✓ 24</p> <p>✓ value of r/waarde van r</p> <p>✓ $T_n > 4$</p> <p>✓ $\left(\frac{4}{5}\right)^{n-1} > \frac{1}{6}$</p> <p>✓ use of logs/gebruik van logs</p> <p>✓ answer/antwoord (6)</p>
	<p>3.2.5 Total distance / Totale afstand</p> $= 30 + (120 \times 2)$ $= 270 \text{ m}$ <p style="text-align: center;">OR/OF</p> <p>Total Distance / Totale afstand</p> $= \frac{24 \times 2}{1 - \frac{4}{5}} + 30$ $= 270 \text{ m}$	<p>✓ $30 + (120 \times 2)$</p> <p>✓ (120×2)</p> <p>✓ answer/antwoord (3)</p> <p style="text-align: center;">OR/OF</p> <p>✓ 24×2</p> <p>✓ $\frac{24 \times 2}{1 - \frac{4}{5}} + 30$</p> <p>✓ answer/antwoord (3)</p>
		<p>[22]</p>

QUESTION/VRAAG 4

4.1	4.1.1 $x = -3$ and / en $y = -1$	✓ answer/antwoord ✓ answer/antwoord (2)
	4.1.2 $x \in R, x \neq -3$	✓ answer/antwoord (1)
	4.1.3 $m = \frac{3 - (-1)}{0 - (-3)}$ $m = \frac{4}{3}$ $h(x) = \frac{4}{3}x + 3$	✓ substitution/vervanging (0 ; 3) and/en (-3 ; -1) ✓ gradient/gradiënt ✓ equation/vergelyking (3)
	4.1.4 $y = -(x+3) - 1$ $y = -x - 4$ OR/OF $y = -x + c$ $-1 = -(-3) + c$ $c = -4$ $y = -x - 4$	✓ substitution/vervanging ✓ answer/antwoord (2) OR/OF ✓ substitution/vervanging ✓ answer/antwoord (2)
	4.1.5 By translation/Deur translasie 2 units to the right and 4 units up/2 eenhede regs en 4 eenhede op $x = -1$ and / en $y = 3$ OR/OF $g(x-2) + 4 = \frac{1}{x+1} + 3$ $x = -1$ and / en $y = 3$	✓ $x = -1$ ✓ $y = 3$ (2) OR/OF ✓ $x = -1$ ✓ $y = 3$ (2)

	4.1.6	$AC = 6\frac{7}{15} = \frac{97}{15}$ $AC = f(x) - g(x)$ $\frac{97}{15} = \frac{4}{3}x + 3 - \left(\frac{1}{x+3} - 1\right)$ $\frac{97}{15} = \frac{4x+9}{3} - \left(\frac{-x-2}{x+3}\right)$ $\frac{97}{15} = \frac{4x+9}{3} + \frac{x+2}{x+3}$ $60x^2 + 69x - 378 = 0$ $20x^2 + 23x - 126 = 0$ $(20x + 63)(x - 2) = 0$ $x \neq \frac{63}{20} \quad \text{or / of} \quad x = 2$	✓ equation/vergelyking ✓ simplification/vereenvoudig ✓ standard form /standaardvorm ✓ answer with selection/ antwoord met seleksie (4)
	4.1.7	$y = \frac{4}{3}x + 3$ $y = \frac{4}{3}(2) + 3$ $y = \frac{17}{3}$ $AB = \frac{17}{3}$ <p>Area of ABOG / Opv ABOG</p> $= \frac{1}{2}(OG)(AB)(OB)$ $= \frac{1}{2}(3)\left(\frac{17}{3}\right)(2)$ $= 17$	✓ substitution/vervanging ✓ answer/antwoord ✓ substitution/vervanging ✓ answer/antwoord (4)
4.2	4.2.1	$x^2 - 2x - 3 = 0$ $(x+1)(x-3) = 0$ $x = -1 \quad \text{or / of} \quad x = 3$	✓ $y = 0$ ✓ both values of x /albei waardes van x (2)

QUESTION/VRAAG 5

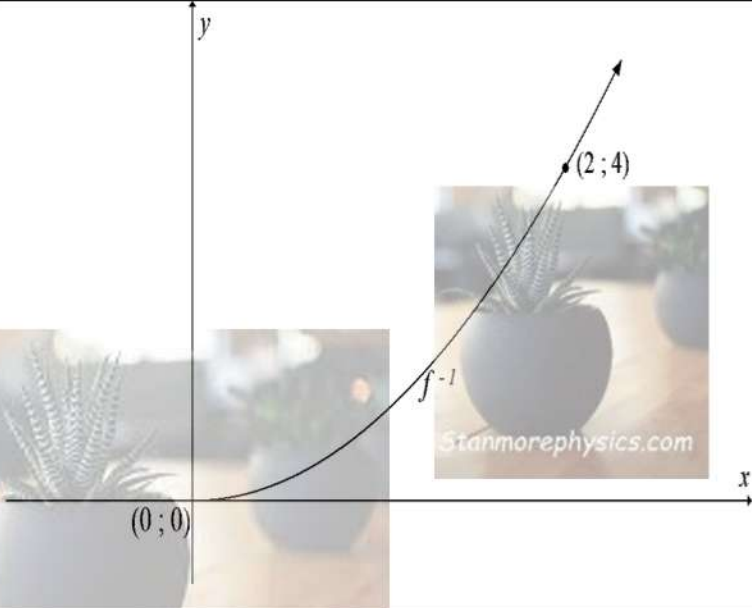
5.1	$y = a\sqrt{x}$ $2 = a\sqrt{4}$ $a = 1$ $y = \sqrt{x}$	✓ substitution/ <i>vervang</i> ✓ answer/ <i>antwoord</i> (2)
5.2	$y = \sqrt{x}$ $x = \sqrt{y}$ $f^{-1}(x) = x^2 ; x \geq 0$	✓ interchange x and y / <i>ruil x en y</i> ✓ inverse (2)
5.3	$y \geq 0$	✓ answer/ <i>antwoord</i> (1)
5.4		✓ shape/ <i>vorm</i> f^{-1} ✓ (0;0) ✓ the coordinates of f^{-1} / <i>die koördinate van f^{-1}</i> (3)
5.5	Reflecting f across the line $y = x$ is the inverse of f , i.e. f^{-1} / <i>Reflekteer f oor die lyn $y = x$ is die inverse van f, d.i. f^{-1}</i> $f(x) = \sqrt{x}$ $f^{-1}(x) = x^2$ $y = -x^2; \quad x \geq 0$	✓ $f^{-1}(x) = x^2$ ✓ $y = -x^2$ ✓ restriction/ <i>beperking</i> (3)
		[11]

QUESTION/VRAAG 6

6.1	6.1.1	$f(x) = x - x^2$ $f'(x) = \lim_{h \rightarrow 0} \frac{f(x+h) - f(x)}{h}$ $= \lim_{h \rightarrow 0} \frac{(x+h) - (x+h)^2 - (x - x^2)}{h}$ $= \lim_{h \rightarrow 0} \frac{x+h - x^2 - 2xh - h^2 - x + x^2}{h}$ $= \lim_{h \rightarrow 0} \frac{h - 2xh - h^2}{h}$ $= \lim_{h \rightarrow 0} \frac{h(1 - 2x - h)}{h}$ $= \lim_{h \rightarrow 0} (1 - 2x - h)$ $= 1 - 2x$	<p>✓ expansion/uitbreiding</p> <p>✓ simplification/vereenvoudig</p> <p>✓ common factor/gemeenskaplike faktor</p> <p>✓ answer/antwoord (4)</p>
	6.1.2	$f'(2) = 1 - 2(2)$ $= -3$	<p>✓ answer/antwoord (1)</p>
6.2	6.2.1	$y = \frac{2x^2 - 11x + 15}{3 - x}$ $= \frac{(2x - 5)(x - 3)}{-(x - 3)}$ $= -2x + 5$ $\frac{dy}{dx} = -2$	<p>✓ factorization/faktorisering</p> <p>✓ simplification/vereenvoudig</p> <p>✓ answer/antwoord (3)</p>
	6.2.2	$y = (x^2 - \sqrt{x})^2$ $y = (x^2 - \sqrt{x})(x^2 - \sqrt{x})$ $y = \left(x^2 - x^{\frac{1}{2}}\right) \left(x^2 - x^{\frac{1}{2}}\right)$ $y = x^4 - 2x^{\frac{5}{2}} + x$ $\frac{dy}{dx} = 4x^3 - 5x^{\frac{3}{2}} + 1$	<p>✓ product/produk</p> <p>✓ derivative/afgeleide</p> <p>✓ derivative/afgeleide</p> <p>✓ derivative/afgeleide (4)</p>

QUESTION/VRAAG 7

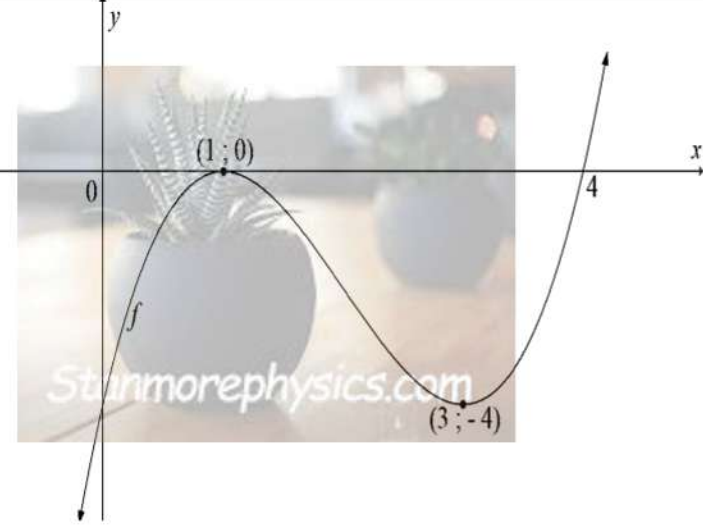
7.1	7.1.1	$f(x) = x^3 - 6x^2 + 9x - 4$ $f(x) = (1)^3 - 6(1)^2 + 9(1) - 4$ $= 0$ <p>$(x-1)$ is a factor of/is 'n faktor van $f(x)$</p>	✓ substitution/vervanging ✓ answer/antwoord (2)
	7.1.2	$\begin{array}{r} 1 \overline{) 1 \quad -6 \quad 9 \quad -4} \\ \underline{ } \\ 1 \quad -5 \quad 4 \quad 0 \end{array}$ $f(x) = (x-1)(x^2 - 5x + 4)$ $(x-1)(x-1)(x-4) = 0$ $x=1 \quad \text{or / of} \quad x=1 \quad \text{or / of} \quad x=4$ $(1; 0) \qquad \qquad (1; 0) \qquad \qquad (4; 0)$	✓ $f(x) = (x-1)(x^2 - 5x + 4)$ ✓ answer/antwoord ✓ answer/antwoord ✓ answer/antwoord (4)
	7.1.3	$(1; 0) \text{ TP/DP}$ $f'(x) = 3x^2 - 12x + 9$ $3x^2 - 12x + 9 = 0$ $x^2 - 4x + 3 = 0$ $(x-1)(x-3) = 0$ $x=1 \quad \text{or / of} \quad x=3$ $y=0 \quad \text{or / of} \quad y=-4$ $(1; 0) \qquad \qquad (3; -4)$ 	✓ derivative/afgeleide ✓ $f'(x) = 0$ ✓ both x values/beide x waardes ✓ both y values/beide y waardes (4)
	7.1.4		✓ shape/vorm ✓ y - intercept/ y - afsnit ✓ x - intercepts/ x - afsnit ✓ turning points/draaipunte (4)

	7.1.5	$(x-2)^3 - 6(x-2)^2 + 9(x-2) = 4$ $x-2 = 1$ $x = 3$ $x-2 = 4$ $x = 6$	✓ answer/antwoord ✓ answer/antwoord (2)
	7.1.6	$6x - 12 = 0$ $6x = 12$ $x = 2$ $f(2) = (2)^3 - 6(2)^2 + 9(2) - 4$ $= -2$ $(2; -2)$	✓ 2 nd derivative/2 ^{de} afgeleide = 0 ✓ value of x/waarde van x ✓ value of y/waarde van y (3)
7.2	7.2.1	$V(x) = (60 - 2x)(2x)\left(\frac{x}{2}\right)$ $= 60x^2 - 2x^3$ 	✓ substitution/vervanging ✓ answer/antwoord (2)
	7.2.2	Max / Maks : $V'(x) = 0$ $120x - 6x^2 = 0$ $20x - x^2 = 0$ $x(20 - x) = 0$ $x \neq 0$ or / of $x = 20$	✓ equating to 0/gelykstel 0 ✓ derivative/afgeleide ✓ answer with selection/antwoord met seleksie (3)
	7.2.3	Max / Maks : $V(x) = 60(20)^2 - 2(20)^3$ $= 8000$	✓ substitution/vervanging ✓ answer/antwoord (2)
			[26]

QUESTION/VRAAG 8

8.1	$m(t) = 0,02t^3 - 0,2t^2 + 3200$ $m(0) = 0,02(0)^3 - 0,2(0)^2 + 3200$ $= 3200\text{g}$ (or 3.2kg)	✓ answer/antwoord (1)
8.2	$m'(t) = 0,06t^2 - 0,2t$ For maximum weight / Vir maks gewig : $m'(t) = 0$ $0,06t^2 - 0,2t = 0$ $t(0,06t - 0,2) = 0$ $t \neq 0$ or / of $0,06t = 0,2$ $t = 6,6666\dots\dots$ $t = 6,67$ On the 7th day / Op die 7de dag	✓ derivative/afgeleide ✓ $m'(t) = 0$ ✓ both values of t /albei waardes van t ✓ answer/antwoord (4)
8.3	Weight / gewig = $m(30)$ $m(30) = 0,02(30)^3 - 0,2(30)^2 + 3200$ $= 3250\text{g}$ (or 3,56kg)	✓ substitution/vervanging ✓ answer/antwoord (2)
		[7]

