



DEPARTMENT OF
EDUCATION

**NATIONAL
SENIOR CERTIFICATE**

GRADE 10

PHYSICAL SCIENCES

PAPER 1

JUNE EXAMINATION

Stanmorephysics.com 2026 *anmorephysics.com*

MARKS: 100

TIME: 2 HOURS

This question paper consists of 10 pages including 1 datasheet

INSTRUCTIONS AND INFORMATION

1. Write your NAME, SUBJECT, GRADE AND DATE on the ANSWER BOOK.
2. This question paper consists of SEVEN questions. Answer ALL the questions in the ANSWER BOOK.
3. Start EACH question on a NEW page in the ANSWER BOOK.
4. Number the answers correctly according to the numbering system used in this question paper.
5. Leave ONE line between two sub questions, for example between QUESTION 2.1 and QUESTION 2.2.
6. You may use a non-programmable calculator.
7. You are advised to use the attached DATA SHEETS.
8. Show ALL formulae and substitutions in ALL calculations.
9. Round off your final numerical answers to a minimum of TWO decimal places.
10. Give brief motivations, discussions, et cetera where required.
11. Write neatly and legibly.



QUESTION 1: Multiple Choice questions

Four options are given as possible answers to the following questions. Choose the answer and write down only the letter (A – D) next to the question number (1.1 – 1.8), for example, 1.9 D.

1.1 In which ONE of the following do sound waves travels the fastest.

- A. Vacuum
 - B. Water
 - C. Solid diamond
 - D. Air
- (2)

1.2 The definition of a *period* is....

- A. time taken to complete one oscillation.
 - B. time taken to move from crest to trough
 - C. distance between two consecutive points in phase.
 - D. number of waves that passes a point in one second.
- (2)

1.3 The diagram below shows a wave that takes **M** seconds to travel from point **P** to point **Q**.

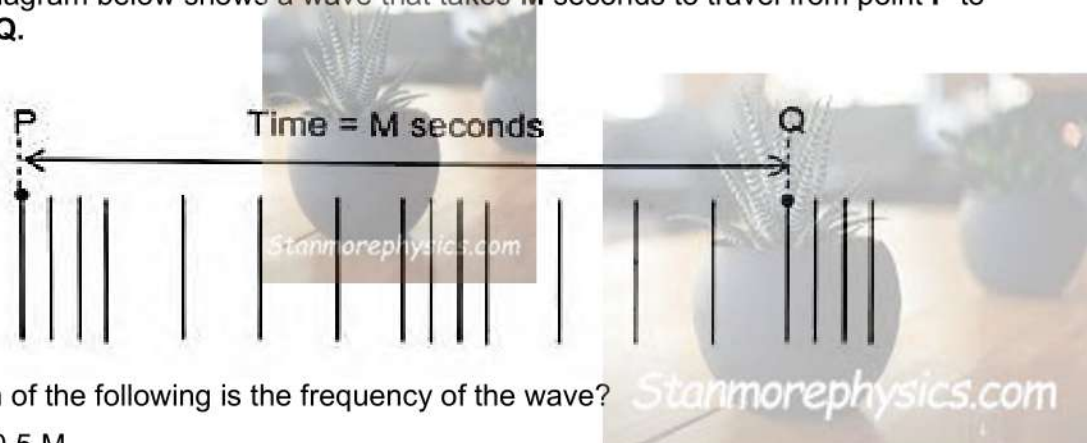

Which of the following is the frequency of the wave?

- A. 0,5 M
 - B. M Hz
 - C. $\frac{2}{M}$ Hz
 - D. $\frac{1}{M}$ Hz
- (2)

1.4 Ultraviolet light can be used:

- A. to scan human bones.
 - B. to clean the equipment in the laboratory.
 - C. in a TV remote.
 - D. in Wi-Fi.
- (2)

- 1.5 A rubber balloon obtains a negative charge after it has been rubbed against human hair.
 Which one of the statements below best explains why this happens?
- A. Negative charges are transferred from the rubber balloon to the human hair.
 - B. Positive charges are transferred from the rubber balloon to the human hair.
 - C. Positive charges are transferred from hair to the rubber balloon.
 - D. Negative charges are transferred from human hair to the rubber balloon.

(2)

- 1.6 Which ONE of the following will result in an object becoming positively charged?
- A. Gains electrons.
 - B. Loses electrons.
 - C. Gains protons.
 - D. Loses protons.

(2)

- 1.7 Two identical light bulbs are connected in parallel, as shown in the circuit diagram below. Voltmeters V_1 and V_2 are connected across each light bulb.

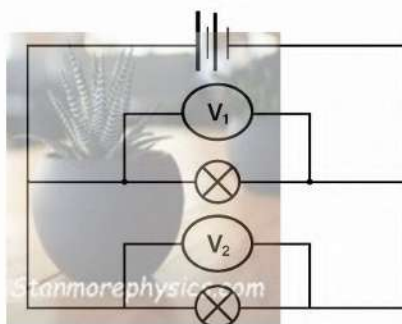

Which one of the following mathematical statements correctly describes the relationship between the readings on voltmeters V_1 and V_2 ?

- A. $V_1 = 2V_2$
- B. $V_1 = \frac{1}{2}V_2$
- C. $V_1 = 4V_2$
- D. $V_1 = V_2$

(2)

1.8 Which ONE of the quantities below is the CORRECT unit of measurement given.

	QUANTITY	UNIT
A	Current	C. s^{-1}
B	Energy	kW
C	Potential difference	$V.s^{-1}$
D	Resistance	V.s

(2)

[16]

QUESTION 2 (Start on a new page)

Two girls stand at opposite ends of the rope; each makes a pulse of the **SAME SPEED**. Pulse **A** with amplitude of 6 cm moves to the right and pulse **B** with the amplitude which is **FOUR TIMES** the amplitude of pulse A moves to the left. The two pulses meet at point **C**.

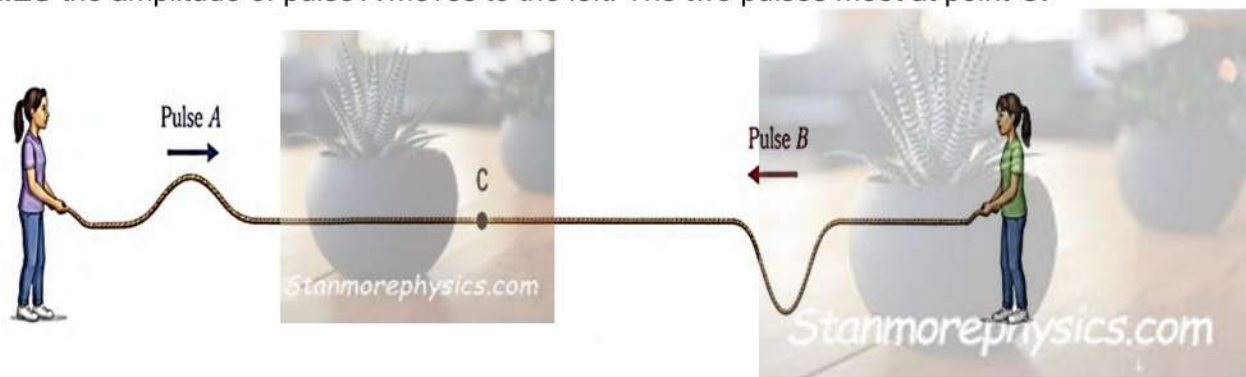

- 2.1 State the *principle of superposition*. (2)
- 2.2 Is the interference at point **C** destructive or constructive interference? (1)
- 2.3 Calculate the resulting amplitude when the two pulses meet at point **C**. (2)
- 2.4 What will happen to amplitude of pulse **A** after two pulses meet? Write only **INCREASE, DECREASE or REMAINS THE SAME**. (1)
- 2.5 Pulse **A** travels a distance of 4 m in 0.5 seconds, calculate the speed of pulse **B**. (3)

[9]

QUESTION 3 (Start on a new page)

The diagram below shows a transverse wave of frequency of 30 Hz moving from left to right.

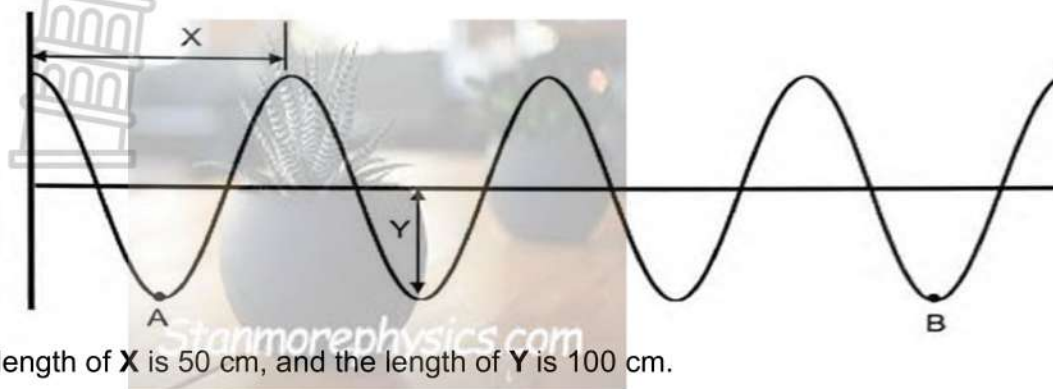

The length of **X** is 50 cm, and the length of **Y** is 100 cm.

- 3.1 Define the term *transverse wave*. (2)
- 3.2 Write down the value of the:
 - 3.2.1 wavelength (1)
 - 3.2.2 amplitude (1)
- 3.3 Calculate the following:
 - 3.3.1 Period (3)
 - 3.3.2 Speed of the wave (3)
 - 3.3.3 Distance between point **A** and point **B** (2)
 - 3.3.4 Time between point **A** and point **B** on the graph (2)
- 3.4 If the distance **Y** on the diagram is **DOUBLED**, what will happen to the frequency of the wave? WRITE ONLY **DOUBLED, HALVED, OR REMAINS CONSTANT**.
 Explain your answer. (2)

[16]

QUESTION 4 (Start on a new page)

4.1 A sound wave produced by a piano is represented in the diagram below.

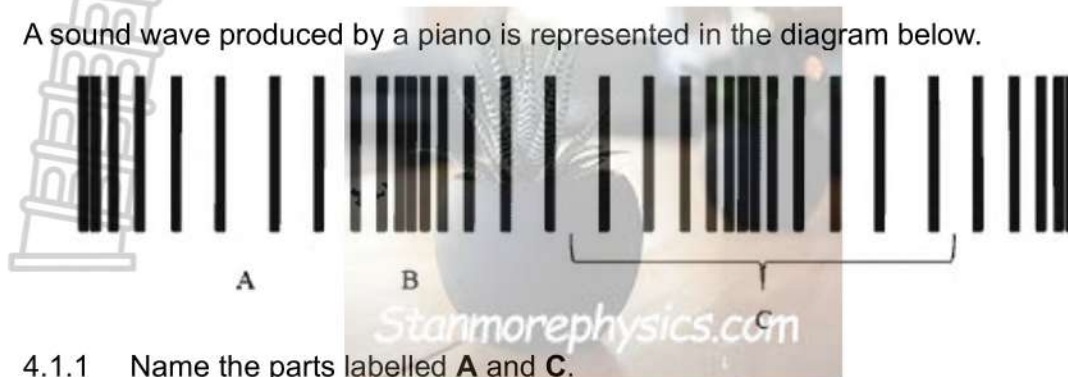

- 4.1.1 Name the parts labelled **A** and **C**. (2)
- 4.1.2 Explain why point **A** and **B** are not in phase. (1)
- 4.1.3 The highest frequency a human ear can hear is 20 kHz.
 If a piano produces a sound wave of wavelength of 10 cm, determine by means of calculations, whether the frequency produced by a piano can be heard by the human ear. (Note: The speed of sound in air is $340 \text{ m}\cdot\text{s}^{-1}$.) (4)
- 4.1.4 What will happen if this piano was played in a vacuum? Explain your answer. (2)

4.2 A boy stands between two birds that are 100 metres apart and blows a whistle once as shown in the diagram below. Bird A hears the sound after 0,094 seconds.



Assume the boy and the birds are on the same horizontal plane and speed of sound in air is $340 \text{ m}\cdot\text{s}^{-1}$

- 4.2.1 Explain the meaning of the word *echo*. (1)
- 4.2.2 Determine by means of calculations which bird (**A** or **B**) will hear the sound first. (5)

[15]

QUESTION 5 (Start on a new page)

The frequency and energy for different types of electromagnetic radiation is presented in the table below:

	Frequency (Hz)	Energy (J)
A	$6,04 \times 10^{10}$	6×10^{-22}
B	$3,03 \times 10^{19}$	Y
C	X	2×10^{-17}

- 5.1 Define the term *photon*. (2)
- 5.2 Use the table above to calculate the:
 - 5.2.1 Energy of radiation B. (3)
 - 5.2.2 Wavelength of radiation C. (4)
- 5.3 Which type of radiation, A, B, or C has the lowest wavelength? Explain your answer. (2)
- 5.4 Draw a graph without showing any values to show the relationship between frequency and penetrating ability. (2)
 - Label frequency on your x-axis and penetrating ability on your Y-axis.
- 5.5 Write down one medical use of x-rays. (1)

[14]

QUESTION 6 (Start on a new page)

The diagram below shows two small identical spheres, **P** and **Q**, on insulated stands. The charge on sphere **P** is $-3 \times 10^{-6} \text{ C}$ and the charge on sphere **Q** is unknown.

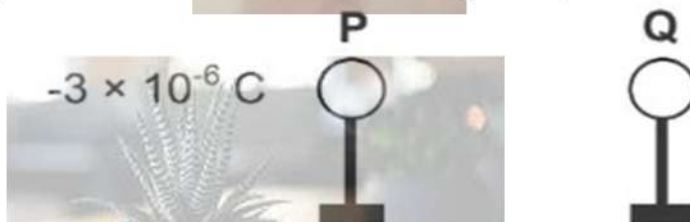

- 6.1 State the *principle of conservation of charge*. (2)
- 6.2 Calculate the number of electrons in excess on sphere **P**. (3)
- 6.3 The two spheres are brought into contact and are then returned to their original positions. Each sphere now carries a charge of $-1 \times 10^{-6} \text{ C}$.
 - 6.3.1 Calculate the original charge on sphere **Q** before the spheres were brought into contact. (3)
 - 6.3.2 Were electrons transferred from **P TO Q** or from **Q TO P** during contact? (1)
 - 6.3.3 Calculate the number of electrons transferred. (4)
- 6.4 What will happen to the charge of spheres if the spheres are placed on metal stands instead of insulated stands. (1)

[14]

QUESTION 7 (Start on a new page)

Circuit 1 and circuit 2 with 14V battery consists of two resistors of $4\ \Omega$ and $8\ \Omega$ respectively, a bulb of resistance of $2\ \Omega$ with ammeter and conducting wires as shown below. Assume that the ammeter and conducting wires have negligible resistance.

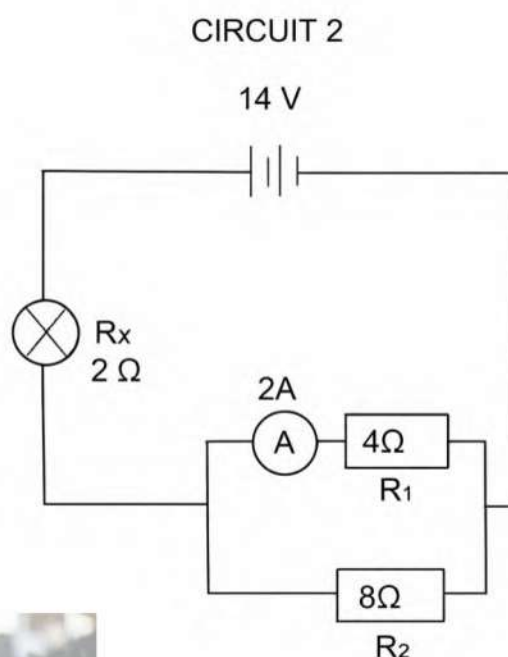
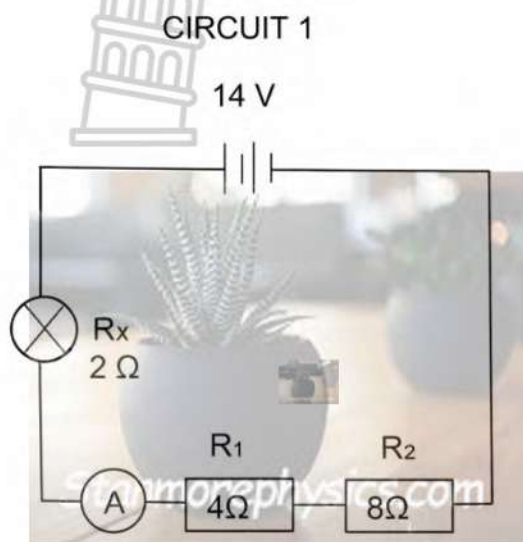

- 7.1 Define the term *current* in words. (2)
- 7.2 Is circuit 2 representing a **SERIES CIRCUIT**, **PARALLEL CIRCUIT** OR **COMBINATION OF SERIES AND PARALLEL CIRCUIT**? (1)
- 7.3 Calculate the total resistance in circuit 2. (4)
- 7.4 Is the ammeter in circuit 1 reading current that is **GREATER THAN**, **SMALLER THAN**, or **EQUAL TO** the current that the ammeter in circuit 2 is reading. Show all calculations. (4)
- 7.5 Determine the charge passing through the $4\ \Omega$ resistor in 3 minutes, in circuit 2. (3)
- 7.6 In which circuit the battery will run out faster between circuit 1 and circuit 2 in the diagrams above. Explain your answer. (2)

[16]

TOTAL: [100]

**DATA FOR PHYSICAL SCIENCES GRADE 10
 PAPER 1 (PHYSICS)**

TABLE 1: PHYSICAL CONSTANTS

NAME	SYMBOL	VALUE
Acceleration due to gravity	g	$9,8 \text{ m}\cdot\text{s}^{-2}$
Speed of light in a vacuum	c	$3,0 \times 10^8 \text{ m}\cdot\text{s}^{-1}$
Planck's constant	h	$6,63 \times 10^{-34} \text{ J}\cdot\text{s}$
Charge on electron	q_e	$-1,6 \times 10^{-19} \text{ C}$
Electron mass	m_e	$9,11 \times 10^{-31} \text{ kg}$

TABLE 2: FORMULAE

WAVES, SOUND AND LIGHT

$v = f\lambda$ or $c = f\lambda$	$T = \frac{1}{f}$
$E = hf$	$E = \frac{hc}{\lambda}$

ELECTROSTATICS

$Q = n \times q_e$	$Q = \frac{Q_1 + Q_2}{2}$
--------------------	---------------------------

ELECTRIC CIRCUITS

$Q = I \times \Delta t$	$\frac{1}{R_p} = \frac{1}{R_1} + \frac{1}{R_2} + \dots$
$R_s = R_1 + R_2 + \dots$	$V = \frac{W}{Q}$
$V = I \times R$	



LIMPOPO

PROVINCIAL GOVERNMENT
REPUBLIC OF SOUTH AFRICA

DEPARTMENT OF

EDUCATION

**NATIONAL
SENIOR CERTIFICATE**

GRADE 10

**PHYSICAL SCIENCES: PHYSICS
(P1)/FISIESE WETENSKAPPE: FISIKA (V1)**

Stanmorephysics.com

JUNE/JUNIE 2026

MARKING GUIDELINES/NASIENRIGLYNE

Stanmorephysics.com

MARKS/PUNTE: 100

This Marking Guideline consist of 10 pages including the cover page./Hierdie nasienriglyn bestaan uit 10 bladsye insluitend die voorblad.

QUESTION 1/VRAAG 1

1.1 **C**✓✓

(2)

1.2 **A**✓✓

(2)

1.3 **C**✓✓

(2)

1.4 **B**✓✓

(2)

1.5 **D**✓✓

(2)

1.6 **B**✓✓

(2)

1.7 **D**✓✓

(2)

1.8 **A**✓✓

(2)

[16]

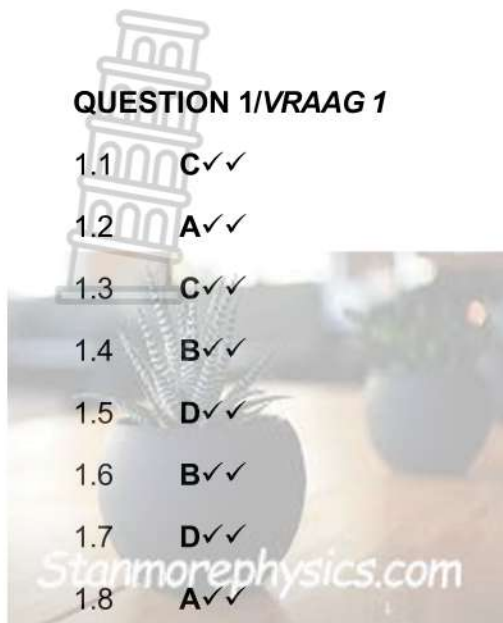

QUESTION 2/VRAAG 2

2.1 Algebraic sum of the amplitudes of two pulses that occupy the same space at the same time. ✓✓ / Algebraïese som van die amplitudes van twee pulse wat dieselfde ruimte op dieselfde tyd beset (2)

2.2 Destructive interference ✓ / Destruktiewe interferensie (1)

2.3 Resulting pulse/resulterende puls = A + B
 = 6 + (- 24) ✓
 = -18 cm ✓
 Amplitude = 18 cm or/of 0,18 m (Accept/aanvaar -18 cm or/of -0,18 m) (2)

2.4 Remains the same. ✓ / Bly dieselfde (1)

2.5 $V_A = \frac{a}{t}$ ✓
 $= \frac{4}{0,5}$ ✓
 $= 8 \text{ m} \cdot \text{s}^{-1}$
 $\therefore V_A = V_B = 8 \text{ m} \cdot \text{s}^{-1}$ ✓ (3)

[9]



QUESTION 3/VRAAG 3

3.1 A wave in which the particles of the medium vibrate at right angles to the direction of motion of the wave. ✓✓ / 'n Golf waarin die deeltjies van die medium reghoekig met die bewegingsrigting van die golf vibreer (2)

3.2

3.2.1 50 cm ✓ or/of 0,5 m (1)

3.2.2 100cm ✓ or/of 1 m (1)

3.3

3.3.1 $T = \frac{1}{f}$ ✓
 $= \frac{1}{30}$ ✓
 $= 0,03 \text{ s}$ ✓ (3)

3.3.2 **OPTION 1/OPSIE 1****POSITIVE MARKING FROM 3.2.1/POSITIEWE NASIEN VANAF 3.2.1**

$$v = f \lambda \checkmark$$

$$= (30)(0,5) \checkmark$$

$$= 15 \text{ m} \cdot \text{s}^{-1} \checkmark$$

$$\lambda = \frac{50}{100} = 0,5 \text{ m}$$

OPTION 2/OPSIE 2**POSITIVE MARKING FROM 3.2.1 AND 3.3.1/POSITIEWE NASIEN VANAF 3.2.1 EN 3.3.1**

$$\text{Speed} = \frac{\text{distance}}{\text{time}} \checkmark / \quad \text{spoed} = \frac{\text{afstand}}{\text{tyd}}$$

$$= \frac{0,5}{0,03} \checkmark$$

$$= 16,67 \text{ m} \cdot \text{s}^{-1} \checkmark \quad \text{Accept/aanvaar: } 15 \text{ m} \cdot \text{s}^{-1} \text{ to } 16,67 \text{ m} \cdot \text{s}^{-1} \quad (3)$$

POSITIVE MARKING FROM 3.2.1/POSITIEWE NASIEN VANAF 3.2.1

3.3.3

Distance = $\lambda \times$ Number of waves / Afstand = $\lambda \times$ aantal golwe

$$= 0,5 \times 3 \checkmark$$

$$= 1,5 \text{ m} \checkmark$$

(2)

3.3.4 **POSITIVE MARKING FROM 3.3.2 AND 3.3.3/ POSITIEWE NASIEN VAN 3.3.2 EN 3.3.3**

OPTION 1/OPSIE 1	OPTION 2/OPSIE 2	OPTION 3/OPSIE 3
$t = 3 \times 0,03 \checkmark$ $= 0,09 \text{ s} \checkmark$	$\text{Speed} = \frac{\text{distance}}{\text{time}}$ $15 = \frac{1,5}{\text{time}} \checkmark$ $\text{time} = \frac{1,5}{15}$ $\text{time} = 0,1 \text{ s} \checkmark$	$\text{Speed} = \frac{\text{distance}}{\text{time}}$ $15 = \frac{0,5}{\text{time}}$ $\text{time for 1 wave} = 0,03 \text{ s}$ $\text{time} = 3 \times 0,03 \checkmark$ $= 0,09 \text{ s} \checkmark$

(2)

3.4 Remains constant ✓ / Bly konstant

-Frequency does not depend on amplitude. ✓ / Frekwensie hang nie van amplitude af nie

(2)

[16]



QUESTION 4/VRAAG 4

4.1

4.1.1 A- Rarefaction ✓/ Verdunning

C- Wavelength ✓/ Golf lengte

4.1.2 - They are not separated by a whole number of wavelengths. ✓/ Hulle word nie deur 'n hele aantal golf lengtes geskei nie (2)

OR/OF

- They are not moving in the same direction at the same time ✓. / Hulle beweeg nie in dieselfde rigting op dieselfde tyd nie (1)

4.1.3 $v = f \lambda$ ✓

$$340 = f (0,1) \quad \checkmark$$

$$f = 3\,400\text{Hz}$$

Yes, ✓/Ja

Human ear can hear the frequency because it is less than 20 000Hz. ✓/

*Die menslike oor kan die frekwensie hoor omdat dit minder as 20 000 Hz is.***OR/OF**

$$3400\text{Hz} < 20\,000\text{Hz}$$

OR/OF

$$3,4\text{kHz} < 20\text{kHz}$$

4.1.4 No sound will be produced. ✓ In vacuum there is no matter which sound can travel on/ sound require a medium to travel on ✓/ *Geen klank sal geproduseer word nie. In vakuum maak dit nie saak watter klank kan beweeg nie/klank benodig 'n medium om te beweeg* (2)

4.2

4.2.1 Reflection of sound from hard surface. ✓/ *Weerspieëling/refleksie van klank vanaf harde oppervlak* (1)

4.2.2 **OPTION 1/OPSIE 1****Bird/Voël A**

$$v = \frac{d}{t} \checkmark$$

$$340 = \frac{d}{0,094} \checkmark$$

$$d = 31,96 \text{ m}$$

Boy is closer to bird A than bird B ✓, therefore Bird A will hear the sound first. ✓ / Seun is nader aan voël A as voël B, daarom sal Voël A die geluid eerste hoor.

OPTION 2/OPSIE 2

$$v = \frac{d}{t} \checkmark$$

$$340 = \frac{d}{0,094} \checkmark$$

$$d = 31,96 \text{ m}$$

$$\text{distance of bird A/afstand vanaf voël A} = 31,96 \text{ m}$$

$$\text{Distance of bird B/afstand vanaf voël B}$$

$$= 100 - 31,96$$

$$= 68,04 \text{ m}$$

$$\text{speed/spoed} = \frac{d}{t}$$

$$340 = \frac{68,04}{t} \checkmark$$

$$t = 0,20 \text{ s}$$

It will take more time for sound to reach bird B than bird A ✓, therefore bird A is closer to the boy. ✓ / Dit sal meer tyd neem vir klank om voël B te bereik as voël A, daarom is voël A nader aan die seun.

(5)

[15]

QUESTION 5/VRAAG 5

5.1 Packet of energy found in light. ✓✓/ *Pakkie energie wat in lig gevind word* (2)

5.2

5.2.1 $E = hf$ ✓
 $= (6,63 \times 10^{-34})(3,03 \times 10^{19})$ ✓
 $= 2,01 \times 10^{-14}J$ ✓ (3)

5.2.2 $E = \frac{hc}{\lambda}$ ✓
 $2 \times 10^{-17} = \frac{(6,63 \times 10^{-34})(3 \times 10^8)}{\lambda}$ ✓
 $\lambda = 9,95 \times 10^{-9}m$ ✓ Accept/aanvaar: $9,95 \times 10^{-9}m$ (4)

5.3 B ✓, it has the greatest frequency. ✓/ *dit het die grootste frekwensie*
Or/Of
 B, it has the greatest energy. / *dit het die hoogste energie* (2)

5.4 Frequency vs penetrating ability graph/ *Frekwensie teenoor penetrasievermoë-grafiek*

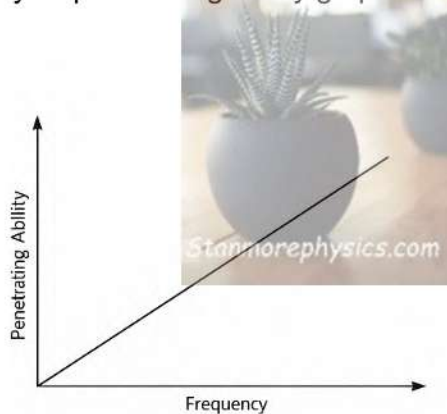

Marking criteria/Nasien kriteria

Criteria/kriteria

	Marks/Punte	
Correct labelling of axes/ <i>korrekte opskrifte vir asse</i>	1	
Correct shape of the graph/ <i>korrekte vorm van grafiek</i>	1	(2)

- 5.2
- Scan bones/create image of body's internal structures ✓/ *Skandeer bene/skep beeld van die liggaam se interne strukture*
 - Detect injuries ✓/ *Bespour beserings*
 - To detect tumors ✓/ *Om gewasse op te spoor*

Any correct Answer, ONE MARK/ Enige korrekte antwoord, EEN PUNT

(1)

[14]

QUESTION 6/VRAAG 6

6.1 The net charge of an isolated system remains constant during any physical process. ✓✓ / Die netto lading van 'n geïsoleerde stelsel bly konstant tydens enige fisiese proses. (2)

6.2 $n = \frac{Q}{qe}$ ✓
 $= \frac{-3 \times 10^{-6}}{-1,6 \times 10^{-19}}$ ✓
 $= 1,875 \times 10^{13}$ electrons/elektrone ✓ (3)

6.3

6.3.1 $Q_{\text{new}} = \frac{Q_1 + Q_2}{2}$ ✓
 $-1 \times 10^{-6} = \frac{(-3 \times 10^{-6}) + Q_Q}{2}$ ✓

$$2(-1 \times 10^{-6}) = -3 \times 10^{-6} + Q_Q$$

$$Q_Q = 1 \times 10^{-6} \text{ C} \quad \checkmark$$

6.3.2 P to Q ✓ (3)

6.3.3 **OPTION 1/OPSIE 1**

$$n = \frac{\Delta Q}{qe} \quad \checkmark$$

$$n = \frac{Q_{\text{new}} - Q_{\text{old}}}{qe}$$

$$\frac{(-1 \times 10^{-6}) - (-3 \times 10^{-6})}{1,6 \times 10^{-19}} \checkmark$$

$$= 1,25 \times 10^{13}$$

electrons/elektrone ✓

OPTION 2/OPSIE 2

$$n = \frac{\Delta Q}{qe} \quad \checkmark$$

$$n = \frac{Q_{\text{new}} - Q_{\text{old}}}{qe}$$

$$\frac{(-1 \times 10^{-6}) - (1 \times 10^{-6})}{1,6 \times 10^{-19}} \checkmark$$

$$= 1,25 \times 10^{13} \text{ electrons/elektrone} \quad \checkmark$$

6.4 The charges on spheres will leak away into the ground. ✓✓ / Die ladings op sferes sal in die grond weglek (4)

OR/OF

Spheres will lose a charge and become neutral. ✓✓ / Sferes sal 'n lading verloor en neutraal word (1)

[14]

QUESTION 7/VRAAG 7

7.1 Current- Rate of flow of charge. ✓✓/ *Stroom - Tempo van vloeï van lading* (2)

7.2 Combination of series and parallel circuit. ✓/ *Kombinasie van serie- en parallelstroombane* (1)

7.3 OPTION 1/OPSIE 1

$$\frac{1}{R_p} = \frac{1}{R_1} + \frac{1}{R_2} \checkmark$$

$$\frac{1}{R_p} = \frac{1}{4} + \frac{1}{8} \checkmark$$

$$\frac{1}{R_p} = \frac{3}{8}$$

$$R_p = \frac{8}{3}$$

OPTION 2/OPSIE 2

$$R_p = \frac{R_1 R_2}{R_1 + R_2} \checkmark$$

$$= \frac{4 \times 8}{4 + 8} \checkmark$$

$$= 2,67 \Omega$$

$R_p = 2,67 \Omega$

$R_T = R_S + R_P$
 $= 2 + 2,67 \checkmark$
 $= 4,67 \Omega \checkmark$



7.4 Smaller than/Kleiner as, ✓
 $R_T = R_1 + R_2 + R_3$
 $= 2 + 4 + 8 \checkmark$
 $= 14 \Omega$ (4)

$V = IR \checkmark$
 $14 = 1(14)$
 $I = 1 A \checkmark$

7.5

$$I = \frac{Q}{\Delta t} \checkmark$$

$$2 = \frac{Q}{3 \times 60} \checkmark$$

$$Q = 2 \times 3 \times 60$$

$$Q = 360 C \checkmark$$

7.6 Circuit 2 ✓/ *Stroombaan 2*
 - Circuit 2 has lower resistance allowing a battery to supply more current. ✓/ *Stroombaan 2 het laer weerstand wat 'n battery toelaat om meer stroom te lewer* (2)

[16]

TOTAL/TOTAAL: [100]