



**LIMPOPO**  
PROVINCIAL GOVERNMENT  
REPUBLIC OF SOUTH AFRICA

DEPARTMENT OF  
**EDUCATION**

**NATIONAL SENIOR  
CERTIFICATE**

**GRADE 11**

**PHYSICAL SCIENCES: PHYSICS (P1)**

Stanmorephysics.com  
**JUNE 2026**

Stanmorephysics.com

**MARKS : 100**

**TIME : 2 HOURS**

**This question paper consists of 13 pages including data sheets.**

## INSTRUCTIONS AND INFORMATION

1. Write your name on the ANSWER SHEET.
2. This question paper consists of EIGHT questions. Answer ALL the questions in the ANSWER SHEET
3. Start EACH question on a NEW page in the ANSWER SHEET.
4. You may use a non-programmable calculator.
5. You may use appropriate mathematical instruments.
6. Number the answers correctly according to the numbering system used in this question paper.
7. Leave ONE line between two sub questions, for example between QUESTION 2.1 and QUESTION 2.2
8. You are advised to use the attached DATA SHEETS.
9. Give brief motivations, discussions, et cetera where required
10. Round off your final numerical answers to a minimum of TWO decimal places.
11. Show ALL formulae and substitutions in ALL calculations.
12. Write neatly and legibly.



**QUESTION 1**

Four options are provided as possible answers to the following questions. Each question has only ONE correct answer. Choose the answer and write down only the letter A, B, C or D next to the question number (1.1–1.5) in your ANSWER BOOK.

1.1 In which of the following vector diagrams is the resultant of the three vectors zero?

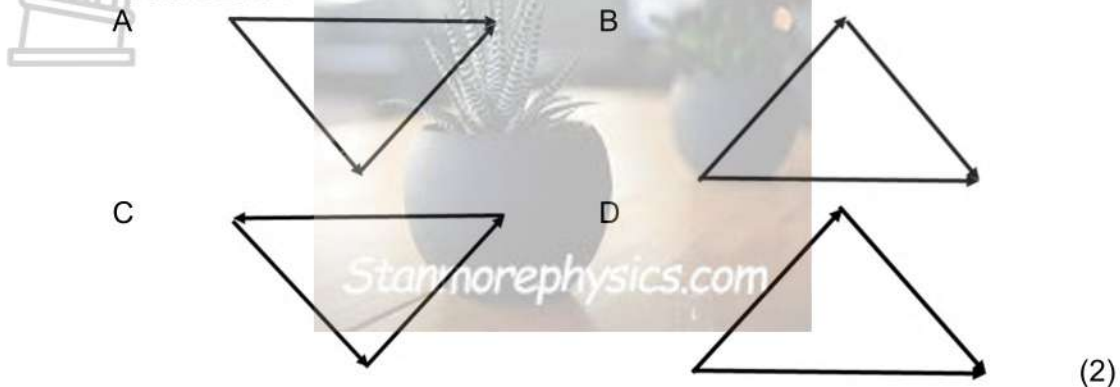

1.2 Newton's second law of motion can be expressed as  $F_{\text{net}} = ma$ . This equation consists of ...

- A one vector quantity and two scalar quantities.
  - B two vector quantities and one scalar quantity.
  - C three vector quantities.
  - D three scalar quantities.
- (2)

1.3 The magnitude of the electrostatic force exerted by charge  $Q_1$  on charge  $Q_2$  is  $F$ . When the distance between the two charges is tripled, the magnitude of the electrostatic force in terms of  $F$ , will now be

- A  $\frac{1}{9}F$
  - B  $\frac{1}{3}F$
  - C  $3F$
  - D  $9F$
- (2)

1.4 Two charges of +2 nC and -2 nC are located on a straight line. S and T are two points that lie on the same straight line as shown in the diagram below.



Which ONE of the following correctly represents the directions of the RESULTANT electric fields at S and T?

|   | Direction of the resultant electric field at point S | Direction of the resultant electric field at point T |
|---|--|--|
| A | Left   | Left   |
| B | Right  | Left   |
| C | Left   | Right  |
| D | Right  | Right  |

(2)

1.5 5 Ω and 10 Ω resistors are connected in parallel as shown in the diagram.

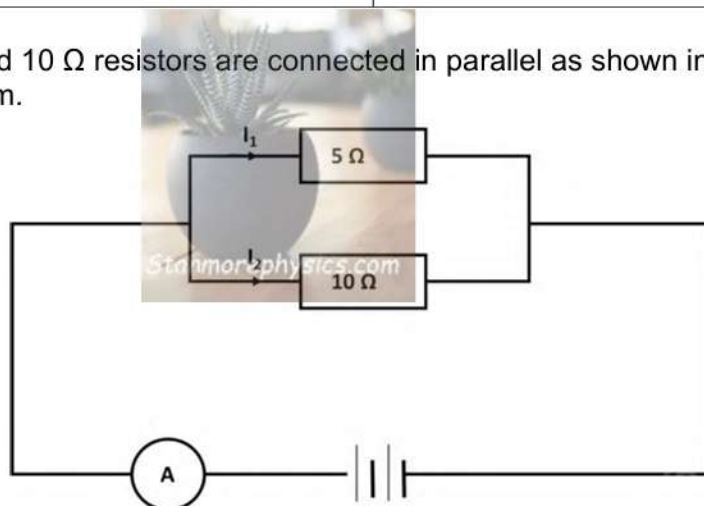

The relationship between current  $I_1$  and current  $I_2$  can be expressed as:

- A  $I_2 = I_1$
- B  $I_2 = \frac{1}{3}I_1$
- C  $I_2 = \frac{3}{2}I_1$
- D  $I_2 = \frac{1}{2}I_1$

(2)  
 [10]

### QUESTION 2

A heavy object of mass 130 kg is suspended in a stationary position by two ropes, **A** and **B**. Rope **A** makes an angle of  $70^\circ$  with the horizontal and rope **B** makes an angle of  $10^\circ$  with the vertical.

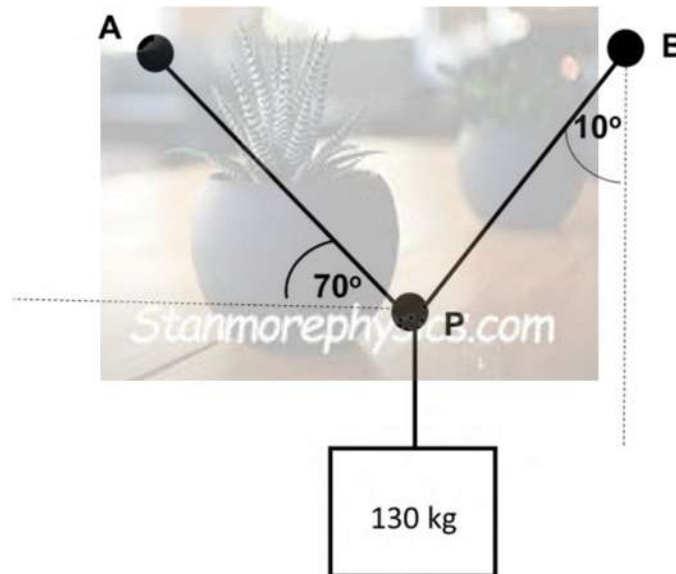

- 2.1 State the condition for a system to be in equilibrium. (2)
  - 2.2 Draw a free-body diagram representing all the forces acting on point **P**. (3)
  - 2.3 Calculate the tensions in ropes **A** and **B**. (5)
  - 2.4 The mass of the object is doubled without changing the ropes.  
Explain what will happen to the system or object. (2)
- [12]**

### QUESTION 3

Consider a two-body problem in which two known masses are held over a low-friction pulley by a very tight string as shown in the diagram.

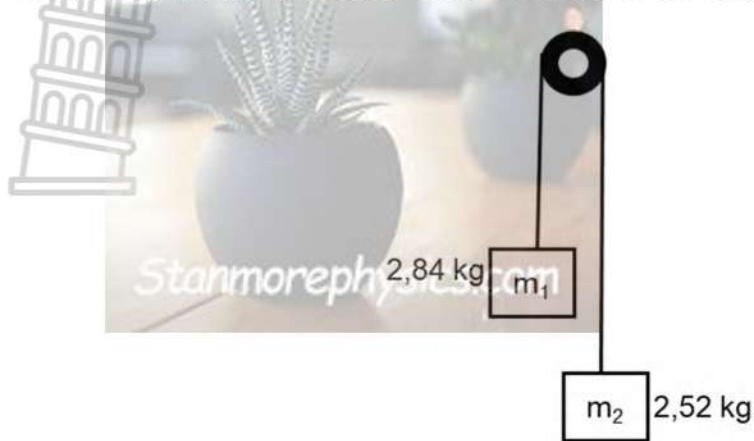

- 3.1 State *Newton's Second Law of motion*. (2)
- 3.2 When the masses are released, in what direction will
- 3.2.1  $m_1$  travel? (1)
- 3.2.2  $m_2$  travel? (1)
- 3.3 How will the acceleration of  $m_1$  compare to the acceleration of  $m_2$ ? Explain. (2)
- 3.4 How does the net force on  $m_1$  compare to the net force on  $m_2$ ? Explain. (2)
- 3.5 Why are 'very-light string' and 'low friction pulley' important elements of this problem? (2)

[10]

**QUESTION 4**

A block of mass 25 kg is placed on a rough surface inclined at  $30^\circ$  to the horizontal. A constant force **F**, acting parallel to the surface, is applied on the block so that the block moves up the incline at a CONSTANT VELOCITY of  $2 \text{ m}\cdot\text{s}^{-1}$ . Refer to the diagram below. A constant kinetic frictional force of 18 N acts on the block.

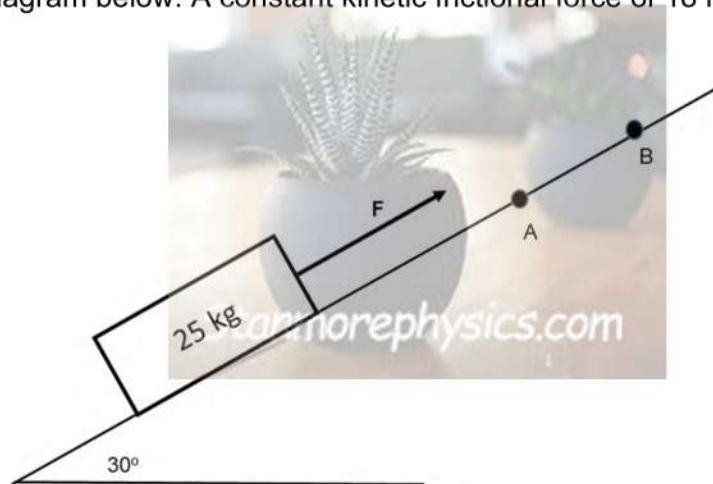

- 4.1 State *Newton's First Law of motion*. (2)
- 4.2 Draw a free-body diagram for the block. (4)
- 4.3 Calculate the magnitude of force **F**. (3)

Force **F** is removed when the block reaches point **A** on the surface. The block continues to move up the surface and comes to rest momentarily at point **B**. Assume that the kinetic frictional force acting on the block remains at 18 N as it moves from point **A** to point **B**.

- 4.4 Write down the net force acting on the block as it moves from point **A** to point **B**. (2)

**[11]**

**QUESTION 5**

A satellite of mass 600 kg orbits the Earth at a height of 2 000 km above the Earth's surface.

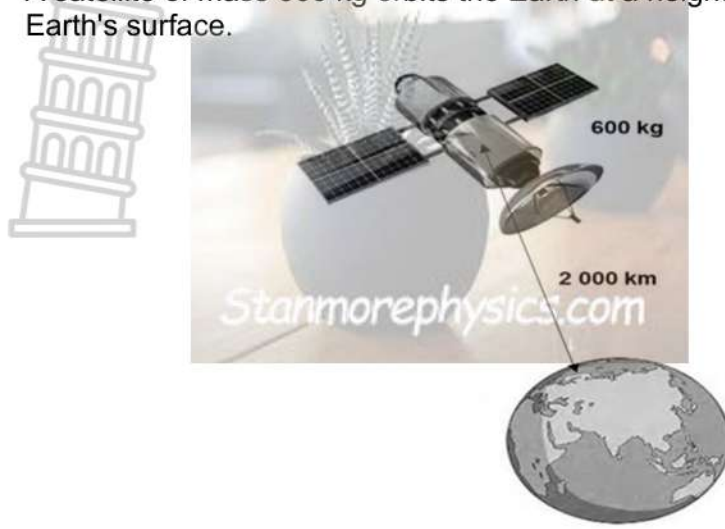

- 5.1 5.1.1 State *Newton's Law of Universal Gravitation* in words. (2)
- 5.1.2. Why is the distance  $r$  in the formula measured from the centres of the two objects rather than their surfaces? (2)
- 5.1.3. Calculate the gravitational force exerted by the Earth on the satellite. (4)
- 5.1.4. If the distance between the satellite and the centre of the Earth were **doubled**, by what factor would the gravitational force change? (Use the Inverse Square Law to justify). (2)
- 5.2 A parachutist feels no contact forces while falling in the atmosphere. Name the term used to explain the phenomenon. (1)
- [11]**

**QUESTION 6**

Two identical spheres, **P** and **T**, carrying charges of  $+5 \times 10^{-6} \text{ C}$  and  $-3 \times 10^{-6} \text{ C}$  respectively, are placed a distance of 0,1 m apart.

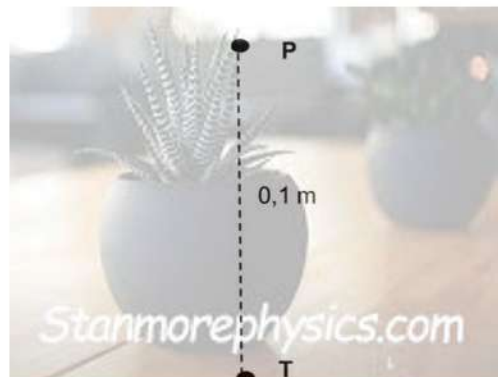
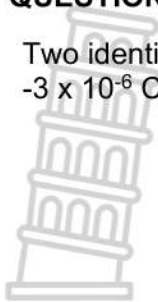

- 6.1 State *Coulomb's law* in words. (2)
- 6.2 Calculate the electrostatic force between the spheres (4)
- 6.3 Draw the resultant electric field pattern due to the charges on **P** and **T**. (3)

The two spheres touch and separate, and return to the original positions.

- 6.4 Calculate the new charge of each. (3)
- 6.5 Consider a point **Q** at a distance of 0,15 m from sphere **T** such that the three points, **P**, **Q** and **T** are at the vertices of a right-angled triangle after the two spheres touched and separated.

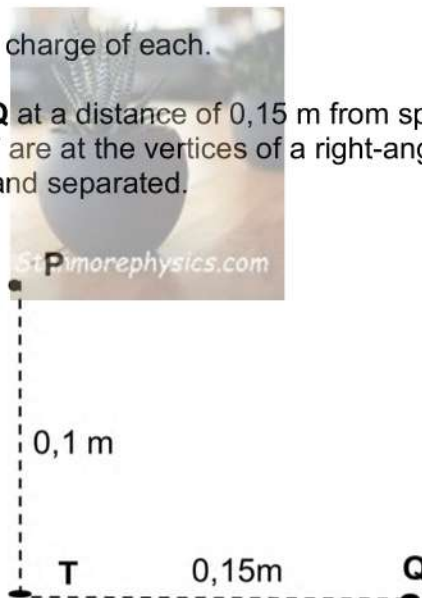

- 6.5.1 Define the *electric field at a point*. (2)
- 6.5.2 Calculate the magnitude of the electric field on **Q** due to **P**. (4)
- 6.5.3 Calculate the magnitude of the electric field on **Q** due to **T**. (2)

**[20]**

### QUESTION 7

The following diagram shows a solenoid **AB** connected to a galvanometer (able to record very small currents). The magnet is now moved as indicated.

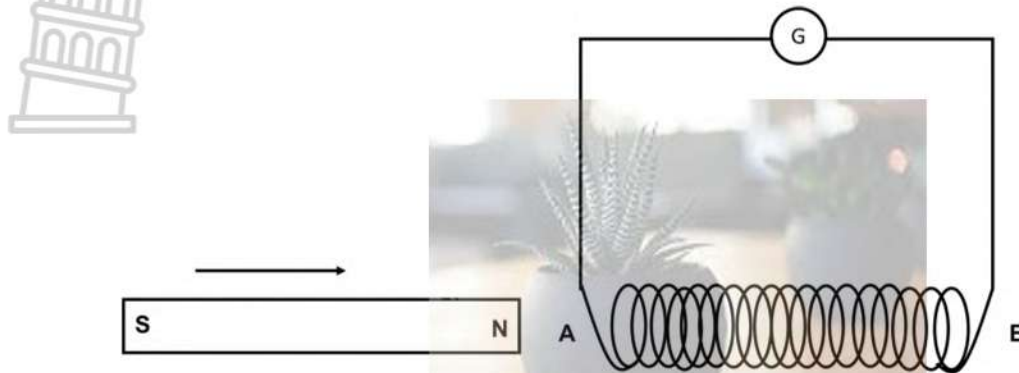

- 7.1 State *Faraday's law of electromagnetic induction*, in words. (2)
- 7.2 State what will happen to the reading on the galvanometer when:
- 7.2.1 The magnet is pushed into the solenoid (1)
- 7.2.2 The magnet is held still inside the solenoid (1)
- 7.3 The magnet is moved into the solenoid.
- 7.3.1 Identify the polarity of point **A** on the solenoid. (1)
- 7.3.2 Indicate the direction a current will flow in the solenoid: **A to B** or **B to A**. (2)
- 7.3.3 Explain the rule and how you used it to get the answer to QUESTION 7.3.2. (2)

[9]

**QUESTION 8**

Three IDENTICAL light-bulbs **A**, **B** and **C** each with a resistance of  $4,5 \Omega$  are connected to a battery with emf  $24 \text{ V}$  and unknown internal resistance, as shown in circuit diagram below. The resistance of the connecting wires and the ammeter may be ignored.

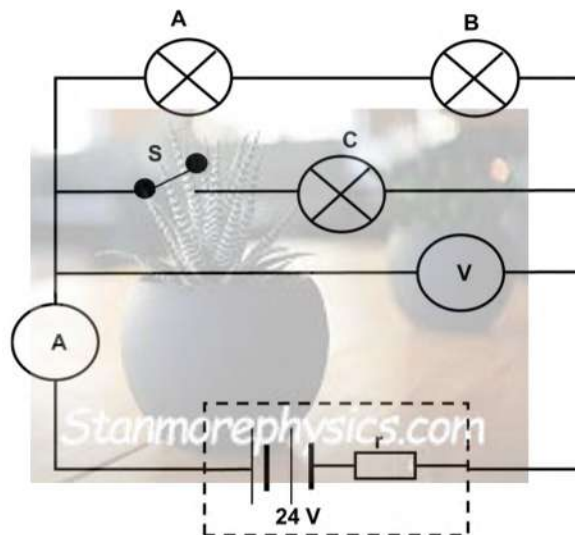

Switch **S** is open. The ammeter reading is  $2 \text{ A}$ .

8.1 Define the term *electrical power* in words. (2)

8.2 Calculate the:

8.2.1 Reading on the voltmeter. (4)

8.2.2 Internal resistance of the battery. (3)

Switch **S** is now closed.

8.3 Compare the brightness of the light-bulbs **A**, **B** and **C**. Justify the answer. (4)

8.4 How would the voltmeter reading change? Choose from INCREASES, DECREASES or REMAINS THE SAME. Explain the answer. (4)

[17]

**TOTAL: 100**

PHYSICAL SCIENCES GRADE 11 DATA SHEET

TABLE 1: PHYSICAL CONSTANTS/TABEL 1: FISIESE KONSTANTES

| NAME/NAAM  | SYMBOL/SIMBOOL | VALUE/WAARDE  |
|--|----------------|---|
| Acceleration due to gravity<br><i>Swaartekragversnelling</i>   | g              | 9,8 m·s <sup>-2</sup>                                       |
| Gravitational constant<br><i>Swaartekragkonstante</i>          | G              | 6,67 x 10 <sup>-11</sup> N·m <sup>2</sup> ·kg <sup>-2</sup> |
| Radius of Earth<br><i>Straal van Aarde</i>                     | R <sub>E</sub> | 6,38 x 10 <sup>6</sup> m                                    |
| Coulomb's constant<br><i>Coulomb se konstante</i>              | k              | 9,0 x 10 <sup>9</sup> N·m <sup>2</sup> ·C <sup>-2</sup>     |
| Speed of light in a vacuum<br><i>Spoe van lig in 'n vakuum</i> | c              | 3,0 x 10 <sup>8</sup> m·s <sup>-1</sup>                     |
| Charge on electron<br><i>Lading op elektron</i>                | e              | -1,6 x 10 <sup>-19</sup> C                                  |
| Electron mass<br><i>Elektronmassa</i>                          | m <sub>e</sub> | 9,11 x 10 <sup>-31</sup> kg                                 |
| Mass of the Earth<br><i>Massa van die Aarde</i>                | M              | 5,98 x 10 <sup>24</sup> kg                                  |

TABLE 2: FORMULAE/TABEL 2: FORMULES

MOTION/BEWEGING

|                               |  |
|-------------------------------|--|
| $v_f = v_i + a \Delta t$      | $\Delta x = v_i \Delta t + \frac{1}{2} a \Delta t^2$     |
| $v_f^2 = v_i^2 + 2a \Delta x$ | $\Delta x = \left( \frac{v_f + v_i}{2} \right) \Delta t$ |

FORCE/KRAG

|                           |                                       |
|---------------------------|---------------------------------------|
| $F_{\text{net}} = ma$     | $w = mg$                              |
| $F = \frac{Gm_1m_2}{r^2}$ | $\mu_s = \frac{f_{s(\text{max})}}{N}$ |
| $\mu_k = \frac{f_k}{N}$   |                                       |

**WAVES, SOUND AND LIGHT/GOLWE, KLANK EN LIG**

|   |                   |
|---|-------------------|
| $v = f\lambda$                          | $T = \frac{1}{f}$ |
| $n_i \sin \theta_i = n_r \sin \theta_r$ | $n = \frac{c}{v}$ |

**ELECTROSTATICS/ELEKTROSTATIKA**

|  |                   |
|--|-------------------|
| $F = \frac{kQ_1Q_2}{r^2}$ ( $k = 9,0 \times 10^9 \text{ N}\cdot\text{m}^2\cdot\text{C}^{-2}$ ) | $E = \frac{F}{Q}$ |
| $E = \frac{kQ}{r^2}$ ( $k = 9,0 \times 10^9 \text{ N}\cdot\text{m}^2\cdot\text{C}^{-2}$ )      | $V = \frac{W}{Q}$ |

**ELECTROMAGNETISM/ELEKTROMAGNETISME**

|   |                         |
|---|-------------------------|
| $\epsilon = -N \frac{\Delta\Phi}{\Delta t}$ | $\Phi = BA \cos \theta$ |
|---|-------------------------|

**CURRENT ELECTRICITY/STROOMELEKTRISITEIT**

|   |                               |
|---|-------------------------------|
| $I = \frac{Q}{\Delta t}$  | $R = \frac{V}{I}$             |
| $\frac{1}{R} = \frac{1}{r_1} + \frac{1}{r_2} + \frac{1}{r_3} + \dots$ | $R = r_1 + r_2 + r_3 + \dots$ |
| $W = Vq$  | $P = \frac{W}{\Delta t}$      |
| $W = VI\Delta t$  | $P = VI$                      |
| $W = I^2R\Delta t$  | $P = I^2R$                    |
| $W = \frac{V^2\Delta t}{R}$   | $P = \frac{V^2}{R}$           |



LIMPOPO

PROVINCIAL GOVERNMENT  
REPUBLIC OF SOUTH AFRICA

DEPARTMENT OF  
**EDUCATION**

NATIONAL SENIOR  
CERTIFICATE

GRADE 11

PHYSICAL SCIENCES: PHYSICS (P1)/FISIESE WETENSAPPE:  
FISIKA (V1)

MARKING GUIDELINE/NASIENRIGLYNE

JUNE 2026/JUNIE 2026

MARKS/PUNTE: 100

This marking guideline consists of 9 pages/*Hierdie nasienriglyne bestaan uit 9 bladsye*

**QUESTION/VRAAG 1**

- 1.1 C ✓✓ (2)
- 1.2 B ✓✓ (2)
- 1.3 A ✓✓ (2)
- 1.4 B ✓✓ (2)
- 1.5 D ✓✓ (2)

[10]

**QUESTION/VRAAG 2**

2.1 The vector diagram for the forces acting on the object must be closed. ✓✓ / Die vektordiagram vir die kragte wat op die voorwerp inwerk, moet geslote wees.

**OR/OF**

The vector sum of all the forces acting on the object must be zero / Die vektorsom van al die kragte wat op die voorwerp inwerk, moet nul wees.

**OR/OF**

The object must either be at rest or move at a constant velocity. / Die voorwerp moet óf in rus wees óf teen 'n konstante snelheid beweeg

**OR/OF**

The object must experience no acceleration. / Die voorwerp moet geen versnelling ervaar nie

(2)

2.2

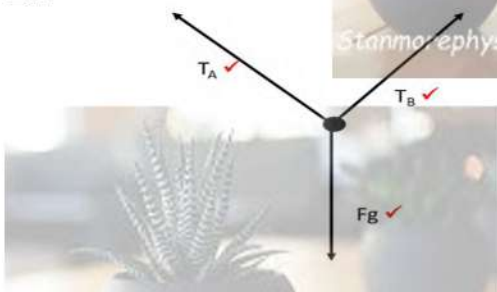

**Accept/Aanvaar:**

|       |  |
|-------|--|
| $F_g$ | W/Weight/Force of gravity/gewig/gravitasiekrag |
|-------|--|

(3)

2.3

|   |   |
|---|---|
| <p><b>OPTION 1/OPSIE 1</b><br/>                 Horizontal/horizontaal:<br/> <math>T_A \cos(70^\circ) = T_B \sin(10^\circ)</math> ✓<br/> <math>T_A = \frac{T_B \sin(10^\circ)}{\cos(70^\circ)}</math><br/>                 Vertical/vertikaal:<br/> <math>T_A \sin(70^\circ) + T_B \cos(10^\circ) = F_g</math> ✓<br/>                 But, <math>F_g = 130 \times 9,8 = 1274 \text{ N}</math><br/> <math>T_A \sin(70^\circ) + T_B \cos(10^\circ) = 1274</math> ✓<br/> <math>\frac{T_B \sin(10^\circ)}{\cos(70^\circ)} \sin(70^\circ) + T_B \cos(10^\circ) = 1274</math><br/> <math>T_B = 871,467 \text{ N}</math> ✓<br/> <math>T_A = 442,456 \text{ N}</math> ✓</p> | <p><b>OPTION 3/OPSIE 3</b><br/> <math>\frac{\sin A}{A} = \frac{\sin B}{B} = \frac{\sin C}{C}</math><br/> <math>\frac{\sin(150^\circ)}{130 \times 9,8} = \frac{\sin(20^\circ)}{T_B}</math> ✓<br/> <math>\frac{\sin(150^\circ)}{130 \times 9,8} = \frac{\sin(20^\circ)}{T_B}</math> ✓<br/> <math>T_B = 871,47 \text{ N}</math> ✓<br/> <math>\frac{\sin(150^\circ)}{130 \times 9,8} = \frac{\sin(10^\circ)}{T_A}</math> ✓<br/> <math>T_A = 442,46 \text{ N}</math> ✓</p> |
|---|---|

**OPTION 2/OPSIE 2**

Horizontal/horizontaal:  $T_A \cos(70^\circ) = T_B \sin(10^\circ)$  ✓

$$T_B = \frac{T_A \cos(70^\circ)}{\sin(10^\circ)}$$

Vertical/vertikaal:  $T_A \sin(70^\circ) + T_B \cos(10^\circ) = F_g$  ✓

But/maar,  $F_g = 130 \times 9,8 = 1274 \text{ N}$

$T_A \sin(70^\circ) + T_B \cos(10^\circ) = 1274$  ✓

$T_A \sin(70^\circ) + \frac{T_A \cos(70^\circ)}{\sin(10^\circ)} \cos(10^\circ) = 1274$

$T_A = 442,456 \text{ N}$  ✓

$T_B = 871,467 \text{ N}$  ✓

(5)

2.4 The object will fall ✓ as there will be a resultant force ✓. / Die voorwerp sal val omdat daar 'n resulterende krag sal wees

**OR/OF**

The object will accelerate downwards. ✓✓ / Die voorwerp sal afwaarts versnel

**OR/OF**

The vector diagram of the forces will be open. ✓✓ / Die vektordiagram van die kragte sal oop wees

(2)

[12]

**QUESTION 3/VRAAG 3**

3.1 When a net force acts on an object, the object will accelerate in the direction of the force, and the acceleration is directly proportional to the force and inversely proportional to the mass of the object. ✓✓ / Wanneer 'n netto krag op 'n voorwerp inwerk, sal die voorwerp in die rigting van die krag versnel en die versnelling is direk eweredig aan die krag en omgekeerd eweredig aan die massa van die voorwerp. (2/0) (2)

3.2 3.2.1. Downwards ✓ / Afwaarts (1)

3.2.2. Upwards ✓ / Opwaarts (1)

3.3 REMAINS THE SAME. ✓ / BLY DIESELFDE

Since the masses are connected by a light inextensible string, the masses move together ✓ / Aangesien die massas deur 'n ligte, onrekbare toutjie verbind is, beweeg die massas saam

**OR/OF**

their speeds/velocities change at the same rate/ hul snelhede/spoed verander teen dieselfde tempo (2)

3.4 Greater than. ✓ / Groter as.  $m_1$  is greater than  $m_2$  ( $m_1 > m_2$ ), and  $a$  is the same, therefore  $m_1 a > m_2 a$  or  $F_{net1} > F_{net2}$  ✓. /  $m_1$  is groter as  $m_2$  ( $m_1 > m_2$ ), en  $a$  is dieselfde, daarom  $m_1 a > m_2 a$  of  $F_{net1} > F_{net2}$  (2)

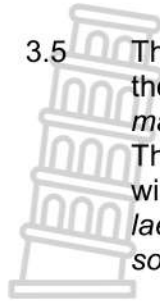

3.5 The string must provide constant tension between the masses in the system ✓ / Die tou moet konstante spanning tussen die massas in die stelsel bied.

The low friction pulley is there to change the direction of the force without affecting its magnitude through friction. ✓ / Die laewrywingskatrol is daar om die rigting van die krag te verander sonder om die grootte daarvan deur wrywing te beïnvloed.

(2)  
[10]

**QUESTION 4/VRAAG 4**

4.1 A body will remain in its state of rest or motion at constant velocity unless a non-zero resultant/net force acts on it. ✓✓ / 'n Liggaam sal in sy toestand van rus of beweging teen konstante snelheid bly, tensy 'n nie-nul resulterende/netto krag daarop inwerk. (2/0) (2)

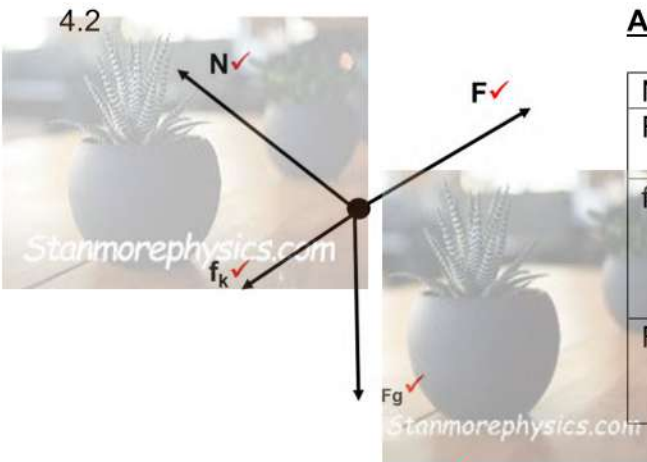

**Accept/Aanvaar:**

|                |   |
|----------------|---|
| N              | F <sub>N</sub> ; Normal/normaal   |
| F              | F <sub>a</sub> /force applied/krag toegepas                                   |
| f <sub>k</sub> | Frictional force/Kinetic frictional force/wrywingskrag/kinetiese wrywingskrag |
| F <sub>g</sub> | W/Weight; Force of gravity/gewig, gravitasiekrag                              |

(4)

4.3  $F + (-f_k) + (-F_{g//}) = ma$  ✓  
 $F + (-18) + (-25 \times 9,8 \sin 30^\circ) = 0$  ✓  
 $F = 140,5 \text{ N}$  ✓

(3)

4.4  $F_{\text{net}} = F_{g//} + f_k$   
 $= (25 \times 9,8 \times \sin 30^\circ) + (-18)$  ✓  
 $= -140,5 \text{ N}$  ✓

(2)  
[11]

**QUESTION 5/VRAAG 5**

5.1.1 Newton's law of universal gravitation states that each particle in the universe attracts every other particle with a gravitational force that is directly proportional to the product of their masses and inversely proportional to the square of the distance between their centres. ✓✓ / Newton se wet van universele gravitasie bepaal dat elke deeltjie in die heelal elke ander deeltjie aantrek met 'n gravitasiekrag wat direk eweredig is aan die produk van hul massas en omgekeerd eweredig aan die kwadraat van die afstand tussen hul middelpunte. (2/0) (2)

5.1.2  $r$  is measured from the centre of masses as it allows the complex or extended objects to be treated as simple point masses. ✓✓ /  $r$

word gemeet vanaf die middelpunt van massas, aangesien dit toelaat dat die komplekse of uitgebreide voorwerpe as eenvoudige puntmassas behandel word.

**OR/OF**

the uneven objects have their masses concentrated at their centres, therefore  $r$  is measured from the centre. ✓✓/ Die ongelyke voorwerpe het hul massas gekonsentreer by hul middelpunte, daarom word  $r$  vanaf die middelpunt gemeet. (2)

5.1.3  $F = \frac{Gm_1m_2}{r^2}$  ✓  
 $F = \frac{6,67 \times 10^{-11} \times 5,98 \times 10^{24} \times 600}{(6,38 \times 10^6 + 2,0 \times 10^6)^2}$  ✓  
 $F = 3407,93 \text{ N}$  ✓ (4)

5.1.4  $F \propto \frac{1}{r^2}$  ✓  
 If  $r$  is doubled ( $2r$ ), the force becomes/ As  $r$  verdubbel word ( $2r$ ), word die krag  $\frac{1}{2^2} = \frac{1}{4}$ .  
 The force will decrease by a factor of 4 ✓✓/ Die krag sal met 'n faktor van 4 afneem

**OR/OF**

new force is  $\frac{1}{4} F$ / nuwe krag is  $\frac{1}{4} F$  (2)

5.2 Weightlessness ✓✓/ Gewigloosheid (1)  
**[11]**

**QUESTION 6/VRAAG 6**

6.1 The magnitude of the electrostatic force exerted by two point charges ( $Q_1$  and  $Q_2$ ) on each other is directly proportional to the product of the magnitudes of the charges and inversely proportional to the square of the distance ( $r$ ) between them. ✓✓/ Die grootte van die elektrostatische krag wat deur twee puntladings ( $Q_1$  en  $Q_2$ ) op mekaar uitgeoefen word, is direk eweredig aan die produk van die groottes van die ladings en omgekeerd eweredig aan die kwadraat van die afstand ( $r$ ) tussen hulle. (2/0) (2)

6.2  $F = k \frac{Q_1Q_2}{r^2}$  ✓  
 $F = (9 \times 10^9) \frac{(5 \times 10^{-6})(3 \times 10^{-6})}{(0,1)^2}$  ✓  
 $F = 13,5 \text{ N}$  ✓ (4)



6.3

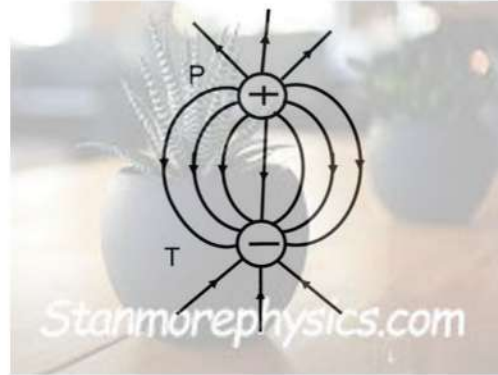

| Marking Criteria/Nasien kriteria  | Marks/Punte |
|---|-------------|
| Correct shape/korrekte vorm   | ✓           |
| Field lines are at right angle with the charges and never cross each other/ Veldlyne is reghoekig met die ladings en kruis mekaar nooit | ✓           |
| Direction: From P to T and vertically drawn/ Rigting: Van P na T en vertikaal geteken   | ✓           |

6.4

$$\begin{aligned} \text{charge per sphere/lading per sfeer} &= \frac{Q_1 + Q_2}{2} \checkmark \\ &= \frac{(5 \times 10^{-6}) + (-3 \times 10^{-6})}{2} \checkmark \\ &= 1,0 \times 10^{-6} \text{C} \checkmark \end{aligned}$$

(3)

6.5.1

The electrostatic force experienced per unit positive charge placed at that point. ✓✓ / Die elektrostatiese krag wat per eenheid positiewe lading wat op daardie punt geplaas word, ervaar word

2/0

(2)

6.5.2

$$\begin{aligned} r^2 &= PT^2 + QT^2 \quad \text{OR } r = \sqrt{PT^2 + QT^2} \\ r^2 &= (0,1)^2 + (0,15)^2 \\ &= 0,0325 \text{ m}^2 \checkmark \\ E &= k \frac{Q_1}{r^2} \text{ due to/agv P} \checkmark \\ &= 9,0 \times 10^9 \frac{(1,0 \times 10^{-6})}{0,0325} \checkmark \\ E &= 2,7693 \times 10^5 \text{ N.C}^{-1} \checkmark \end{aligned}$$

(4)

6.5.3

$$\begin{aligned} E &= k \frac{Q_1}{r^2} \text{ due to/agv T} \\ &= 9,0 \times 10^9 \frac{(1,0 \times 10^{-6})}{(0,15)^2} \checkmark \\ E &= 4,0 \times 10^5 \text{ N.C}^{-1} \checkmark \end{aligned}$$

(2)

[20]

**QUESTION 7/VRAAG 7**

7.1 The magnitude of the induced emf across the ends of a conductor is directly proportional to the rate of change in the magnetic flux linkage with the conductor. ✓✓ / Die grootte van die geïnduseerde emk oor die punte van 'n geleier is direk eweredig aan die tempo van verandering in die magnetiese vloedverbinding met die geleier. (2/0) (2)

7.2.1 There will be a reading registered on the galvanometer. ✓ / Daar sal 'n lesing op die galvanometer geregistreer word  
OR/OF  
The galvanometer will deflect to a side. ✓ / Die galvanometer sal na 'n kant afbuig (1)

7.2.2 No reading on the galvanometer/Zero reading ✓ / Geen lesing op die galvanometer/Nul lesing (1)

7.3.1 North pole ✓ / Noordpool (1)

7.3.2 A to/na B ✓✓ (2)

7.3.3 Use the right hand rule (for solenoids). The thumb of the right hand indicates the North pole ✓ and the fingers of the right hand indicate the direction the current flows in the solenoid. ✓ / Gebruik die regterhandreël (vir solenoïdes). Die duim van die regterhand dui die noordpool aan en die vingers van die regterhand dui die rigting aan waarin die stroom in die solenoïde vloei. (2)

**[9]**

**QUESTION 8/VRAAG 8**

8.1 Power is the rate at which work is done. ✓✓/ *Drywing is die tempo waarteen werk verrig word*

**OR/OF**

Power is the rate at which energy is supplied to the device. ✓✓/ *Drywing is die tempo waarteen energie aan die toestel verskaf word*

(2/0) (2)

8.2.1 **OPTION 1/OPSIE 1**

$$R_s = R_A + R_B$$

$$R_s = 4,5 + 4,5$$

$$R_s = 9,0 \Omega \checkmark$$

$$V = IR \checkmark$$

$$V = 2 \times 9,0 \checkmark$$

$$V = 18,0 \text{ V} \checkmark$$

**OPTION 2/OPSIE 2**

$$R_s = R_A + R_B$$

$$R_s = 4,5 + 4,5$$

$$R_s = 9,0 \Omega \checkmark$$

$$V = IR \checkmark$$

$$V = 2 \times 9,0 \checkmark$$

$$V = 18,0 \text{ V} \checkmark$$

(4)

8.2.2 **POSTIVE MARKING FROM 8.2.1/POSITIEWE NASIEN VANAF 8.2.1**

**OPTION 1/OPSIE 1**

$$\left. \begin{aligned} \varepsilon &= V_{ext} + V_{int} \\ \varepsilon &= IR + Ir \end{aligned} \right\} \checkmark \text{ any one/enige 1}$$

$$24 = 18 + 2r \checkmark$$

$$r = 3,0 \Omega \checkmark$$

**OPTION 2/OPSIE 2**

$$\left. \begin{aligned} V_{int} &= \varepsilon - V_{ext} \\ Ir &= \varepsilon - V_{ext} \end{aligned} \right\} \checkmark \text{ any one/enige 1}$$

$$2r = 24 - 18,0 \checkmark$$

$$r = 3,0 \Omega \checkmark$$

**OPTION 3/OPSIE 3**

$$I = \frac{\varepsilon}{R+r} \checkmark$$

$$2 = \frac{24,0}{18,0+r} \checkmark$$

$$r = 3,0 \Omega \checkmark$$

(3)

8.3 Bulbs **A** and **B** are connected in series across the battery, therefore they glow equally brightly, ✓ whereas bulb **C** is connected itself across the battery, then the voltage drop across **C** has the same magnitude as the terminal potential difference, ✓ whereas the same terminal potential difference splits between bulbs **A** and **B** ✓, as a result, bulb **C** glows more brightly than either of bulb **A** and **B**. ✓/

*Gloeilampe A en B is in serie oor die battery gekoppel, daarom gloei hulle ewe helder, terwyl gloeilamp C self oor die battery gekoppel is, dan het die spanningsval oor C dieselfde grootte as die terminaalpotensiaalverskil, terwyl dieselfde terminaalpotensiaalverskil tussen gloeilampe A en B verdeel, gevolglik gloei gloeilamp C helderder as enige van gloeilampe A en B.*

(4)

8.4 DECREASES ✓ / AFNEEM

- External resistance decreases/total resistance decreases ✓
- As emf is constant, total current increases, potential difference in the internal resistance ( $V_{\text{internal}}$ ) increases ✓
- According to the equation;  $V_{\text{ext}} = \epsilon - V_{\text{int}}$ , terminal potential difference across the battery decreases. ✓ /
- *Eksterne weerstand neem af/ totale weerstand neem af*
- *Aangesien emk konstant is, neem die totale stroom toe, die potensiaalverskil in die interne weerstand ( $V_{\text{intern}}$ ) neem toe*
- *Volgens die vergelyking;  $V_{\text{eks}} = \epsilon - V_{\text{int}}$ , neem die terminaalpotensiaalverskil oor die battery af.*

(4)  
[17]

**TOTAL/TOTAAL: 100**

